



NXEXP-6001  
April 3, 2025



## **NXEXP300 EXPANSION UNIT FOR FEED WATER AND DRAFT CONTROL FOR FIREYE PPC6000 / NX6100**

---

### **DESCRIPTION**

The Fireeye NEXUS NXEXP300 is a microprocessor based, expansion module for use with the Fireeye Nexus PPC6000 or NX6100 series of parallel positioning controls. The NXEXP300 expands the capability of the parallel positioning system by adding valuable safety rated digital inputs, sequence draft control, boiler water level control and total dissolved solids (TDS) surface and bottom blow down control.

#### **NXEXP300**

The NXEXP300 expands the capability of the NX6100/PPC6000 with seven low voltage, safety rated, digital inputs along with two line voltage, safety rated digital inputs. When configured via available option parameters, these inputs can be used to simply annunciate conditions, shut the boiler down in the event of a safety related issue, or other user configurable options.

The NXEXP300 includes up to a three-element feed water control scheme to provide ultimate boiler water level control. Drum level, steam flow and feed water flow can be optioned up as needed. Each element requires a 4-20mA, externally powered, signal to the NXEXP300. The feed water pump can be controlled by a VFD or constant speed with modulating feed water value. When the pump is VFD controlled, a minimum speed can be programmed at which point the pump shuts off. If the pump is constant speed, a 4-20mA signal, supplied by either the NXDBVSD (located in the PPC6000/NX6100) or NXDBWLC daughterboard. It is also possible to utilize a CANbus servomotor as the valve actuator. A maximum of two pumps can be controlled by the NXEXP300. Pump alternation based on time or alternate cycles is also available.



Sequence draft control is built into the NXEXP300 to control the boiler outlet damper. When combined with an appropriate differential pressure sensor and actuator, the outlet damper will modulate and maintain the manufacturers' outlet draft set point. The damper can be controlled with a Fireeye CANbus driven servo motor or, a third-party actuator capable of accepting a 4-20mA signal (250-ohm max). The boiler outlet damper is controlled during stand by, pre-purge, ignition and operation to provide a consistent outlet draft for improved combustion performance and reduced stand by losses.

### **NXDBWLC**

The option NXDBWLC expansion daughter board enhances the capability of the Nexus system by optimizing boiler water quality and level. The results are higher quality steam and reduced boiler water side scaling.

The NXDBWLC includes and input for the measurement of Total Dissolved Solids (TDS) which in turn controls a surface, bottom or combination of, blow down valve(s). A fully programmable operating scheme allows each site to be custom configured based on water and operating conditions. Provisions are made for connecting a PT100 RTD temperature sensor or the system can use a built-in steam table for estimating water temperature compensation.

### **SYSTEM REQUIREMENTS:**

- NX6100/PPC6000 Firmware Version 1.305 or higher found at Engineer's Key EK56  
**CONSULT** factory for upgrade options.
- NX6220 or NX6330 12 Key Display.
- NXTSD104 Version 2.115 or higher found on TSD MENU **ABOUT** Key.  
Updates available by download
- At least one 4-20mA transmitter input for water level and/or one 4-20mA transmitter for draft control. This item is supplied by others.
- NXEXP300 Firmware Version 1.106 or higher
- Latest Firmware Version 1.127 replaces Firmware Version 1.118

---

## Safety information

---



### **WARNING**

The equipment described in this manual is capable of causing property damage, severe injury, or death. It is the responsibility of the owner or user to ensure that the equipment described herein is installed, operated and commissioned in compliance with the requirements of all national and local legislation, which may prevail.

When this equipment is fitted to an appliance due regard must also be given to the requirements of that appliance.

**Before attempting to install, commission or operate this equipment all relevant sections of this document must be read and fully understood. If in doubt about any requirements consult Fireye.**

**Installation, commissioning or adjustment of this product MUST be carried out by suitably trained engineers or personnel qualified by training and experience.**

**After installation or modifications to the installation all functions of the equipment MUST be checked to ensure safe and reliable operation of the control.**

The manufacturer of this equipment accepts no liability for any consequences resulting from inappropriate, negligent or incorrect installation, commissioning or adjustment of operating parameters of the equipment. Control panels **must not** be left uncovered while power is on. If it is essential to do so while rectifying faults only personnel qualified by training and experience should be involved.

The time any covers are off must be kept to a minimum and warning notices **must** be posted.

Before attempting any work on this equipment or any equipment controlled by or connected to this equipment, all related electrical supplies **must** be isolated.

Safety interlocks **must not** be removed or over-ridden. Any faults once detected **must** be corrected before the control is operated.

**CAUTION – SOME VERSIONS OF THIS EQUIPMENT CONTAIN A LITHIUM BATTERY  
IN THE DISPLAY UNIT**

### **NOTE**

The manufacturer of this equipment has a policy of continual product improvement and reserves the right to change the specification of the equipment and the contents of this manual without notice.



---

# Table of contents

---

This manual – NXEXP-6001, describes the installation, commissioning, operation and maintenance of the Fireye® NXEXP300 expansion unit for the Fireye® 6000 series controllers.

**Please read the safety information at the front of this manual before proceeding.**

<b>1. DESCRIPTION OF OPERATION .....</b>	<b>8</b>
1.1 NXEXP300 I/O EXPANSION.....	8
1.2 NXDBWLC BOILER WATER CONTROL OPTION.....	8
1.2.1 <i>Reserved</i> .....	8
1.2.2 <i>Water level control</i> .....	8
1.2.3 <i>Modulating feed water PID</i> .....	8
1.2.4 <i>Blow-down control – REQUIRES optional NXDBWLC daughterboard</i> .....	9
<b>2. BOILER WATER CONTROL SENSOR SELECTION.....</b>	<b>10</b>
2.1 BOILER WATER LEVEL SENSORS.....	10
2.2 SET-UP AND CALIBRATION.....	10
2.3 TDS MEASUREMENT SENSOR .....	10
2.4 TDS SAMPLE TEMPERATURE SENSOR.....	10
<b>3. INSTALLATION.....</b>	<b>11</b>
3.1 MECHANICAL FIXING DETAILS FOR THE NXEXP300.....	12
3.2 OPTION LINK SELECTION.....	13
3.2.1 <i>General</i> .....	13
3.2.2 <i>Line supply voltage (LK1 - 4)</i> .....	13
3.2.3 <i>Analog Input 5 (optional)</i> .....	14
3.2.4 <i>Analog Input 6 (optional)</i> .....	14
3.2.5 <i>CANBus Termination Link</i> .....	14
3.3 WIRING.....	15
3.3.1 <i>General</i> .....	17
3.3.2 <i>Earth Connection</i> .....	18
3.3.3 <i>Signal cable Screen Connection</i> .....	19
3.3.4 <i>Terminal Designation</i> .....	20
3.3.5 <i>LIVE and NEUTRAL supply</i> .....	22
3.3.6 <i>High voltage digital inputs and Relay outputs WEx</i> .....	23
3.3.7 <i>Relay Outputs W Dx</i> .....	23
3.3.8 <i>Low Voltage Digital Inputs 1 to 7 WBx</i> .....	23
3.3.9 <i>CANbus and Servo motor Connection</i> .....	24
3.3.10 <i>Interlocking the NXEXP300 to the Fireye NX6100 Burner controller</i> .....	25
3.3.11 <i>Analog, 4-20mA inputs – Externally Powered Wiring</i> .....	26
3.3.12 <i>Analog, 4-20mA inputs – Loop Powered Wiring</i> .....	27
3.3.13 <i>NXDBWLC daughter board (optional)</i> .....	28
3.3.14 <i>Daughter board cable routing</i> .....	29
3.4 FINAL CHECKS.....	29



<b>4. COMMISSIONING THE CONTROLLER</b> .....	<b>30</b>
4.1 GENERAL .....	30
4.2 COMMISSIONING DATA.....	30
4.2.1 Option parameters.....	30
4.3 THE COMMISSIONING PROCESS .....	31
4.4 USING OPTION SET MODE.....	31
4.5 OPTION PARAMETER LIST .....	33
Option 43.0 – * Enable Water level / expansion unit – Set to 3 or 4 ONLY! LV3 .....	33
Option 43.1 – * ** Unit Address of Water level / expansion unit - Set to 10. LV3.....	33
Option 50.2 – NXEXP300 serial communications address (0 - 15) .....	33
Option 50.7 – Modbus device address (0-99) * #DEFAULT : 0.....	34
Option 50.8 – Modbus Communication speed (0-3) .....	34
Option 51.0 – Water Level measurement type (1/4) .....	34
Option 51.1 – Keyboard Auto/Manual enable (0 - 1).....	34
Option 52.0 – Sight Glass Height.....	35
Option 52.1 – Element 1 zero (4 ma) value .....	35
Option 52.2 – Element 1 span (20 ma) value .....	35
Option 52.3 - Element 2 zero (4 ma) value.....	35
Option 52.4 – Element 2 span (20 ma) value.....	35
Option 52.5 thru 52.9 - <i>Reserved</i> .....	35
Option 53.x – Feedwater Drive Serial Number.....	35
Option 53.0 – Feedwater Control Drive .....	36
Option 53.1 – Draft Control Drive.....	36
Option 53.2 – AUX Drive.....	36
Option 54.0 – Modulating feed water mode .....	36
Option 54.1 – Modulating pump minimum output.....	37
Option 55.0 – Modulating Feed-water Drive Direction.....	37
Option 55.1 – Draft Control Drive Direction.....	37
Option 55.2 – AUX Drive Direction .....	37
Option 56.x – <i>Reserved</i> .....	37
Option 57.0 and 57.1 – <i>Reserved</i> .....	37
Option 57.2 – Low water alarm ON point (-99.9 to 99.9).....	38
Option 57.3 – Water (Drum) level set-point (-99.9 to 99.9).....	38
Option 57.4 – Low water alarm OFF point (-99.9 to 99.9) .....	38
Option 57.5 – High water alarm ON point (-99.9 to 99.9). .....	38
Option 57.6 – High High water level limit (-99.9 to 99.9).....	38
Option 57.7 – Pump ON water level when the boiler is off (-99.9 to 99.9) .....	38
Option 57.8 – Pump OFF water level when the boiler is off (-99.9 to 99.9).....	38
Option 58.0 – Second feed pump enable (0 - 1).....	39
Option 58.1 – Pump select input (1 - 16).....	39
Option 58.2 – Pump switch-over time (0-999 hours).....	39
Option 58.3 – Water feed pump 1 trip input (0 to 16) .....	39
Option 58.4 – Water feed pump 2 trip input (0 to 16) .....	39
Option 60.0 – TDS enable (0 - 1) .....	39
Option 60.1 – TDS Calibration value (0 – 9999).....	39
Option 60.2 – TDS Calibration initiate (0 - 1).....	39
Option 60.3 – Boiler water temperature (0 - 360).....	40
Option 60.4 – TDS probe gain (0 - 999).....	40
Option 60.5 – Surface blow-down limit ppm (0 - 999) .....	40
Option 60.6 – Surface blow-down limit ppm (0 - 999) .....	40
Option 60.7 – Read TDS from Blowdown (0 - 1).....	40
Option 60.9 – TDS filter time (1 to 60 minutes).....	40



Option 61.1 – Surface blow-down maximum time interval (0-72 hours) .....	40
Option 61.2 – Surface blow-down minimum time interval (0-60 minutes) .....	41
Option 61.3 – Surface blow-down length (0-360 seconds) .....	41
Option 62.1 - Bottom blow-down maximum time interval (0-99 hours) .....	41
Option 62.2 – Bottom blow-down minimum time interval (0-99 minutes) .....	41
Option 62.3 – Bottom blow-down length (0-99 seconds) .....	41
Option 62.4 – Bottom blow-down HOLD OFF input.....	41
Option 62.8 – Cut in Point.....	41
Option 62.9 – Cut out Point.....	41
Option 63.0 – Feed-water low pressure input. (0 – 13) .....	42
Option 63.1 – Pump off input .....	42
Option 63.2 – Pump off input .....	42
Option 63.3 – Pump off input .....	42
Option 64 – <i>Reserved</i> .....	42
Option 65 – <i>Reserved</i> .....	42
Option 66.3 – High voltage Input 12 Alarm / Lockout Function (0 - 360) .....	42
Option 66.4 – High voltage Input 13 Alarm / Lockout Function (0 - 360) .....	42
Option 66.5 – High voltage Input 12 Fail-safe Alarm / Lockout Display Messages(0 - 999) .....	42
Option 66.6 – High voltage Input 13 Fail-safe Alarm / Lockout Display Messages(0 - 999) .....	42
Option 68.1 to 68.8 – Fail-safe Alarm / Lockout Inputs (0 – 360) - also 66.3 & 66.4.....	42
Option 69.1 to 69.9 – Fail-safe Alarm / Lockout Display Messages* and option parameters 66.5 & 66.6.....	44
Option 70.0 – Water level Proportional band (0 – 999 (99.9”)).....	46
Option 70.1 – Water level Integral time (seconds) .....	46
Option 70.2 – Water level Derivative time (seconds) .....	46
Option 71.0 – Pump ON / Valve Open Input .....	46
Option 71.1 – Pump OFF / Valve Closed Input. ....	46
Option 72.0 to 74.0 – Analog Input Function .....	46
Option 75.0 – Feedwater Flow Input (Element 3).....	47
Option 75.1 – Feedwater Flow Zero (Element 3) .....	47
Option 75.2 – Feedwater Flow Span (Element 3) .....	47
Option 75.3 – Feedwater Flow Maximum .....	47
Option 75.4 – Feedwater Flow PID Proportional Band .....	47
Option 75.5 – Feedwater Flow PID Integral (I) time (seconds) .....	47
Option 75.5 – Feedwater Flow Derivative (D) time (seconds).....	47
Option 76 – <i>Reserved</i> .....	47
Option 77.0 – Steam Flow Input .....	47
Option 77.1 – Steam Flow Zero .....	47
Option 77.2 – Steam Flow Span .....	47
Option 78 – <i>Reserved</i> .....	48
Option 79.0 to 79.9 – Feedwater valve curve. ....	48



Option 80.0 – Draft Pressure Input.....	48
Option 80.1 – Draft pressure zero / span.....	48
Option 80.2 – Draft pressure zero / span.....	48
Option 80.3 – Draft Pressure Setpoint (Burner Firing) .....	49
Option 80.4 – Draft Pressure Proportional Band .....	49
Option 80.5 – Draft Pressure Integral Time.....	49
Option 80.6 – Draft Pressure Derivative Time .....	49
Option 80.7 – Outlet Damper Open Input.....	49
Option 80.8 – Draft High Fire Feed-forward .....	49
Option 80.9 – BurnerlogiX Lockout Input.....	50
Option 81.0 – Draft Pressure Limits Enable .....	50
Option 81.1 – Draft Low Limit .....	50
Option 81.2 – Draft High Limit.....	50
Option 81.8 – Draft Input Filter Time(s) 0 to 15 .....	50
Option 81.9 – Ignition Draft Output (range 0 to 100%) .....	50
Option 82.0 to 82.9 – Draft setpoint profiling .....	51
Option 90.0 to 94.0 – Analog Input Function .....	51
Option 95.0 – Erase Enable (0/1) .....	51
Option 95.1 – Erase Command (0-5).....	51
Option 95.2 – <i>Reserved</i> .....	52
<b>5. FEED-WATER PUMP SPEED CONTROL .....</b>	<b>52</b>
5.1 SYSTEM CONFIGURATION.....	52
<b>6. FAULTS AND FAULT FINDING.....</b>	<b>53</b>
6.1 NXEXP300 EXPANSION MODULE FAULT LISTING .....	53
6.2 NXDBWLC FAULT LISTING.....	55
6.3 THE ENGINEER'S KEY .....	55
6.3.1 <i>Engineer's key parameter list</i> .....	56
6.4 NOTES: .....	60
<b>7. TECHNICAL SPECIFICATION .....</b>	<b>61</b>
7.1 GENERAL .....	61
7.2 DIGITAL (RELAY) OUTPUTS.....	61
7.3 DIGITAL INPUTS.....	62
7.4 ANALOG INPUTS.....	62
7.5 ANALOG OUTPUTS.....	62
7.6 NXDBWLC DAUGHTER BOARD ( <i>OPTIONAL</i> ) .....	63
7.7 CONNECTIONS.....	64
7.8 APPROVALS .....	64
7.9 NXDBWLC DAUGHTER BOARD.....	65
7.10 VARIABLE SPEED DRIVE (VSD) DAUGHTER BOARD P/N NXDBVSD.....	66
<b>8. NXEXP300 TERMINAL LAYOUT .....</b>	<b>67</b>



---

# 1. Description of operation

---

## 1.1 NXEXP300 I/O expansion.

The NXEXP300 Expansion Module provides additional fail-safe digital input channels to enhance the input capabilities of the NX6100 or PPC6000 control systems. The characteristics of the input channels are programmed by option parameter in a similar way to those in the NX6100/PPC6000 controller(s). The status of the inputs is reported to the burner controller via CANbus. In addition, the analog inputs and digital (relay) outputs may be configured for other non-critical use, using block programming via the Abacus programming tool.

## 1.2 NXDBWLC Boiler Water control option.

Option parameters in the NX6100/PPC6000 are set to enable boiler water level control. The NXEXP300 may have an optional daughter board fitted within the main enclosure, which will measure Total Dissolved Solids (TDS) in the boiler water. The controller may be programmed to perform 'blow-down' functions based on schedules or water quality measurement

### 1.2.1 *Reserved*

### 1.2.2 Water level control.

The NXEXP300 supports both ON/OFF and modulating water level control.

ON/OFF control energizes a feed water pump output relay at a programmed Pump ON level (opt 57.2) and de-energizes the output at a Pump OFF level (opt 57.4).

Modulating water level control may use one of two strategies for the controlling element, as follows:

A constant speed pump with flow controlled by a modulating feed valve,

**Or**

Feed water flow controlled by a variable speed feed water pump.

For both methods, the nominal water level is programmed as a set-point (opt 57.3)

### 1.2.3 Modulating feed water PID

The responsiveness of the modulating feed water control is set using options 70.0, 70.1, and 70.2. Each system will respond differently. Therefore, the site operators / instrument technicians must be comfortable with adjusting the PID to suit operational conditions.



#### **1.2.4 Blow-down control – REQUIRES optional NXDBWLC daughterboard**

Blow-down to control TDS may be based upon a simple time interval or measured TDS. Timed blow-down may be scheduled for water surface and boiler bottom. A time period for each blow-down period is set by option parameter. The interval between each period is set by option parameter as the Minimum time period.

Surface and bottom blow-down functions may be configured to start when a measured TDS limit is reached. TDS limits for both surface and bottom blow-down are set by option parameter. In this case a Maximum time interval may be programmed to instigate a blow-down cycle regardless of the measured TDS to ensure regular blow-down of the boiler. If the TDS limit or Maximum time interval is reached, then the Maximum timer will be reset and restarted. The Minimum timer over-rides the TDS limit and Maximum timer to ensure that blow-down cycles are not too frequent.



---

## 2. Boiler Water Control Sensor Selection

---

### 2.1 Boiler Water level sensors.

The NXEXP300 has terminals dedicated to boiler water level sensors with a 4-20mA output of the measured level. The use of differential pressure or other sensors to meet the requirements below.

1. Suitable for connection to pressure vessels operating up to the maximum boiler pressure
2. Suitable for operation at high temperature – see boiler specification
3. Configured for easy field calibration
4. 2 wire, 4-20mA, connection

### 2.2 Set-up and calibration.

Level sensors must measure the water level in the boiler either directly into the boiler shell (Drum) or in a secondary chamber connected to the boiler. Sensors will require calibration such that their output is representative of the boiler water operating range.

Externally powered sensors must be selected for operating range and then calibrated such that the 4mA and 20mA levels are correct for the operating range. Typically, the 12mA level will be set for the normal operating level and then the 4mA levels set below the Lower low level. The 20mA level will be set above the High High level. All levels must be within the range of the sight-glass gauge.

### 2.3 TDS measurement sensor

The NXDBWLC daughterboard has terminals dedicated to the measurement of TDS either as a 2-wire or 4-wire measurement. Users should select a TDS measurement probe based upon the measurement point on the boiler system. Factors to be considered are water pressure and temperature at the measurement point.

### 2.4 TDS sample temperature sensor

In order to determine the TDS levels within a water sample the temperature of the sample must be known. The NXDBWLC daughterboard has terminals dedicated for water sample temperature measurement. These are for direct connection of a RTD (PT100) type probe with either 2 or 4 wire connection.

---

## 3. Installation.

---

This section contains basic installation information concerning choice of controller and servo-motor environment, wiring specification and connection details.



### **WARNING**

**EXPLOSION OR FIRE HAZARD CAN CAUSE PROPERTY DAMAGE, SEVERE INJURY OR DEATH**

**To prevent possible hazardous burner operation, verification of safety requirements must be performed each time a control is installed on a burner, or the installation modified in any way.**

**This control MUST NOT be directly connected to any part of a SELV circuit.**

#### WHEN INSTALLING THIS PRODUCT:

- Read these instructions carefully and ensure you fully understand the product requirements. Failure to follow them could damage the product or cause a hazardous condition.
- Check the ratings given in these instructions to ensure the product is suitable for your application.
- After installation is complete, check the product operation is as described in these instructions.



### **CAUTION**

- Disconnect the power supply before beginning installation to prevent electrical shock, equipment and/or control damage. More than one power supply disconnect may be involved.
- Wiring must comply with all applicable codes, ordinances and regulations.
- Loads connected to the NXEXP300 controller must not exceed those listed in the specifications as given in this manual.
- All external components connected to the control must be approved for the specific purpose for which they are used.
- Servo motors must be selected to ensure they operate within their specification.
- Ensure all sections of the controller are earthed, to maintain electrical safety.



### 3.1 Mechanical fixing details for the NXEXP300.

The expansion unit has been designed for fitting inside a burner control cabinet. The cabinet should have a minimum protection level of IP40 for indoor use or IP54 for outdoor use.

The expansion unit can be mounted in any attitude, clearances of a least 2.36" (60mm) should be left around the unit to allow sufficient space for wiring and to ensure reliable operation.

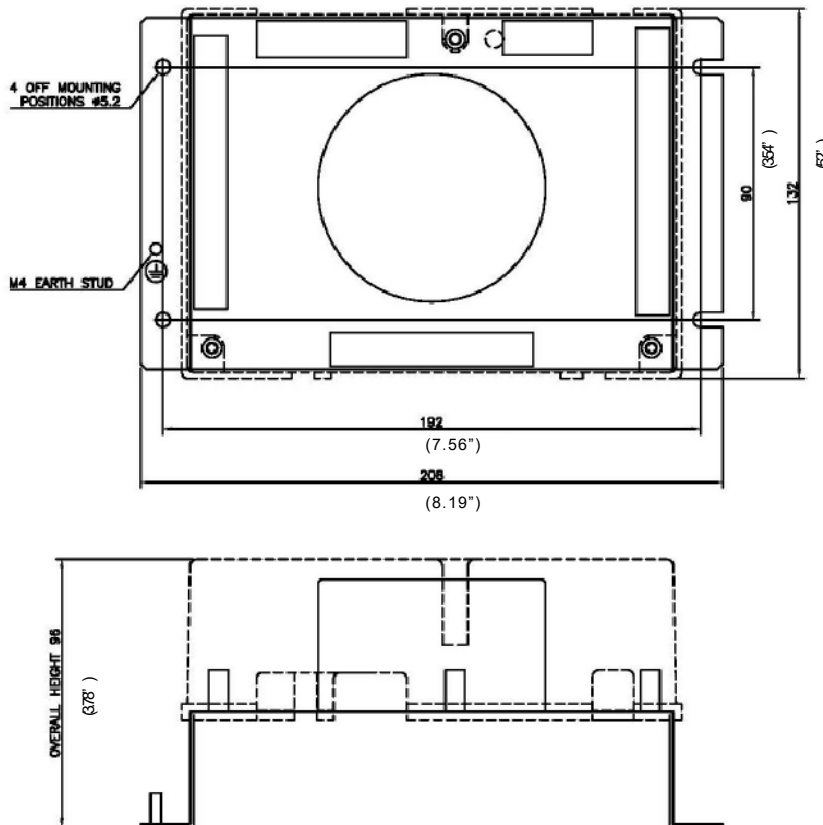

The expansion unit must be installed in a clean environment, according to EN6730-1, and the ambient operating temperature range of the equipment is 32-140°F (0 to 60°C). Refer to section 7 for more details.

Allow 3.9" (100mm) for the depth of the controller including the lid, and LED window. Provide additional clearance as required.

The expansion unit **MUST** be earthed to maintain electrical safety and ensure reliable operation.

## 3.2 Option link selection.

### 3.2.1 General

The NXEXP300 controller has a number of option selection links, located on the main circuit board. These option links will not be accessible once the controller is mounted in the burner cabinet. The function and settings of the links are given below and are marked on the board alongside each link. These links must be set to the correct position before power is applied to the controller. A picture of the circuit board layout showing the fuse and jumper locations is below.

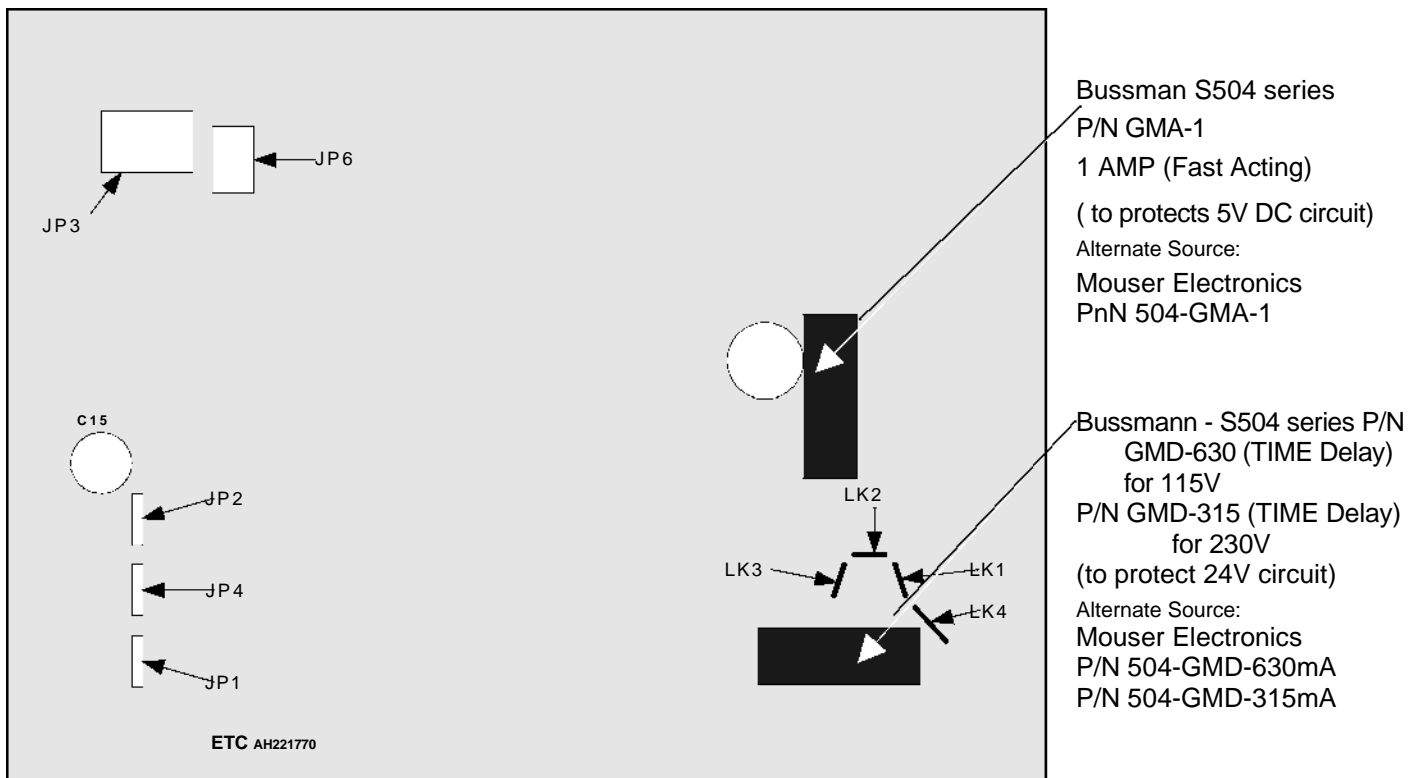

### 3.2.2 Line supply voltage (LK1 - 4)

**WARNING** Incorrect setting of the Links **WILL** damage or destroy the unit.

The possible supply voltages are shown below, together with the necessary fuse rating. Incorrect setting of the "supply selection links" will cause damage to the controller.

The correct fuse (type and rating) must be fitted, failure to do so may result in damage to the controller.

Supply voltage(V)	Links required	Fuse rating(mA)
120	LK1 and LK3	630 anti-surge
230	LK2 and LK4	315 anti-surge

### 3.2.3 Analog Input 5 (optional)

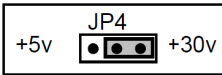

- For a 4-20mA loop-power sensor, choose a +30V supply.

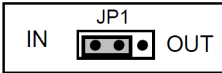

- For a 4-20mA loop-power sensor, choose current (IN) input.

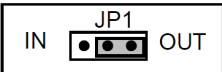

- For externally powered signal, choose OUT position

### 3.2.4 Analog Input 6 (optional)

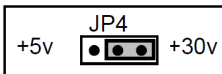

- For a 4-20mA loop-power sensor, choose a +30V supply.

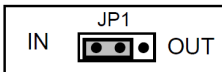

- For a 4-20mA loop-power sensor, choose current (IN) input.

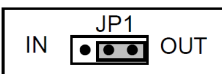

- For externally powered signal, choose OUT position

### 3.2.5 CANBus Termination Link.

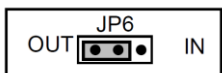

- JP6 is used to select a CANBus termination resistor in or out of circuit. In most, if not all, applications this link should be set to the OUT position on the NXEXP300 **ONLY**.
- This jumper exists on the PPC6000/NX6100 and should be left in the IN position, unless specifically stated. **CONSULT FACTORY.**



## 3.3 Wiring

### 3.3.1 General

## READ THIS FIRST!!!!

There are numerous mentions of “...overall braided shielded (screened) wire” throughout this manual. This is an important aspect to reliable operation.

**Table 3.3.1-A lists the only approved wire** for this control. While one of the specifications relating to shielded wire indicates the amount of coverage (0-100%), this is not the only factor in selecting wire. While it is true, “foil and drain” shielded wire specifications indicate 100% coverage as compared to approximately 85% for braided type, the cross-sectional area of the braid provides the required noise immunity. Also, the special grounding clamp bars on this control do not provide adequate connection to foil shield. In fact, most foil shields do not conduct on the surface.

**Using the “drain” wire to a ground stud does not properly protect the control.**



## CAUTION

- Disconnect the power supply before beginning installation to prevent electrical shock, equipment and/or control damage. More than one power supply disconnect may be involved.
- Wiring must comply with all applicable codes, ordinances and regulations.
- Loads connected to the PPC6000 series, optional daughter board and optional oxygen probe interface must not exceed those listed in the specifications as given in this manual.
- Ensure the maximum total load on the CANbus cabling (servomotors, display etc.) is within the specifications of the main unit and for the cable being used.
- This control **MUST NOT** be directly connected to any part of a Safety Extra Low Voltage (SELV) circuit.

**WIRING INSTALLATION MUST BE CARRIED OUT BY A COMPETENT ELECTRICIAN AND IS SUBJECT TO I.E.E. WIRING REGULATIONS (BS 7671:1992), NEC AND/OR LOCAL STANDARDS, WHICH MAY PREVAIL.**

**HAZARDOUS VOLTAGES MUST BE ISOLATED BEFORE SERVICE WORK IS CARRIED OUT.**

The NXEXP300 unit **MUST** be mounted within a ‘burner cabinet’ or similar and **MUST** be grounded (earthed) to the overall enclosure to ensure safe and reliable operation.

Do not use a green or green/yellow conductor for any purpose other than ground (earth). The metal body of all component parts **MUST** be connected to ground (earth) using a green or green/yellow conductor.



The screen of the signal cable **MUST** not be used to provide the safety ground (earth), a separate connection using the largest cross-sectional area green or green/yellow ground (earth) wire possible **MUST** be made.

The screen termination clamps on the control are only provided to allow connection of the cable screens to the main unit they do not provide strain relief. The signal cable screens **MUST** be connected at the screen termination clamps only, unless stated otherwise. **Screened cables MUST be of the 'copper braid shield' type** and not 'foil with drain wire', the cross section of the drain wire is insufficient to provide correct screening of the signals and there is also no provision to connect the foil or drain at the main unit.

Secure all cables carried in conduit at both ends using a suitable anchorage method in the cabinet.

All cabling that is required to operate at above 50v must be multi-strand single conductor (core), PVC insulated, 16 AWG (19/0.3mm) and should meet the requirements of I.E.C. 227 or I.E.C. 225, NEC

To comply with EMC requirements, wire the control and any optional units using the specified cable sizes and screen connections observing any maximum cable length limitations. **The manufacturer of this equipment recommends the use of bootlace ferules on all wire ends, as a "best practice"**.

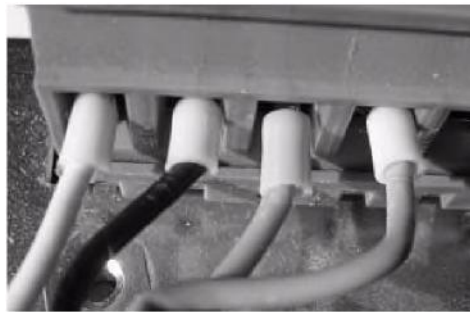

Bootlace  
Ferules

The equipment described in this manual has been tested for compliance to the CE and UL directives listed in the section headed 'approvals'. However, once connected to a burner and other associated controls it is the responsibility of the installer to ensure the complete installation meets the requirements of the UL or CE directives relevant to the particular installation.

### **IMPORTANT: Wiring Guidelines**

All wiring to this control must comply with National, State and Local electrical codes. In general, all insulation must meet or exceed the highest voltage present on any conductor in a conduit, raceway or panel, e.g. 480-volt motor wiring would require at least 600-volt insulation. Consult the National Electric code for guidance.



**IMPORTANT: Low Voltage (vertical terminal strips)**

All low voltage circuits and communication wire must be fully shielded braided (screened) type wire of the specified gauge and number of conductors.

**Table 3.3.1-A provides the only approved wire for this application. No “or equal” is provided. Use of wire not approved by Fireeye may VOID warranty.**

All wiring to terminal block “WA” & “WB” as well as to any optional daughter board (e.g. VFD) and the Power/CANbus wiring to the display, must be fully shielded braided (screened) wire per **Table 3.3.1-A**.

Alpha (conductors)		Carol (conductors)		Belden (conductors)		Harting (conductors)
4	2	4	2	4	2	
25164	25162	C2688	---	994	---	N/A
25524	25522	---	---	7895A*	---	094560001020200

\* **NOTE:** If Belden 7895A wire is used it will be necessary to use 2 conduit adapters per device if wired as a “daisy chain.” See **Table 3.3.1-D**

**Table 3.3.1-A**

**IMPORTANT: Line Voltage (horizontal terminal bottom (WE) and top left (WD) – do not require shielded wire.**

All line voltage wiring must be no greater than 16 AWG (19/0.3mm) THHN, TFFN or equal.

The following table provides a guide for converting from NEMA Enclosure Type Numbers of IEC Enclosure Classification Designations. The NEMA Types meet or exceed the test requirements for the associated IEC Classifications; for this reason, the table should not be used to convert from IEC classifications to NEMA Types and the NEMA to IEC conversion should be verified by test.

NEMA Enclosure Type Number	IEC Enclosure Designation
1	IP10/IP40/IP20
2	IP11
3	IP54
300V 3R	IP14
600V 3S	IP54
4 and 4X	IP56
5	IP52
6 and 6P	IP67
12 and 12K	IP52
13	IP54



**Table 3.3.1-B**

**International Wire Size Conversion Table:** All dimensions shown are as accurate as possible, however, when converting AWG, SWG, inches and metric dimensions, round-off errors do occur. Wire and cable also vary depending upon manufacturer.

American or Brown & Sharpe's AWG	British Standard SWG	Nominal Conductor Diameter (Ø) (inches)	Fractional Equivalent (inches)	Nominal Conductor Diameter (Ø) (mm)	Cross Sectional Conductor Area Sq mm (mm <sup>2</sup> )	** Stranded Wire Number of x Diameter (inches)	Construction Strands of Strands (mm)
16	-	0.051	-	1.30	1.33	26 x .010	19 x .30
18	19	0.040	-	1.02	0.82	16 x .010	7 x .4
20	21	0.032	-	0.81	0.52	10 x .010	16 x .2
24	25	0.020	-	0.51	0.20	7 x .008	7 x .2

**Table 3.3.1-C**

<b>CONDUIT CONNECTOR ADAPTERS</b> Metric to 1/2-inch NPSL Female	
<b>Device</b>	<b>Fireye Part Number</b>
NXC04 Servomotor	35-321
NXC12 Servomotor	35-321
NXC20, NXC20A Servomotor	35-322
NXC40 Servomotor	32-372
NXIATS Inlet Air Sensor	35-336
NX1020-1,-2 Gas Pressure Sensor	35-371
NX1030+1,-2 and NX1034-1,-2 Steam Pressure Sensor	35-371
NX1040-1 and NX1044-1 Boiler Temperature Sensor	36-336
NXO2INT Oxygen Interface	35-372
All O <sub>2</sub> Probe Assembly	35-372

**Table 3.3.1-D**

### 3.3.2 Earth Connection

The main controller **MUST** be connected to earth. The connection to the controller should be made at the 'stud' showing the Earth symbol. This connection is required to maintain the overall electrical safety of the installation and ensure the EMC performance of the equipment. Failure to comply with this wiring requirement will affect the performance of the system and may cause a hazardous condition to occur. Ensure that a good electrical connection is made between both the controller, and the burner panel then between the burner panel and earth. Where necessary, scrape any paint away from connection points and use shake-proof washers to ensure a reliable electrical connection. Always use the largest cross-sectional area earth wire possible.

### 3.3.3 Signal cable Screen Connection.

**Signal cables MUST have a screen of the ‘tinned copper braid shield’ type. The manufacturers of this equipment recommend Belden type 9940 or 3084A or Alpha type 3233 or 6352.**

These types of cable may also employ a ‘foil with drain wire’. This is not suitable as a screen because the cross section of the drain wire is insufficient to provide correct screening of the signals and there is also no provision to connect the foil or drain at the main controller. Signal cable screens MUST be connected at the screen termination clamps only, unless stated otherwise in this manual. The screen termination clamps on the controller are only provided to allow connection of the cable screens to the main controller - they do not provide strain relief.

Screen termination clamps are provided on the main controller for termination of cable screens (tinned copper braid type). If the controller is used with a daughter board the screens of these cables MUST also be terminated to the cable clamps. It is important to ensure that the screen and associated insulation cover the cable cores as close as possible to the terminals to which they are connected and **not** cut-back to where the cable passes through the screen termination clamp.

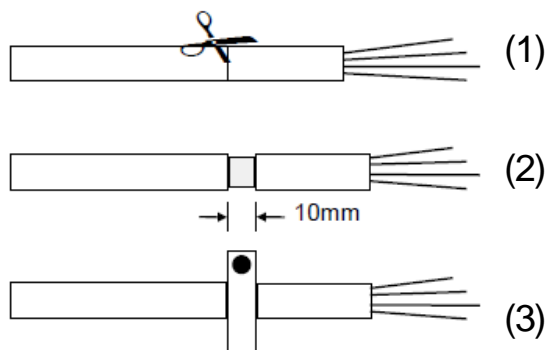

The cable should be prepared by cutting around the outer insulation, taking care not to damage the screen (1).

Pull the insulation apart to expose 10mm of the screen braid (2).

Place the exposed length of screen braid between the conductive strips attached to the cable ‘clamps’, ensure a ‘good’ connection between the screen and the ‘clamp’ is achieved (3 and photograph). The ‘clamps’ are not intended to provide strain relief for the cables.



Where screened cables are required to run through one device to connect to another, terminals are provided to allow the screens to be connected, by forming a 'tail' with the braided screen of each cable, the length of unscreened cable short be kept as short as possible, but in any case, **MUST NOT exceed 30mm**, per cable 'tail'.

Where screened cables are required to connect to a terminal rail, screens **MUST NOT** be connected to Earth at the terminal rail but must pass to the screens of onward connecting cables in insulated terminals. Screen 'tails' and each cable core **MUST not exceed 30mm**, per cable 'tail'.

### 3.3.4 Terminal Designation

All terminals within the system have 'unique' terminal designations to reduce the possibility of wiring errors. This information is tabulated below:

Terminal Number	Location	Function	Voltage Range
WA1	Expansion Unit	24Vac Supply for Servos, Display etc.	24 – 40Vac
WA2	Expansion Unit	24Vac Supply for Servos, Display etc.	24 – 40Vac
WA3	Expansion Unit	CAN +	0 – 5V
WA4	Expansion Unit	CAN -	0 – 5V
WA5	Expansion Unit	Reserved	5Vdc +
WA6	Expansion Unit	Reserved	0 – 5Vdc -
WA7	Expansion Unit	Water level input 1 (4-20mA) AI 1	0 – 5Vdc
WA8	Expansion Unit	Water level input 2 (4-20mA) AI 2	0 – 5Vdc
WA9	Expansion Unit	Water level input 3 (4-20mA) AI 3	0 – 5Vdc
WA10	Expansion Unit	Reserved	0 – 30Vdc
WA11	Expansion Unit	0Vdc for 4-20mA input signals AI 4	0Vdc
WA12	Expansion Unit	4-20mA I/p – AI 4 - Reserved	0 – 5Vdc
WA13	Expansion Unit	30Vdc sensor supply	0Vdc
WA14	Expansion Unit	0Vdc for input signals Reserved	0Vdc
WA15	Expansion Unit	4-20mA I/p– AI5	0 – 5Vdc
WA16	Expansion Unit	Sensor Supply +	30Vdc



Terminal Number	Location	Function	Voltage Range
WA17	Expansion Unit	Reserved	0 – 5Vdc
WA18	Expansion Unit	0Vdc for 4-20mA input signals AI5 & 6	0Vdc
WA19	Expansion Unit	4-20mA I/p – AI6	0 – 5Vdc
WA20	Expansion Unit	5/30Vdc sensor supply	30Vdc
WB1	Expansion Unit	24Vac Supply for Servos, Display etc.	24 – 40Vac
WB2	Expansion Unit	24Vac Supply for Servos, Display etc.	24 – 40Vac
WB3	Expansion Unit	CAN +	0 – 5V
WB4	Expansion Unit	CAN -	0 – 5V
WB5	Expansion Unit	Digital input 7&8 Common, Low voltage	0 – 5V
WB6	Expansion Unit	Digital input 7, Low voltage	0 – 5V
WB7	Expansion Unit	Digital input 8, Low voltage	0 – 5V
WB8	Expansion Unit	Reserved	0 – 5V
WB9	Expansion Unit	Digital input 1–4 Common, Low voltage	0 – 5V
WB10	Expansion Unit	Digital input 1, Low voltage	0 – 5V
WB11	Expansion Unit	Digital input 2, Low voltage	0 – 5V
WB12	Expansion Unit	Digital input 3, Low voltage	0 – 5V
WB13	Expansion Unit	Digital input 4, Low voltage	0 – 5V
WB14	Expansion Unit	Digital input 5–7 Common, Low voltage	0 – 5V
WB15	Expansion Unit	Digital input 5, Low voltage	0 – 5V
WB16	Expansion Unit	Digital input 6, Low voltage	0 – 5V
WB17	Expansion Unit	Digital input 7, Low voltage	0 – 5V
WB18	Expansion Unit	Reserved	0 – 5V
PB19	Expansion Unit	Reserved	0 – 5V
WC1	Expansion Unit	Modbus 0 volt	0 – 5V
WC2	Expansion Unit	Modbus B (-)	0 – 5V
WC3	Expansion Unit	Modbus A (+)	0 – 5V
WC4	Expansion Unit	RS485 0 volt - Comfire	0 – 5V
WC5	Expansion Unit	RS485 B (-) - Comfire	0 – 5V
WC6	Expansion Unit	RS485 A (+) - Comfire	0 – 5V
WD1	Expansion Unit	Relay output Supply (120/230V)	0 – 230V
WD2	Expansion Unit	Feedwater pump 1 output	0 – 230V
WD3	Expansion Unit	Feedwater pump 2 output	0 – 230V
WD4	Expansion Unit	Low water Alarm	0 – 230V
WD5	Expansion Unit	High water Alarm	0 – 230V
WE1	Expansion Unit	Controller Supply (live)	115 - 230Vac
WE2	Expansion Unit	Controller Supply (neutral)	115 - 230Vac
WE3	Expansion Unit	Alarm output	0 – 230Vac
WE4	Expansion Unit	Digital input 12, Line voltage	0 – 230Vac
WE5	Expansion Unit	Digital input 13, Line voltage	0 – 230Vac
WE6	Expansion Unit	Relay output Common (IN)	0 – 230Vac
WE7	Expansion Unit	Expansion Unit healthy output (OUT)	0 – 230Vac
WE8	Expansion Unit	Surface Blowdown Relay output (6)	0 – 230Vac
WE9	Expansion Unit	Bottom Blowdown Relay output (5)	0 – 230Vac
WE10	Expansion Unit	Reserved Relay output	0 – 230Vac



Terminal Number	Location	Function	Voltage Range
PK1	Servomotor	24Vac Supply	24 – 40Vac
PK2	Servomotor	24Vac Supply	24 – 40Vac
PK3	Servomotor	CAN +	0 – 5V
PK4	Servomotor	CAN-	0 – 5V
PK5	Servomotor	Screen connection	Not applicable
PK6	Servomotor	Screen connection	Not applicable
WZ1	Daughter Board	TDS probe +	0 – 5Vdc
WZ2	Daughter Board	TDS + sense	0 – 5Vdc
WZ3	Daughter Board	TDS – sense	0 – 5Vdc
WZ4	Daughter Board	TDS probe -	0 – 5Vdc
WZ5	Daughter Board	PT100 +	0 – 5Vdc
WZ6	Daughter Board	PT100 + sense	0 – 5Vdc
WZ7	Daughter Board	PT100 - sense	0 – 5Vdc
WZ8	Daughter Board	PT100 -	0 – 5Vdc
WZ9	Daughter Board	Relay o/p	0 – 40V
WZ10	Daughter Board	Relay Common	0 – 40V
WZ11	Daughter Board	Reserved	24V dc
WZ12	Daughter Board	Reserved	0 – 5Vdc
WZ13	Daughter Board	Reserved	0 – 5Vdc
WZ14	Daughter Board	Reserved	24Vdc
WZ15	Daughter Board	Reserved	0 – 5Vdc
WZ16	Daughter Board	Reserved	0 – 5Vdc
WZ17	Daughter Board	Isolated 4-20mA output + (250-ohm max)	0 – 12Vdc
WZ18	Daughter Board	Isolated 4-20mA output 0V (250-ohm max)	0 – 12Vdc

NOTE: Maximum input impedance is 250 Ohms.

### 3.3.5 LIVE and NEUTRAL supply.



## WARNING

Incorrect setting of the Supply Voltage Links **WILL** damage or destroy the unit.

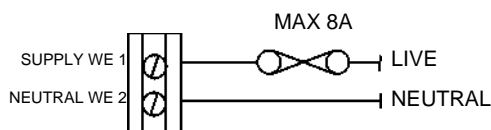

The LIVE and NEUTRAL supplies must be connected using multi-strand single core PVC insulated 16/0.2mm wire. The live connection should be fused with a **maximum rating** as shown. **If a fuse greater than 4A is fitted, each relay (pump, fan and vent) output supplied via this terminal MUST be separately fused at 4A maximum, to protect the relay contacts from ‘welding’.**

### 3.3.6 High voltage digital inputs and Relay outputs WEx

Alarm output WE3 Digital i/p	⓪
12 WE4 Digital i/p 13 WE5	⓪
Line Supply WE6 Controller	⓪
OK o/p WE7 Surface	⓪
Blowdown Relay output (6)	⓪
WE8 Bottom Blowdown	⓪
Relay output (5) WE9	⓪
Reserved WE10	⓪

**Fuses not exceeding 4A must protect all relay outputs. Fit a 4A fuse to the Burner Panel Supply or controller supply/burner select input or, where the total current exceeds 4A, fit an 8A fuse to protect the controller and separate fuses on each relay output.**

These outputs must be connected using multi-strand single core PVC insulated 16/0.2mm wire. In most cases, the outputs can be connected directly to the designated devices without the use of external relays.

### 3.3.7 Relay Outputs WDX

High Water Alarm WD 5 Low	⓪
Water Alarm WD 4 Feed	⓪
Water Pump 2 o/p WD 3 Feed	⓪
Water Pump 1 o/p WD 2	⓪
RELAY COMMON WD 1	⓪

**Fuses not exceeding 4A must protect all relay outputs. If a control panel fuse greater than 4A is fitted the relay common MUST be separately fused at 4A or where the total current exceeds 4A, a 4A fuse on each relay output MUST be fitted to protect the relays from 'welding'.**

These outputs must be connected using multi-strand single core PVC insulated 16/0.2mm wire. As this cable may lay adjacent to, and/or in the same conduit as high voltage wiring, the cable voltage rating must exceed the maximum voltage carried by any other cable connected to the controller or run in the same conduit.

### 3.3.8 Low Voltage Digital Inputs 1 to 7 WBx

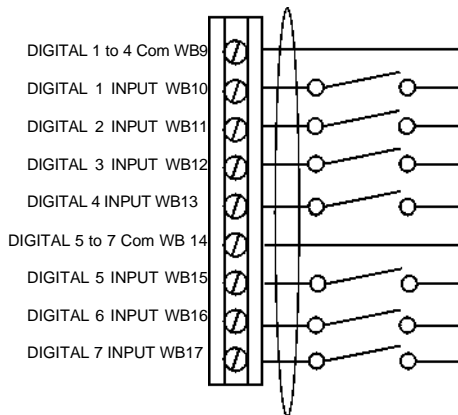

These Low Voltage digital inputs can be used for safety related functions and their function is programmed by option parameters 68.1 to 68.7 inclusive.

These inputs MUST be connected using multi-strand overall 'braid' screened, PVC insulated, 2-core, 7/0.2mm wire. As this cable may lay adjacent to, and/or in the same conduit as Line voltage wiring, the cable voltage rating must exceed the maximum voltage carried by any other cable connected to the controller or run in the same conduit.

To Clamp Bar

**Note: These inputs expect dynamic, (0/5V) signals and must be powered from the terminals provided. Under no circumstances must these inputs or outputs be connected to Line potential. Connection of any voltage above 5V to these terminals will damage or destroy the controller.**

### 3.3.9 CANbus and Servo motor Connection



## CAUTION

- The total electrical load for all servo motors connected to the control **MUST NOT** exceed 60VA.
- Incorrect connection may damage or destroy the units being connected.

There are 2 sets of terminals available for the CANbus connection, both sets are identical.

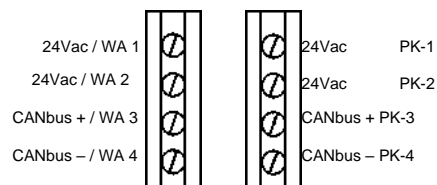

CANbus allows several options for connecting the devices together, based on the physical position of each device relative to the main controller and the current required by each device. The recommended cable is overall 'braid' screened, PVC insulated, 4-core, 7/0.2mm wire, which has a maximum current carrying capability at 60°C (140°F) of 600mA. This will limit the maximum number of devices which may be connected via a single 'bus'. As this cable

may lay adjacent to, and/or in the same conduit as Line voltage wiring, the cable voltage rating must exceed the maximum voltage carried by any other cable connected to the controller or run in the same conduit.

Where the maximum current required on the cable exceeds 600mA (for example when using 40Nm servo motors which are rated at 18VA), 4-core, 16/0.2mm, cable must be substituted. Use of 2 overall screened cables, one for the CAN and one for the power, is not recommended since this would increase the number of 'screens' to be connected in each device for which there is no provision.

Connect the screen with the use of the screen termination clamp, at the main controller.



### 3.3.10 Interlocking the NXEXP300 to the Fireye NX6100 Burner controller.

To ensure fail-safe integrity of the expansion module it must be electrically and digitally connected to the NX6100 or PPC6000 burner controller in the following manner:

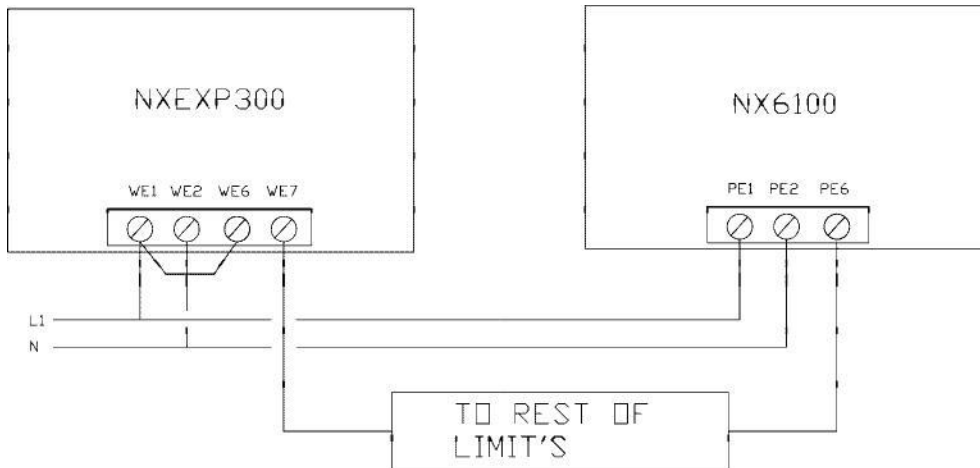

NX6100 ONLY

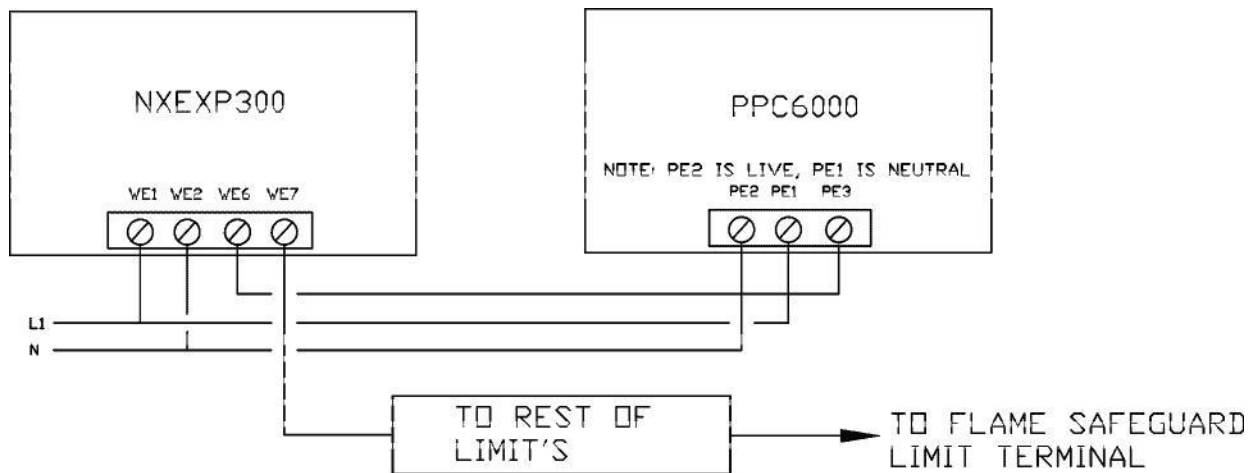

PPC6000 ONLY

Failure to follow these wiring schemes will result in permanent lockout once option parameters are set.

### 3.3.11 Analog, 4-20mA inputs – Externally Powered Wiring



## CAUTION

Incorrect connection or application of excess voltage to sensors may damage or destroy the sensor or controller inputs.

**Note:** All sensors must have isolated outputs.

### EXTERNALLY POWERED WIRING

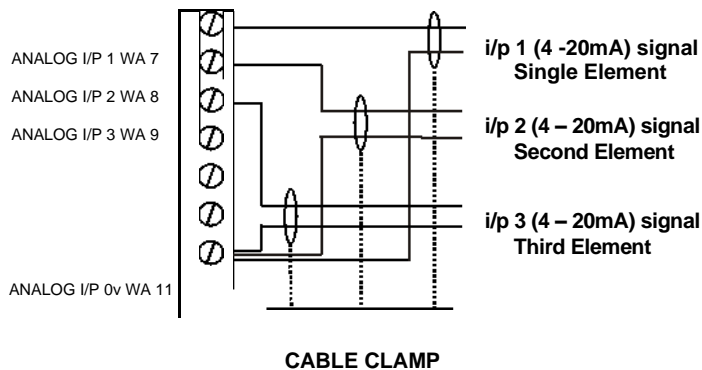

The pressure sensor cabling **MUST** be overall 'braid' screened PVC insulated 7/0.2mm (number of cores as required by the relevant sensor). As this cable may lay adjacent to, and/or in the same conduit as Line voltage wiring, the cable voltage rating must exceed the maximum voltage carried by any other cable connected to the controller or run in the same conduit.

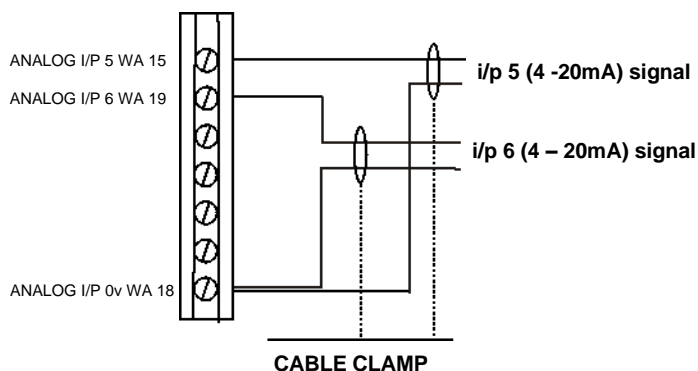
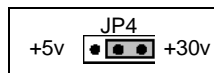
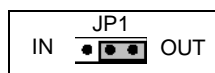

Connect the cable 'braid' screen to the controller with the use of the screen termination clamp. Make all connections at the sensor/transmitter first.

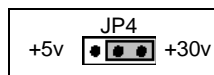
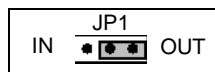

### 3.3.12 Analog, 4-20mA inputs – Loop Powered Wiring



## CAUTION

Incorrect connection or application of excess voltage to sensors may damage or destroy the sensor or controller inputs.

**Note:** All sensors must have isolated outputs.

### LOOP POWERED WIRING

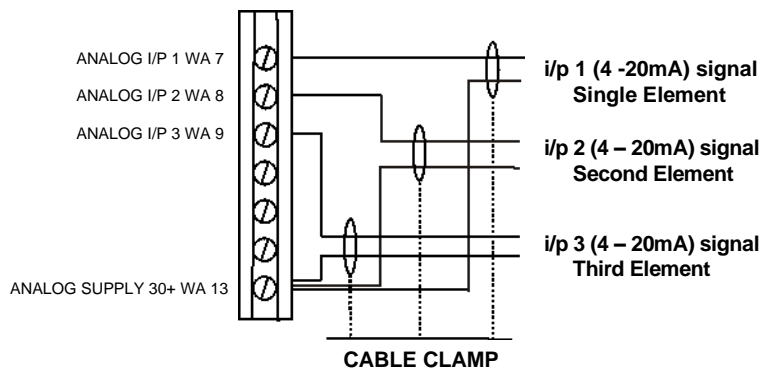

The pressure sensor cabling MUST be overall 'braid' screened PVC insulated 7/0.2mm (number of cores as required by the relevant sensor). As this cable may lay adjacent to, and/or in the same conduit as Line voltage wiring, the cable voltage rating must exceed the maximum voltage carried by any other cable connected to the controller or run in the same conduit.

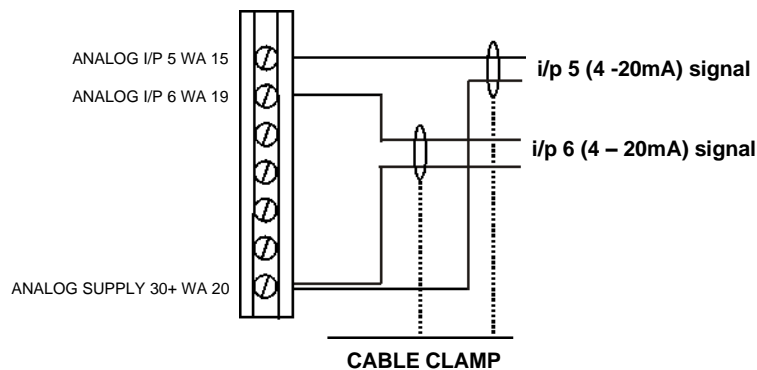
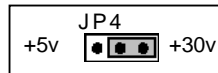
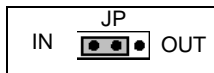

Connect the cable 'braid' screen to the controller with the use of the screen termination clamp. Make all connections at the sensor/transmitter first.

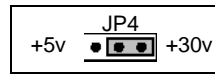
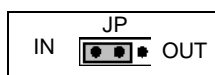

### 3.3.13 NXDBWLC daughter board (optional).

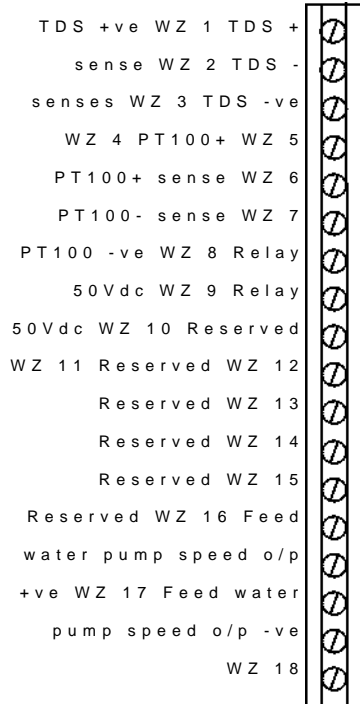

The cabling for all of these terminals MUST be overall 'braid' screened, PVC insulated, 7/0.2mm,2-core. As this cable may lay adjacent to, and/or in the same conduit as Line voltage wiring, the cable voltage rating must exceed the maximum voltage carried by any other cable connected to the controller or run in the same conduit.

The function of the relay can be set by option parameter. **Note:** the maximum rating of the relay is 100mA at 50Vdc.

**Incorrect connection or application of excess voltage may damage or destroy the devices being connected.**

Best wiring scheme for 2 terminal TDS probe.

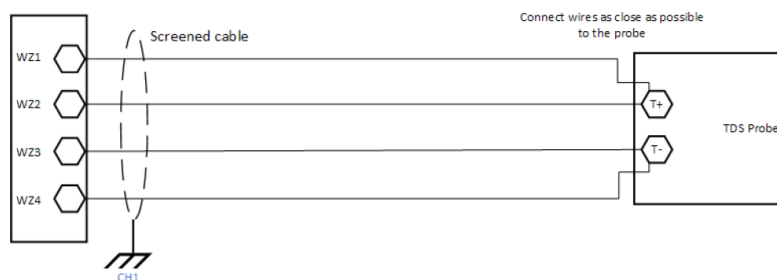

Acceptable wiring scheme for 2 terminal TDS probe.

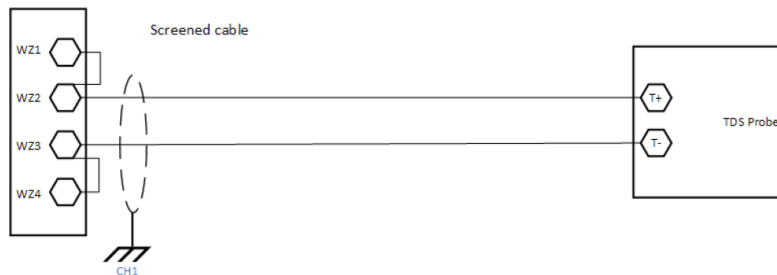

### 3.3.14 Daughter board cable routing



Route the screened signal cables through the clamps, exposing the braid in the clamp, before terminating at connectors.

Keep the wire tails as short as possible to ensure maximum screen protection after the screen clamp, as shown in the picture on the left.

## 3.4 Final checks



### **WARNING**

Incorrect setting of the Supply Voltage Links **WILL** damage or destroy the controller.

Before applying power, make the following checks:

- The controller supply voltage link selection is correctly set.
- All other link positions are correct.
- The supply fuse(s) are of the correct type and value.
- All wiring and connections have been made according to the specifications detailed in this manual.
- Enclosure lid(s) are fitted, before applying power to the controller(s).
- All metal 'bodied' parts of the system are correctly connected to earth.
- All cables, where required, are of the correct 'braided screen' specification and terminated as defined in this manual.

---

## 4. Commissioning the controller.

---



### **WARNING**

- While the control is operating in commissioning mode certain safety checks cannot be performed by the control and therefore the safety of the system operation is the sole responsibility of the commissioning engineer.
- Ensure that water level control limits are within the sight-glass limits on the boiler.
- Do not allow water levels in the boiler to reach unsafe levels.
- Where operating times are adjustable ensure that those selected are

#### 4.1 General

The NXEXP300, with or without the NXDBWLC daughterboard, is commissioned via the NX6100/PPC6000 burner controller by selecting commission mode from the Touchscreen display module. The Expansion Module follows the commission status of the NX6100/PPC6000 controller. Two passcodes are available for this purpose. The NXEXP300 requires the use of the NXTSD104 touch screen display, the NX6220 or NX6330 12 key keypad for programming.

- *Supplier passcode* - allows entry to all commissioning modes.
- *Site passcode* - allows adjustment of some option parameters.

#### 4.2 Commissioning data

##### 4.2.1 Option parameters

The NXEXP300 is configured by programming Option Parameters (memory registers) that describe the configuration of the burner and the boiler. Option parameters are set and adjusted in *Option Set* mode, but it may not be possible to adjust all of them if the burner is on.



## 4.3 The Commissioning process.

### 4.3.1.1 Entering commission mode via NXTSD104 Touch Screen Display

To enter the passcode, press **MENU**, then **BURNER SETTING**, then the **COM** button. This will prompt the keypad pane to appear, allowing the relevant passcode to be entered using the soft keypad and confirmed by pressing the **OK** button.

NOTE: The Supplier's Passcode (LV3) is six digits. Enter ALL, including any zeros, followed by the **OK** button.

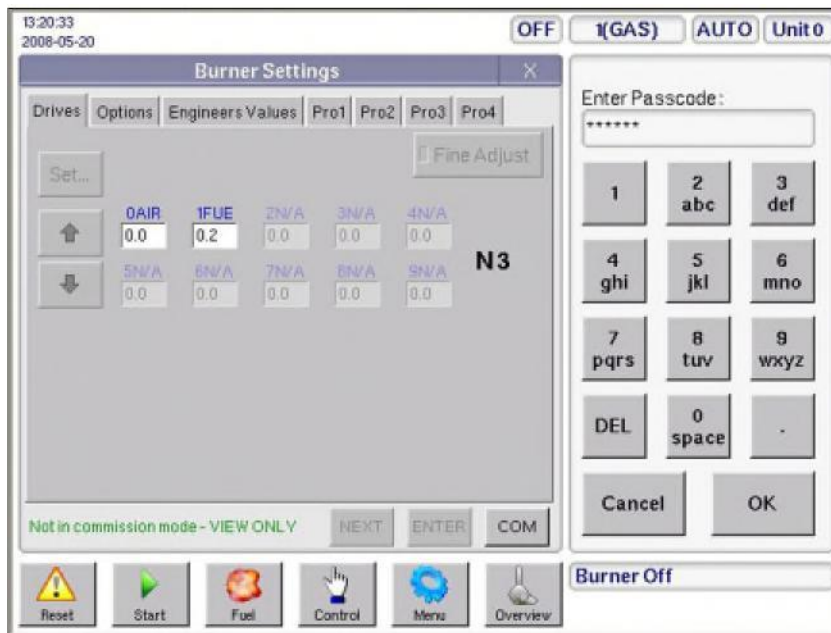

Option parameters associated with the NXEXP300 Water Level/Expansion Module are found within the "Menu" button under "Boiler Water Control" button.

**NOTE: This key is unavailable until the NXEXP300 is connected and Option 43.0 and 43.1 are set. See Option Parameters.**

### 4.3.1.2 Entering Commissioning Mode via NX6220/NX6330 12 Key Display

- 1: Press the F4 function key. The following will appear; Enter Passcode: 000 xxx.
- 2: Press the down cursor key until the first three digits of the Suppliers Passcode (LV3) appear, then press the F4 key. The following will appear; Enter Suppliers Passcode: +++000.
- 3: Press the up-cursor key until the last three digits of the Suppliers Passcode (LV3) appear, then press the F4 key. Proceed to option 43.0 and 43.10 and set them to the correct value



#### 4.4 Using option set mode

- Use the UP/DOWN keys to select the Option parameter to be adjusted.
- Use the Scroll (< >) keys to navigate between Option numbers and the Option values.
- Use the UP/DOWN keys to change the value of the option parameter. When the correct value is selected then press the ENTER key to store the new value.
- Set or adjust all the parameters as required by moving between the parameters and adjusting as detailed above.



## 4.5 Option parameter list



### CAUTION

- Use extreme care when entering option parameters. Incorrect data entry could cause a hazardous situation to occur.

Note: If an option parameter is marked with ‘\*’, it is not possible to adjust its value using the site passcode. If an option parameter in the following list is marked with ‘#’, then it will only be possible to adjust its value when the burner is OFF.

**ALL PARAMETERS DEFAULT TO ZERO UNLESS OTHERWISE SPECIFIED.**

**Option 43.0 – \* Enable Water level / expansion unit – Set to 3 or 4 ONLY! LV3**  
DEFAULT; 0

Parameter 6.0	Drive Options
1	<i>Reserved</i>
2	<i>Reserved</i>
3	WLC with no low limits.
4	Sequence draft and fail-safe digital inputs and abacus programs. No WLC function,
5	<i>Reserved</i>
6	<i>Reserved</i>
7	<i>Reserved</i>

\* This option is found in NX6100/PPC6000

**Option 43.1 – \* \*\* Unit Address of Water level/ expansion unit - Set to 10. LV3**

\* This option is found in NX6100/PPC6000

\*\* For options 43.0 and 43.1 - Firmware 1.039 or later.

**WARNING: Once set to a value > 0, this option cannot be turned off without using a special “Restore 817” value. See option 45 for details. Changing this value back to 0 results in disabling any safety inputs, such as a low water cut off, that may be wired to the NXEXP300 expansion module. Be sure to check that no safety will be compromised if the NXEXP300 is disabled.**

**Option 50.2 – NXEXP300 serial communications address (0 - 15) \* #**

DEFAULT: 10

If the controller is to be connected to other equipment via the serial communications interface, it must be given a unique address using this option parameter. Additionally, if more than one controller is connected on the CAN bus (for example to share a display), the controllers must all have unique addresses BEFORE THEY ARE CONNECTED TO THE SAME CANBUS.

NOTE: Comfire version 2.2.7 and higher will read the NXEXP300 options and assumes that an address of 10 is in fact, an expansion module. If there is a PPC/NX6100 in a sequencing arrangement with address 10,



Comefire will treat it as an NXEXP300. To read the PPC/NX61000 data, you will need to temporarily change the PPC;/NX6100 Unit Address (Option 0.2) to another value besides 10

**The Expansion Module unit address MUST be the same as option 43.1 above.**

**NOTE:** Once enabled, Option 43 cannot be set to 0. To remove the NXEXP300 from the system, Option 45.0 in the NX6100/PPC6000 must be enabled and, 45.2 must be set to 817. Then, exit and re-enter commission mode. At this time, Option 43 can be set to 0.

**WARNING:** Any safety interlocks previously monitored through the NXEXP300 will no longer be active once option 43 is reset to 0. Use this feature carefully!

**Option 50.7 – Modbus device address (0-99) \* #DEFAULT: 0**

This option sets the Modbus device address for the controller. Note that Modbus communications are only available when the NXDBWLC daughterboard is fitted. Without the XDBWLC, access to these settings is available through Modbus TCP/IP or BACnet only. Modbus TCP/IP and BACnet require either the NXTSD104 (10.4" Color Touch Screen) or NX6330 12 key Keypad display (consult factory for availability).

**Option 50.8 – Modbus Communication speed (0-3) \* #**

DEFAULT: 0

This option sets the Modbus communication speed as follows:

Option value	Speed bits/s
0	9600
1	4800
2	9600
3	19200

**WLC → Option 51.0 – Water Level measurement type (1/4)\* #**

DEFAULT: 3

Water level measurement may be determined in two different modes as follows:

Parameter 6.0	Drive Options
1	Reserved
2	Reserved
3 [DEFAULT]	WLC with no low limits. - DEFAULT
4	No WLC function, just fail-safe digital inputs and abacus programs

**DO NOT** press the minimum/maximum number that appears after selecting the value.

**Option 51.1 – Keyboard Auto/Manual enable (0 - 1) \***

DEFAULT: 1

It is possible to enable/disable the auto/man facility from the keyboard. Selecting a 0 will disable the operation of the 'auto/man' function from the keyboard. Selecting a 1 will enable the operation of the 'auto/man' function from the keyboard.

**WLC → Option 52.0 – Sight Glass Height \***

For the touchscreen to accurately mimic the actual sight glass on the boiler, the system needs to have the actual sight glass height entered here. This would typically be entered in inches.

Once this, and Option Parameters 52.1 and 52.2, are entered it is possible for the alignment of the mimic sight glass to be adjusted from the screen directly using the 'align' button, in commission mode.

**WLC → Option 52.1 - Element 1 zero (4 ma) value \***

Set this option to the value represented by the 4mA level of water level transmitter number 1.

**WLC → Option 52.2 - Element 1 span (20 ma) value \***

Set this option to the value represented by the 20mA level of water level transmitter number 1.

**Option 52.3 - Element 2 zero (4 ma) value \***

Set this option to the value represented by the 4mA level of water level transmitter number 2.

**Option 52.4 - Element 2 span (20 ma) value \***

Set this option to the value represented by the 20mA level of water level transmitter number 2.

**Option 52.5 thru 52.9 - Reserved**

**WLC → Option 53.x – Feedwater Drive Serial Number \* #**



**CAUTION**

- The total electrical load for all connected servo motors **must not** exceed 40VA.

Each servo motor connected to controller has a unique serial number allocated to it during manufacture. This number cannot be changed and is used to uniquely identify each drive.

When the system is in commissioning mode, the serial number of all the connected drives is read by the controller and displayed as a 'list' to allow the selection of the relevant servo motor for each drive (0 – 9) to be made.



Scrolling the list in an upward direction will scroll through all drive options available until '0, No Drive' is displayed. Enter this value to disconnect the specified drive from any hardware.

Scrolling the list in a downward direction will stop when the currently selected item is displayed, and the value will stop flashing.

The display will show type information for each drive present (such as the torque rating of a servo). Before setting these parameters, the commissioning engineer should be aware of each servo type and serial number that is connected to the burner.

For Option Parameters 53.0, 53.1 and 53.2 (select a serial number for a servo drive)

If a 4-20mA output is required, selections can additionally be made for:

- 5 - TDS daughterboard output. This requires NXDBWLC
- 9 - Burner (PPC/NX) daughterboard output 1. Requires NXDBVSD in PPC/NX control.
- 10 - Burner (PPC/NX) daughterboard output 2. Requires NXDBVSD in PPC/NX control.
- 11 - Burner (PPC/NX) daughterboard output 3. Requires NXDBVSD in PPC/NX control.

**NOTE: Selections 9, 10 and 11 will only work if the corresponding output is not used for any other function in the PPC/NX burner control itself - max 250 Ohm impedance**

**WLC → Option 53.0 – Feedwater Control Drive \***

Select a serial number and/or analog output for this drive.

**DRAFT → Option 53.1 – Draft Control Drive\***

Select a serial number and/or analog output for this drive.

**Option 53.2 – AUX Drive \***

This option parameter is available for future expansion and/or special projects  
Select a serial number and/or analog output for this drive.

**WLC → Option 54.0 – Modulating feed water mode \***

Allows for use of servomotor or 4-20mA feed water control.

Parameter 54.0	Selections
0	ON / OFF pump control only
1	Modulating feed pump. An inverter is used to drive a feed pump. If the output is below a minimum set value (see option parameter 54.1), the pump will be turned off.
2 <b>max 250 Ohm impedance</b>	Modulating feed valve. Water is delivered to the boiler using a valve controlled either via a 4-20mA output, or directly with a can bus servo.
3	Continuous pump. The WD2/3 output for the selected pump will stay on always (except high limit) in this mode but the cut-in and cut-out limits as used for mode 0 and 1 are available and control WZ9/10 for the boiler isolation valve. This can be used in conjunction with 54.1 (minimum pump speed) but that can (now) be set to zero if not needed.



**Option 54.1 – Modulating pump minimum output \***

**NOTE: Only available if 54.0 = 1.**

As described in 54.0 = 1 above, the set value is in % of output. For example: 50 would cause the pump to be turned off until the feedwater system required more than 50% output.

**Option 54.2 – Modulating run on time**

Pump run on time and modified action when 54.0 = 3 (continuous pump mode) to allow for circulating pump with boiler isolation valve.

**Option 55.0 – Modulating Feed-water Drive Direction \* #**

This parameter is used to specify direction for each servo drive. This parameter has no effect for variable speed drives (VSD). If this parameter is changed, then the effected profiles must be re-commissioned by a qualified engineer.

Parameter 55.0	Drive Options
0	Drive moves anticlockwise
1	Drive moves clockwise./ Ramp Time

NOTE: If Draft damper drive is a 4-20mA drive (electric / pneumatic) setting this to 1 or greater slows the drive down by that number of seconds.

E.g.: 30 would add 30 seconds of “ramp” time to the output

**Option 55.1 – Draft Control Drive Direction \***

Parameter 55.1	Drive Options
0	Drive moves anticlockwise
1	Drive moves clockwise

NOTE: If Draft damper drive is a 4-20mA drive (electric / pneumatic) setting this to 1 or greater slows the drive down by that number of seconds.

E.g.: 30 would add 30 seconds of “ramp” time to the output

**Option 55.2 – AUX Drive Direction \***

Parameter 55.2	Drive Options
0	Drive moves anticlockwise
1	Drive moves clockwise

**Option 56.x – Reserved**

**Option 57.0 and 57.1 – Reserved**



**Option 57.2 – Low water alarm ON point (-99.9 to 99.9)**

This option is used for low water alarm ON/OFF control. Once the water level drops below this level, the low-water alarm will turn on.

**Option 57.3 – Water (Drum) level set-point (-99.9 to 99.9)**

The desired or ideal water level. Typically, this would be halfway between the Pump ON and Pump OFF values. For simple on-off control, this value has no effect.

**Option 57.4 – Low water alarm OFF point (-99.9 to 99.9)**

Once the water level exceeds this value, the low water alarm will turn off (become clearable).

**Option 57.5 – High water alarm ON point (-99.9 to 99.9) \* #.**

If the water level exceeds this value for three seconds, the system will alarm but keep running.

**Option 57.6 – High High water level limit (-99.9 to 99.9) \* #**

If the water level exceeds this value for three seconds, the system will lockout.

**NOTE: If this is NOT required, set this value to 99 (disabled).**

**Option 57.7 – Pump ON water level when the boiler is off (-99.9 to 99.9)**

If the boiler is off, then once the water level drops below this level, the feed-water pump relay will turn on.

NOT available in modulating feed water mode.

**ONLY** available if Option 54.0 = 0 or 1 (not 2)

**Option 57.8 – Pump OFF water level when the boiler is off (-99.9 to 99.9)**

If the boiler is off, then once the water level exceeds this value, the feed water pump relay will turn off.

NOT available in modulating feed water mode.

**ONLY** available if Option 54.0 = 0 or 1 (not 2)



#### **Option 58.0 – Second feed pump enable (0 - 1) \* #**

Normally the feed pump is turned on and off as required using output WD2. If a second (backup) feed pump is installed, it can be controlled from output WD3. If this option is set to 1, the system recognizes that a second feed pump is available and option parameters 58.1 to 58.2 become available.

#### **Option 58.1 – Pump select input (1 - 16) \* #**

Choose a digital input to select the feed water pump. If the selected input is on, the second pump is selected. If this parameter is left at zero, the pump can be controlled manually from the display touchscreen, and/or automatically switched by option parameter 58.2 and by a feed-water pressure switch alarm (see parameter 63.0).

#### **Option 58.2 – Pump switch–over time (0-999 hours) \* #**

If option parameter 58.1 is zero, and a time (in hours) entered here, then the system will switch over automatically between pump 1 and pump 2 at the period specified. The system will also switch pumps if the pump that is off is enabled via the touchscreen. This will also reset the change-over timer.

#### **Option 58.3 – Water feed pump 1 trip input (0 to 16) \* #**

If this parameter is non-zero and the input selected goes off. F116 "Pump1 Trip" alarm will be displayed on the display and pump 2 will be selected. The fault activation time is 3 seconds.

#### **Option 58.4 – Water feed pump 2 trip input (0 to 16) \* #**

If this parameter is non-zero and the input selected goes off. F117 "Pump2 Trip" alarm will be displayed on the display and pump 1 will be selected if that pump is not already tripped. The fault activation time is 3 seconds.

#### **Option 60.0 – TDS enable (0 - 1) \* #**

Set this option to 1 to enable TDS measurements via the inputs on the daughterboard.

#### **Option 60.1 – TDS Calibration value (0 – 9999) \* #**

**NOTE: Fireeye recommends resetting TDS calibration monthly as conditions warrant.**

Set this value to indicate the ppm value of the calibration sample. The value set is in actual TDS ppm, e.g. 1500 for 1500ppm. This value is entered before the AUTO calibration (Option 60.2) is enabled. Changing this value *without* recalibrating, will have *NO* effect.

#### **Option 60.2 - TDS Calibration initiate (0 - 1) \* #**

On initial setup, this option should be performed twice to increase accuracy. Set this option to 1 to start a calibration cycle. This automatic procedure determines the probe signal gain required to match the current TDS measurement against the value set in option 60.1



**Option 60.3 – Boiler water temperature (0 - 360) \* #**

Set this option to a value 0 if a PT100 probe in the TDS measurement chamber is connected to the to daughterboard.

Set this option to a value 1 if the operating steam pressure is to be used to determine the TDS sample water temperature.

OR

Set this option to a temperature value to be used when determining the TDS level in a boiler water sample.

**Option 60.4 – TDS probe gain (0 - 999) \* #**

This option value defines the gain value for the TDS probe. This value is normally set by the calibration process, initiated by option 60.2.

**Option 60.5 – Surface blow-down limit ppm (0 - 999)**

If the TDS level reaches this limit, a surface blow-down cycle will be initiated. This will happen regardless of the value of parameter 62.1. If 62.1 is also set, the timer will be cleared.

**Option 60.6 – Surface blow-down limit ppm (0 - 999)**

If the TDS level reaches this limit, a surface blow-down cycle will be initiated. This will happen regardless of the value of parameter 62.1. If 62.1 is also set, the timer will be cleared.

**Option 60.7 – Read TDS from Blowdown (0 - 1)**

Set this option to a value of 1 if the TDS measurement is made during the surface blow-down cycle.

**Option 60.8 – HIGH TDS Level**

A TDS (Total Dissolved Solids) level above the value entered here causes a Lockout of the control after 15 seconds.

(F115 High TDS)

**NOTE: Requires update to touchscreen (3.004) to show the correct fault message.**

**Option 60.9 – TDS filter time (1 to 60 minutes).**

**Option 61.1 – Surface blow-down maximum time interval (0-72 hours)**

If non-zero, a surface blow-down cycle will be performed at the specified interval, or more frequently if required by TDS. Range 0.1 (6 minutes) to 99.9 hours (99 hours, 54 minutes)



### **Option 61.2 – Surface blow-down minimum time interval (0-60 minutes)**

Surface blow-down cycles will always have a gap of at least these many minutes between them, regardless of TDS. 0-60 minutes

### **Option 61.3 – Surface blow-down length (0-360 seconds)**

Surface blow-down length (seconds). The surface blow-down relay output will be energised for these many seconds, for one cycle.

### **Option 62.1 - Bottom blow-down maximum time interval (0-99 hours)**

If non-zero, a bottom blow-down cycle will be performed at the specified interval, or more frequently if required by TDS.

### **Option 62.2 – Bottom blow-down minimum time interval (0-99 minutes)**

Bottom blow-down minimum time interval (minutes). Bottom blow-down cycles will always have a gap of at least these many minutes between them, regardless of TDS.

### **Option 62.3 – Bottom blow-down length (0-99 seconds)**

The bottom blow-down relay output will be energised for these many seconds, for one cycle.

### **Option 62.4 – Bottom blow-down HOLD OFF input**

### **Option 62.6 – Bottom blow-down microswitch OFF**

F130 alarms [Indicates without lockout] if the input selected in 62.6 is  
Off when the valve is closed or  
On when the valve is open

NOTE: Requires update to touchscreen (3.004) for the alarms to announce properly and to show the correct text for the fault message.

### **Option 62.7 – Bottom blow-down microswitch ON**

F131 alarms [Indicates without lockout] if the input selected in 62.7 is  
On when the valve is closed or  
Off when the valve is open

NOTE: Requires update to touchscreen (3.004) for the alarms to announce properly and to show the correct text for the fault message.

### **Option 62.8 – Cut-in point**

Cut in points for an expansion driven bottom blowdown to operate based on the level. A fixed 2-minute time limit is set.

### **Option 62.9 – Cut-out point**

Cut-out points for an expansion driven bottom blowdown to operate based on the level. A fixed 2-minute time limit is set.



### **Option 63.0 – Feed-water low pressure input. (0 – 13) \* #**

If the digital input specified turns off (open circuit) when the pump should be on, a low feed-water pressure alarm will be generated.

If parameter 58.0 is set for two pumps, and they are not switched externally (parameter 58.1 = 0), then the pump will be swapped automatically.

### **Option 63.1 – Pump off input**

Allow an input to be specified that will hold the water pump off if it goes off.

### **Option 63.2 – Pump off input**

Allow an input to be specified that will hold the water pump off if it goes off.

### **Option 63.3 – Pump off input**

Allow an input to be specified that will hold the water pump off if it goes off.

### **Option 64 – Reserved**

### **Option 65 – Reserved**

### **Option 66.3 – High voltage Input 12 Alarm / Lockout Function (0 - 360) \* #**

This option parameter works identically to option parameters 68.1 to 68.9, except that it relates to the high voltage input 12, WE4 ON THE NXEXP300.

### **Option 66.4 – High voltage Input 13 Alarm / Lockout Function (0 - 360) \* #**

This option parameter works identically to option parameters 68.1 to 68.9, except that it relates to the high voltage input 13, WE5 ON THE NXEXP300.

### **Option 66.5 – High voltage Input 12 Fail-safe Alarm / Lockout Display Messages(0 - 999) \* #**

This option parameter works identically to option parameters 69.1 to 69.9, except that it relates to the high voltage input 12, WE4 ON THE NXEXP300.

### **Option 66.6 – High voltage Input 13 Fail-safe Alarm / Lockout Display Messages(0 - 999) \* #**

This option parameter works identically to option parameters 69.1 to 69.9, except that it relates to the high voltage input 13, WE5 ON THE NXEXP300.

### **Option 68.1 to 68.8 – Fail-safe Alarm / Lockout Inputs (0 – 360) - also 66.3 & 66.4 \* #**

The fail-safe digital inputs may be used to lockout or shutdown the burner, by the opening of a contact across the input terminals. This event will generate a fault or limit number which relates directly to the input that caused the event (changing to open circuit). Thus, F71 comes from input 1, F78 comes from input 8 and F83 comes from input 13.

The shutdown or lockout functions are activated by setting a number into option parameters 68.1 to 68.8 for inputs 1 to 8, and option parameters 66.3 & 66.4 for inputs 12 & 13. The number is a one-, two- or three-digit number defined as follows - zero gives no function.



HUNDREDS (fault type)	TENS (fuel type)	UNITS (burner status type)
0 – This alarm will <b>Lockout</b> the burner and shows on the display as 'FXX'. Manual intervention (Mute/Reset) is required to restart the burner once the fault condition has cleared. The burner will lockout within <b>one</b> second.	0 or 1 – Fault will be active for any fuel selection (including no fuel selected at all).	0 or 1 – Fault will be active regardless of the current burner status (i.e. all the time).
1 – This alarm will shut down the burner and show on the display as 'Lxx'. When the event condition clears, this code will change to 'CXX' and the burner will restart without manual intervention. The burner will shut down within <b>three</b> seconds.	2– Fault will be active only when the currently selected profile fires GAS	2– Fault will be active after the fan has started, the air pressure switch has made, and the drives have made their purge positions (i.e. once pre-purge starts). Not active during post purge.
2– This alarm is for indication only. It will appear on the display as 'LXX' but will not stop the burner operating. The limit will operate within <b>three</b> seconds.	3 – Fault will be active only when the currently selected profile fires GAS.	3– Fault will be active after pre-purge has finished (i.e. drives moving to the ignition position). Not active during post purge.
3-This operates the same as selection 1 in this column, but the fault will be generated when the input closes. <b>This mode of operation must not be used for any safety function because if the wire breaks, it cannot be detected.</b>	4– Fault will be active only when there is a fuel profile currently selected (either firing GAS or OIL).	4 – Fault will be active after pilot ignition has started (status 11 onwards). Not active during post purge.
4-This alarm will <b>Lockout</b> the burner and shows on the display as 'FXX'. Manual intervention (Mute/Reset) is required to restart the burner once the fault condition has cleared. The burner will lockout within <b>three</b> seconds	<b>All other values will work like selection 1 (including zero). 5 to 9 are spare so new functions can be added later</b>	5 – Fault will be active after main ignition has started (status 13 onwards). Not active during post purge.
<b>5 to 9 are spare and can't be selected.</b>	<b>All other values will work like selection 1 (including zero). 5 to 9 are spare so new functions can be added later</b>	6-Fault will be active after the drives have reached their low fire positions and the burner is ready to modulate (status 16). Not active during post purge.
<b>5 to 9 are spare and can't be selected</b>	<b>All other values will work like selection 1 (including zero). 5 to 9 are spare so new functions can be added later</b>	7-Fault will be active at IGNITION only (burner status 10 to 14 inclusive)
<b>5 to 9 are spare and can't be selected</b>	<b>All other values will work like selection 1 (including zero). 5 to 9 are spare so new functions</b>	8 – Fault will be active at pre-purge only.
<b>5 to 9 are spare and can't be selected.</b>	<b>All other values will work like selection 1 (including zero). 5 to 9 are spare so new functions can be added later.</b>	<b>All other values will work like selection 1 (including zero). 7 to 9 are spare so new functions can be added later.</b>



Option parameter number	Digital Input Number/ Terminals	Fault number
68.1	Input 1 WB9 to WB10, LOW VOLTAGE	F71 or L71
68.2	Input 2 - WB9 to WB11, LOW VOLTAGE	F72 or L72
68.3	Input 3 - WB9 to WB12, LOW VOLTAGE	F73 or L73
68.4	Input 4 - WB9 to WB13, LOW VOLTAGE	F74 or L74
68.5	Input 5 - WB14 to WB15, LOW VOLTAGE	F75 or L75
68.6	Input 6 - WB14 to WB16, LOW VOLTAGE	F76 or L76
68.7 HFPS (High Furnace Pressure Switch)	Input 7 - WB14 to WB17, LOW VOLTAGE  <b>NOTE:</b> If the NEX300 is used for draft control, this input should be connected to the Low Draft switch to avoid confusion. If draft Control is NOT used, this input can be used as desired.	F77 or L77  <b>NOTE :</b> This fault number F77 is shared with the low draft function (see option parameter 81.1).
68.8 LFPS (Low Furnace Pressure Switch)	Input 8 – WB6 to WB5, LOW VOLTAGE  <b>NOTE:</b> If the NEX300 is used for draft control, this input should be connected to the High Draft switch to avoid confusion. If draft Control is NOT used, this input can be used as desired.	F78 or L78  <b>NOTE :</b> This fault number F78 is shared with the high draft function (see option parameter 81.2).
66.3	Input 12 – WE4 to live, HIGH VOLTAGE	F70 or L70
66.4	Input 13 – WE5 to live, HIGH VOLTAGE	F79 or L79

Examples:

To set input 5 to give a 'high gas pressure lockout' you might enter 25 (025) into option parameter 68.5. This will give a lockout when gas is selected, and the main valve is open.

To set input 1 to give an 'extra low water' lockout you would enter 11 (or 1) into option parameter 68.1.

To set input 2 to give a 'high water alarm' you would set 211 (or 200 or 210 or 201) in option parameter 68.2.

### Option 69.1 to 69.9 – Fail-safe Alarm/ Lockout Display Messages\* and option parameters 66.5 & 66.6 \* #

These option parameters assign messages to the shutdown or lockout functions defined in options 68.1 to 68.8. The messages are chosen from a list of 32 possible items using option parameters 69.1 to 69.8 (for inputs 1 to 8) and option parameters 66.5 & 66.6 for the high voltage inputs (12 & 13). The list below details the preset messages.

69.x (or 66.5 / 66.6) value	Message
0	Alarm Input Open
1	Low Water
2	Extra Low Water
3	High Water
4	High Gas Pressure
5	Low Gas Pressure
6	High Oil Pressure



69.x (or 66.5 / 66.6) value	Message
7	Low Oil Pressure
8	High Oil Temp.
9	Low Oil Temp.
10	Low Atom.Media
11	High Temperature
12	Low Temperature
13	High Pressure
14	Low Pressure
15	Panel Switch Open
16	High Stack Temp.
17	Fan Interlock
18	End Switch Open
19	Oil Interlock
20	Gas Interlock
21	Forced Lockout
22	Extra High Water
23	Oil Gun Interlock
24	Low Draft
25	Burner Door Switch
26	Emergency Stop
27	Exit Damper closed
28	Low Water Flow
29	Low System Press
30	Excess Temp.
31	PM5 Shutdown
32	Feed Tank Low
33	Phase Failure
34	High Draft
35	Feed Pump 1 O/L
36	Feed Pump 2 O/L
37	Blower Motor O/L
38	Low Furnace Pressure
39	High Furnace Pressure
40	W/D Timer Fault
41	Low Pilot Press
42	High Pilot Press
43	Fan VSD Tripped
44	Pmp1 VSD Tripped
45	Pmp2 VSD Tripped
46	High BioGas Press
47	Low BioGas Press
48	BioG Bster Tripped



**WLC → Option 70.0 – Water level Proportional band (0 – 999 (99.9”))**

This is the span of the proportional band that is used by the PID control loop for the feed-water pump or valve. This is the deviation from set point in inches.

**WLC → Option 70.1 – Water level Integral time (seconds)**

This is the integral time used in the PID control loop for the feed-water pump or valve. It may be set to any value from 0 to 999, seconds. If a value of 0 is entered the integral function is disabled, otherwise the time entered is the number of seconds the PID system will take to give an additional modulation change equal to that currently given by the proportional term. Integral control is required for the water level to respond to load changes accurately reach its setpoint. The lower the number (apart from zero), the more affect the integral function has. A large number will cause the integral term to act very slowly.

**WLC → Option 70.2 – Water level Derivative time (seconds)**

This is the derivative time used in the PID control loop for the feed-water pump or valve. It may be set to any value from 0 to 999. A value of zero will disable the derivative function. A non-zero value will have the effect of ‘advancing’ the modulation rate change caused by a constantly changing measured value by the number of seconds given. A low value will have little effect; a large value will cause a large effect.

**NOTE: This term is NOT normally required and should be carefully applied to avoid unstable operations.**

**Option 71.0 – Pump ON / Valve Open Input.**

If a digital input is selected here and it is turned ON, the output from the water level control will go to 100%.

**Option 71.1 – Pump OFF / Valve Closed Input.**

If a digital input is selected here and it is turned ON, the output from the water level control will go to 0%.

**Option 72.0 – 74.0 – Analog Input Function**

Ability to add 4-20mA input's that can be optioned up to display values on the screen and set alarm limits on them.



### **Option 75.0 – Feedwater Flow Input (Element 3)**

Ability to add 4-20mA input's that can be optioned up to display values on the screen and set alarm limits on them.

If there is a 4-20mA signal representing feedwater flow available, enter the analog input number here. This will enable three element feedwater control if steam flow is also available.

**NOTE: To disable 3 element control, this option must be set to 0**

### **Option 75.1 – Feedwater Flow Zero (Element 3)**

### **Option 75.2 – Feedwater Flow Span (Element 3)**

Zero / span for the feedwater flow input. The range is 0.00 to 99.99.

### **Option 75.3 – Feedwater Flow Maximum**

**NOTE THIS PARAMETER IS REQUIRED FOR 2 ELEMENT FEEDWATER CONTROL EVEN IF THERE IS NO FEEDWATER FLOW MEASUREMENT.**

Enter the approximate feedwater flow provided when the valve / pump output is at 100%.

This must be in the same units / scaled the same as the steam flow since the action of the two-element control is to attempt to balance steam and water flow.

### **Option 75.4 – Feedwater Flow PID Proportional Band**

**NOTE Enter in the same units used to measure the Feedwater Flow.**

### **Option 75.5 – Feedwater Flow PID Integral (I) time (seconds)**

### **Option 75.5 – Feedwater Flow Derivative (D) time (seconds)**

### **Option 76.0 – Reserved**

### **Option 77.0 – Steam Flow Input**

If there is a 4-20mA signal representing steam flow available, enter the analog input number here. This will enable two element feedwater control (or 3-element if feedwater flow is also available).

**Option 75.3 MUST BE SET TO ENABLE 2 ELEMENT CONTROL.**

**NOTE: To disable 2 element control, this option must be set to 0.**

### **Option 77.1 – Steam Flow Zero**

Zero for the Steam flow input. The range is 0.00 to 99.99.

This value represents Steam Flow x 1000.

### **Option 77.2 - Steam Flow Span**

Span for the Steam flow input. The range is 0.00 to 99.99.

This value represents Steam Flow x 1000.



**Option 78.0 – Reserved**

**Option 79.0 to 79.9 - Feedwater valve curve.**

If these parameters are left at zero, the feedwater valve is considered linear.

If at least 79.1 is set non-zero, then a characterization curve is applied to the output. In this case values ranging from 0 to 100 should be set in the parameters 79.0 to 79.9.

The following settings would give a linear valve (as used when no values are set) :

Option parameter number	Setting
79.0	0
79.1	11
79.2	22
79.3	33
79.4	44
79.5	55
79.6	66
79.7	77
79.8	88
79.9	100

**NOTE : THE DRAFT PRESSURE LIMITS ENTERED HERE ARE NOT FAIL-SAFE AND DO NOT PROVIDE A SAFETY FUNCTION. IF LOW/ HIGH DRAFT SAFETY LIMITS ARE REQUIRED THEN THESE MUST BE PROVIDED BY EXTERNAL PRESSURE MONITORING SYSTEMS. IF THESE ARE LIMIT SWITCHES THEN THEY MAY BE INTERFACED USING THE SAFETY INPUT FUNCTIONS ON THIS CONTROL OR THE PPC/NX.**

**SEE OPTION PARAMETERS 18.x / 16.x (NX/PPC) and 68.x / 66.x, (NXEXP300) RESPECTIVELY. ANY SUCH SYSTEMS MUST BE PERIODICALLY TESTED TO DETECT SWITCH FAILURES.**



**Option 80.0 - Draft Pressure Input**

If draft control is used, a 4-20mA input number must be entered here. (Range 1 – 3)



**Option 80.1 - Draft pressure zero / span.**

Range is -99.99 to +99.99. Typically, this would be entered in inches.



**Option 80.2 - Draft pressure zero / span.**

Range is -99.99 to +99.99. Typically, this would be entered in inches.



### **DRAFT** → **Option 80.3 - Draft Pressure Setpoint (Burner Firing)**

The required draft pressure when the burner is firing normally (modulating). If draft pressure is to be profiled over firing range (TBA) then the value entered should be the 'baseline' value.

Option Parameters 82.0 to 82.9 can be used to add or subtract from this at 10 points across the firing range so that the draft pressure can be profiled if necessary.

Range is -99.99 to +99.99. Typically, this would be entered in inches.

### **DRAFT** → **Option 80.4 - Draft Pressure Proportional Band**

For the draft control PID, this is the proportional band. If the setpoint is +0.50 and the P Band was set at 0.2 then the (proportional only) control would give:

+0.50 = damper fully closed.

+0.70 = damper fully open.

### **DRAFT** → **Option 80.5 - Draft Pressure Integral Time**

Standard PID 'I' time for draft control. Time is entered in seconds.

A value of zero give no integral action but other low values will give a very fast response. A value of 999 seconds gives the slowest response.

### **DRAFT** → **Option 80.6 - Draft Pressure Derivative Time**

Standard PID 'D' time for draft control. Time is entered in seconds.

A value of zero gives no derivative action. Low values give little derivative action. A value of 999 gives the maximum derivative response.

### **DRAFT** → **Option 80.7 – Outlet Damper Open Input**

(See Option Parameters 68.1 – 68.8, 66.3, 66.4)

Select a digital input here if a damper open microswitch is used.

When the PPC/NX requires the burner to start up, the expansion unit will keep its PE7 output off until this input comes on. This will have the effect of delaying the start (holding status 2) until the damper is fully open.

**NOTE THAT THIS IS NOT A SAFETY FUNCTION AND IF THE SWITCH FAILED PERMANENTLY CLOSED NO ALARM WOULD BE GENERATED.**

### **Option 80.8 - Draft High Fire Feed-forward.**

If a non-zero value is entered here, this will be added to the draft output at high fire. At 50% modulation, half this value will be added and at low fire, nothing will be added to the draft output.

A value of 10 will add 10% of span (so 9 degrees for a servo) to the damper position at high fire.



### Option 80.9 - BurnerlogiX Lockout Input.

(See Option Parameters 68.1 – 68.8, 66.3, 66.4)

In the event of a lockout of the PPC/NX the draft control damper will fully open for one minute, then close. If this action is also required for BurnerlogiX lockouts then a digital input must be selected here and interfaced to the BurnerlogiX lockout output.

**WARNING:** The BurnerlogiX alarm output is “**LINE VOLTAGE.**” Direct connection to terminal WE4, WE5 **ONLY**. Any other input requires an interposing relay.

### Option 81.0 - Draft Pressure Limits Enable

**NOTE :** THE DRAFT PRESSURE LIMITS ENTERED HERE ARE NOT FAIL-SAFE AND DO NOT PROVIDE A SAFETY FUNCTION. IF LOW/ HIGH DRAFT SAFETY LIMITS ARE REQUIRED THEN THESE MUST BE PROVIDED BY EXTERNAL PRESSURE MONITORING SYSTEMS. IF THESE ARE LIMIT SWITCHES THEN THEY MAY BE INTERFACED USING THE SAFETY INPUT FUNCTIONS ON THIS CONTROL OR THE PPC/NX.

**SEE OPTION PARAMETERS 18.x / 16.x (NX/PPC) and 68.x / 66.x (NXEXP300) RESPECTIVELY. ANY SUCH SYSTEMS MUST BE PERIODICALLY TESTED TO DETECT SWITCH FAILURES.**

#### Option 81.1 – Draft Low Limit

If the draft pressure drops below this value for 15 seconds (when the burner is running) then an F77 will lock out the burner.

**Note:** Option parameter 68.7 can also be used to generate a fault, F77. There is a possibility for confusion if both functions are used together. Therefore, use of both functions together is not recommended (although both functions will work together). It would be possible to use 68.7 to option up a low draft pressure safety function from a pressure switch and use this to generate F77 to avoid confusion.

#### Option 81.2 – Draft High Limit

If the draft pressure goes above this value for 15 seconds (when the burner is running) then an F78 will lock out the burner.

**Note:** Option parameter 68.8 can also be used to generate a fault, F78. There is a possibility for confusion if both functions are used together. Therefore, use of both functions together is not recommended (although both functions will work together). It would be possible to use 68.8 to option up a high draft pressure safety function from a pressure switch and use this to generate F78 to avoid confusion.

#### Option 81.8 – Draft Input Filter Time (s) 0 to 15.

Filter to smooth signal from the draft pressure sensor. Default Zero seconds would be no filtering

#### Option 81.9 – Ignition Draft Output (range 0 to 100%)

If set non-zero, this value will be used for the draft damper position during ignition (burner status 9 to 15). If left at zero, the damper will be fully opened during this time.



### Option 82.0 to 82.9 – Draft setpoint profiling

These parameters allow the profiling of the draft control setpoint across the firing range of the burner. Leave these parameters at zero if this function is not required. Otherwise, the values entered will be added to the draft setpoint depending on the firing rate of the burner. Negative values will cause the draft setpoint to be reduced accordingly.

Between the modulation points below, a linear interpolation is used so that 5% modulation, the setpoint modification will be approximately halfway between the value entered in 82.0 and 82.9.

Option parameter number	Setpoint modification
82.0	Setpoint modification at low fire.
82.1	Setpoint modification at 11% fire.
82.2	Setpoint modification at 22% fire.
82.3	Setpoint modification at 33% fire.
82.4	Setpoint modification at 44% fire.
82.5	Setpoint modification at 55% fire.
82.6	Setpoint modification at 66% fire.
82.7	Setpoint modification at 77% fire.
82.8	Setpoint modification at 88% fire.
82.9	Setpoint modification at high fire.

**RESTORE 817 in NX6100/PPC6000 - Requires Firmware version 1.300 or higher, see EK56.**

**Ability to retransmit values from WLC or burner control by 4-20mA outputs (using daughterboards)**

**WARNING: Setting the value in option 95.2 (45.2 in NX6100/PPC6000) to a value of 817 must be used with extreme caution. ANY interlocks wired to the NXEXP300 will be ignored once option 43.0 in NX6100/PPC6000 is reset to 0.**

This option allows the commissioning engineer to deselect the NXEXP300 by changing option 43.0 to a value of 0. After entering the value of 817, exit commissioning mode, then, without shutting the power to the control off, re-enter full commissioning mode. At this point, option 43.0 will allow a value of 0 to be entered. This disables the NXEXP300.

### Option 90.0 to 94.0 – Analog Output Function.

Ability to retransmit values from WLC or burner control by 4-20mA outputs (using daughterboards) or CANbus 4 -20 mA module (NX6230)

### Option 91.0 to 94.0 – Analog Output Function.

Ability to retransmit values from WLC or burner control by 4-20mA outputs (using daughterboards) or CANbus 4 -20 mA module (NX6230)

### Option 95.0 – Erase enable (0/1)

Set this option to a value 1 to enable option parameter 95.1 and the ability to erase the option parameters.

### Option 95.1 – Erase command (0 – 5)

Set this option parameter to a value 5 to in order to erase all the option parameters to their default values. The erase will happen when commission mode is exited.

Option 95.2 – Reserved.

This option parameter is reserved for future use and should be left at zero.

**NOTE: When erased, the original settings are gone forever!**

---

## 5. Feed-water pump speed control.

---

### 5.1 System configuration

The NXDBWLC daughter board controls the feed-water pump speed inverter using a 4-20mA output channel. The output is the speed reference signal to the inverter. In addition to the 4-20mA signal, the inverter also requires a motor start signal, which can be taken from the volt-free relay contacts on the daughter board, please ensure its function is set correctly using the relevant option parameter.

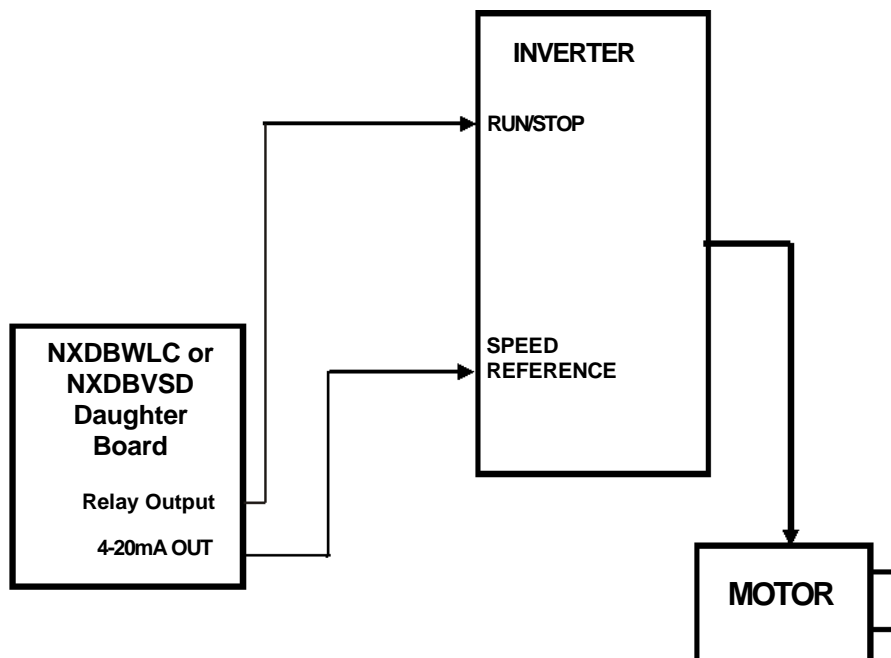



## 6. Faults and fault finding

### 6.1 NXEXP300 Expansion Module fault listing

No	Cause	Description
F70	External Alarm input WE4	Line Voltage
F71	External Alarm input WB10	One of the low voltage alarm / lockout inputs is causing an alarm.
F72	External Alarm input WB11	The fault may be prefixed by either an 'L' or an 'F' and may or may not shutdown / lockout the burner.
F73	External Alarm input WB12	See Option parameters 66.3, 66.4, and 68.1 to
F74	External Alarm input WB13	68.8. <i>Subset: burner status.</i>
F75	External Alarm input WB15	
F76	External Alarm input WB16	
F77	External Alarm input WB17	
F78	External Alarm input WB6	
F79	External Alarm input WE5	Line Voltage
F80	Extra Low water alarm	<b>NOT AVAILABLE ON NXEXP300.</b>
F81	First Low water alarm	A First Low water level has been detected. Alarm only. Alarm output on terminal WD4.
F82	High water alarm	A High-water level has been detected. Alarm only. Alarm output on terminal WD5.



No	Cause	Description
F83	Extra High-water alarm	An Extra High-water level has been detected. This will Lockout the burner until the condition recovers and the burner controller is reset.
F84	Expansion unit Fault	The NXEXP300 has signaled an internal fault to the burner controller, or the CAN link between the controllers has broken. Interrogate the Expansion unit for further information.  <i>Subset:</i> +0 -8 not responding correctly +16-Element 1 out of range +32 – Element mismatch, or a cross-check test has failed +64 – Low level cross-check failed
F115	Expansion unit Fault	High TDS Level See Option 60.8
F116	Expansion unit Fault	Pump1 Trip Alarm will be displayed on the HMI and pump 2 will be selected. The fault activation time is 3 seconds.
F117	Expansion unit Fault	Pump2 Trip Alarm will be displayed on the HMI and pump 1 will be selected if that pump is not already tripped. The fault activation time is 3 seconds.
F118	Expansion unit Fault	BOTH_PUMPS_TRIPPED_FAULT.
F130	Expansion unit Fault	Indicates without lockout if the input selected in 62.6 is Off when the valve is closed or On when the valve is open
F131	Expansion unit Fault	Indicates without lockout if the input selected in 62.7 is On when the valve is closed or Off when the valve is open



## 6.2 NXDBWLC fault listing

F49	Expansion unit fault.	The Expansion unit has received a fault indication from the daughterboard.  <i>Subset:</i> +1 = PT100 input too high +2 = PT100 input too low +4 = TDS input too high +8 = TDS input too high +16 = ADC reference out of range +32 = TDS probe gain out of range 255 = Daughter board communications fault
-----	-----------------------	---

## 6.3 The engineer's key

To access Engineers Keys for NXEXP300 – select the Water level control button from the main menu.

By selecting the engineer's key, it is possible to read the values of internal system variables and external input and output states. It is also possible to see the values of *fault subsets*, in order to obtain more detailed information about a fault that has occurred.

When using the engineer's key, it is not possible to change any parameters. Therefore, it is not possible to affect the operation of the burner.

After pressing the Engineer's Key:

- The top line of the display will show a EK (data register) number and the value of the register.
- The bottom line of the display will show the EK description.

For example.

```
EK025= 2  
Burner Status
```

- If there is a fault present, this will be shown on the right-hand side of the top line in the format 'F12,345' where 12 = fault number, and 345 = fault subset value. Note, this fault information will only be shown when viewing EK numbers 1 to 100.
- Use the UP/DOWN keys to change the EK number and view its corresponding data.
- Press the EK to index back to the normal display. The controller will revert automatically to the normal run display if a key has not been pressed for one minute.



### 6.3.1 Engineer's key parameter list

These Keys ONLY refer to the NXEXP300.

No.	Name	Description
EK1	Low Voltage Digital Input 1 WB9 – WB10	Shows the state of each input.  Where:  0 = OFF  1 = ON
EK2	Low Voltage Digital Input 2 WB9 – WB11	
EK3	Low Voltage Digital Input 3 WB9 – WB12	
EK4	Low Voltage Digital Input 4 WB9 – WB13	
EK5	Low Voltage Digital Input 5 WB14 – WB15	
EK6	Low Voltage Digital Input 6 WB14 – WB16	
EK7	Low Voltage Digital Input 7 WB14 – WB17	
EK8	Low Voltage Digital Input 8 WB5 – WB6	
EK9	Reserved	
EK10	Reserved	
EK11	Reserved	
EK12	High voltage digital input 12. WE4	
EK13	High voltage digital input 13. WE5	
EK14	Burner Select Input (High Voltage) WE6	
EK15 - 22	Reserved	
EK23	Draft Open mode	



No.	Name	Description
EK24 - 54	Reserved	
EK55	Main PCB issue	The issue number of the main circuit board
EK56	Firmware issue.	The current revision of the main product firmware.
EK57	Spare	N/A
EK58	CPU serial number (low 4 digits)	The CPU board serial number.
EK60		
EK61	Analog Input 1. Expansion unit Terminal WA7.	The raw ADC counts from analog input 1. 0 to 1023 for 0 to 5.00 volts. 4mA = 180 counts 20mA = 900 counts
EK62	Analog Input 2. Expansion unit Terminal WA8.	The raw ADC counts from analog input 2. 0 to 1023 for 0 to 5.00 volts. 4mA = 180 counts 20mA = 900 counts
EK63	Analog Input 3. Expansion unit Terminal WA9.	The raw ADC counts from analog input 3. 0 to 1023 for 0 to 5.00 volts. 4mA = 180 counts 20mA = 900 counts
EK64	Analog Input 4. Expansion unit Terminal WA12	The raw ADC counts from analog input 4. 0 to 1023 for 0 to 5.00 volts. 4mA = 180 counts 20mA = 900 counts
EK65	Analog Input 5. Expansion unit Terminal WA15	The raw ADC counts from analog input 5. 0 to 1023 for 0 to 5.00 volts. 4mA = 180 counts 20mA = 900 counts
EK66	Analog Input 6. Expansion unit Terminal WA19	The raw ADC counts from analog input 6. 0 to 1023 for 0 to 5.00 volts. 4mA = 180 counts 20mA = 900 counts
EK67		



No.	Name	Description
EK68		
EK69	Internal 24V low test	Expect approximately 256
EK70	Internal 24V high test	Expect approximately 864
EK71	NXDBWLC Daughter-board status	0 = no errors.
EK72	PT100 temperature reading	The value displayed here is the temperature in °C x 10. So, a value of 1250 represents 125°C.
EK74	CPU utilization (%).	The percentage utilization of the CPU. Should be less than 95% at all times.
EK77	Program size.	This is the size of the currently running manufacturer / user manufacturers program. If a user program is selected, this should match the program length given by the 'abacus' software.
EK80 - 89	Drive Error values for drives 0 to 9.	The current error value for drives 0 to 9. These values will freeze when the controller performs a safety shutdown, so it may be possible to look at these values after a lockout to help determine the cause.
EK90- Ek99	Spare	N/A
EK100	Firmware type PT22xxxx	This shows the last four digits of the firmware part number for the controller firmware. It is used for product variant identification.
EK101	Feed Water ON/OFF mode active	
EK102	Pump ON Input Active	
EK103	Pump OFF Input Active	
EK104	2 <sup>nd</sup> Element (steam) Active	
EK105	3 <sup>rd</sup> Element (feed flow) Active	



No.	Name	Description
EK120	Draft Wait Damper	
EK121	Low Draft Pressure reached	
EK122	High Draft Pressure reached	
EK123	Draft Panel Switch OFF	
EK151	Pump Cut-out (ON/OFF control only)	
EK152	Pump Cut-in (ON/OFF control only)	
EK154	Steam Flow	
EK155	1 <sup>st</sup> Element (level) output	
EK156	1 <sup>st</sup> and 2 <sup>nd</sup> Element output	
EK157	Feedwater Flow SP (3 element)	
EK159	2 <sup>nd</sup> Element (steam) output	
EK160	Level Output (raw)	
EK161	Level Output (linearized)	
EK170	Draft Pressure	
EK171	Draft Output	
EK172	Draft Setpoint	
EK200	WLC Control Program revision	



## 6.4 NOTES:



## 7. Technical specification

### 7.1 General

Supply voltage	120/230Vac +10% - 15%
Power consumption	Approx. 60VA
Supply frequency	50/60 Hz $\pm$ 5%
Ambient temperature range	32-140°F (0 to 60°C)
Controller protection category	IP20. The controller must be situated in a PD1 or PD2 environment according to EN6730-1. Indoor: Controller must be mounted in an IP40 enclosure Outdoor: Controller must be mounted in an IP54 enclosure
Mounting Attitude	Any
Cable Lengths	CANbus cable 100m, all others 10m maximum
Unit dimensions	Controller 8.27" x 4.92" x 3.15" (210 x 125 x 80mm deep)
Weight	Controller 4.7 lbs. (2.13kg)

### 7.2 Digital (Relay) outputs

Function: Various	115/ 230V On-off relay. From WE terminals. 115/ 230V On-off relay. From WD terminals.
Minimum current	200mA rms
Maximum current (per output)	4A rms (fused at 4A maximum)
Maximum voltage	250Vac rms
	Supplying circuits WE6 and WD1 must be able to carry sufficient current for all devices connected to the relay outputs and be fused at a maximum of 4A, unless each output is fused at 4A in which case the input fuse may be <b>8A MAX.</b>

\* **Maximum** total simultaneous current for these groups of outputs is **8A rms** for each group.



### 7.3 Digital inputs

Low Voltage digital inputs 1 to 7.	Low voltage dynamic digital inputs. The supply must be taken from the correct terminal as indicted in this manual. Do not apply external voltage
Maximum current	Less than 25mA at 5 vDC max.
Maximum voltage	±10V absolute maximum
High voltage inputs 12 & 13.	Digital, 0V for off, 90-264Vac for on.

### 7.4 Analog Inputs

4-20mA	
Maximum current	0 to 25mA maximum
Burden resistor	220 ohms nominal
Input accuracy (typical)	±1.1%
Input accuracy (as specified by EN12067)	±1.1%

### 7.5 Analog Outputs

Ambient temperature range	0 to 60°C (32 to 140°F)
Protection category	Not applicable (fits inside NX6100 unit).
Analog inputs (4 – 20mA)	3 max (non-isolated)
Input impedance	120ohms
Analog outputs (4 – 20mA)	3 max (isolated)
Maximum loop resistance	<b>4-20 mA at 250 Ohm max. impedance</b>
Isolation voltage	50v
RS485 communications.	FIREYE Protocol / Modbus RTU



## 7.6 NXDBWLC Daughter Board (optional)

Ambient temperature range	32-140°F (0 to 60°C)
Protection category	Not applicable (fits inside main controller).
TDS probe input	300K to 3K micro siemens
Accuracy	±0.1%
Accuracy (as specified by EN12067)	±0.2%
PT100 Temperature input	
Input impedance	120Ω
Accuracy	±0.4%
Accuracy (as specified by EN12067)	±0.5%
Auxiliary relay	
Type	On-off relay, de-energize for off.
Maximum current	100mA
Maximum voltage	50Vdc
Isolated RS485 communications.	
Protocol	Modbus RTU. 8-bit, no parity, 1 stop bit
Communications speed	Selectable - 4800, 9600, 19200 baud
Isolation Voltage	50Vdc
Analog Output WZ17, WZ18	<b>4-20 mA at 250 Ohm max. impedance</b>

## 7.7 Connections

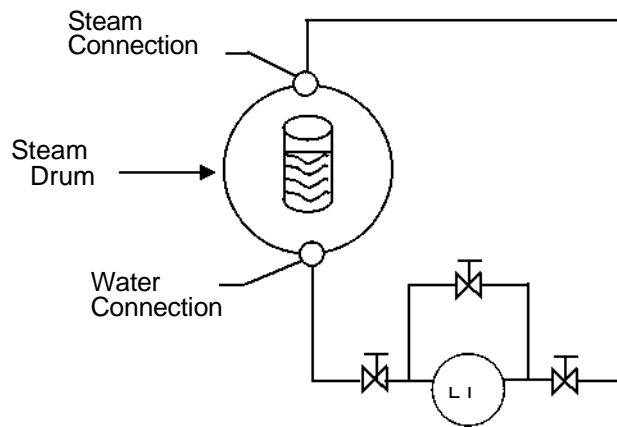

Typical Level Transmitter Piping

## 7.8 Approvals

Tested in accordance with the Gas Appliance Directive (GAD 90/396 EEC), encompassing the following standards:

- ANSI/UL 1995, Heating and Cooling Equipment
- CAN/CSA-C22.2 No. 236, Heating and Cooling Equipment
- FM \*
- ENV1954, Internal and external behavior of safety related electronic parts
- EN60730-1, Automatic electrical controls for household and similar use
- EN12067, Gas/air ratio controls for gas burners as gas burning appliances
- EN298, Gas or Liquid fuel appliances.

\* FM under Energy Technology Controls, Lewes, England model ETC6210, 6211

## 7.9 NXDBWLC Daughter Board

### **WARNING!**

THE NXDBWLC DAUGHTERBOARD MUST NOT BE MOUNTED IN EITHER THE PPC6000 OR NX6100.

THIS DAUGHTER BOARD IS MOUNTED IN THE NXEXP300.

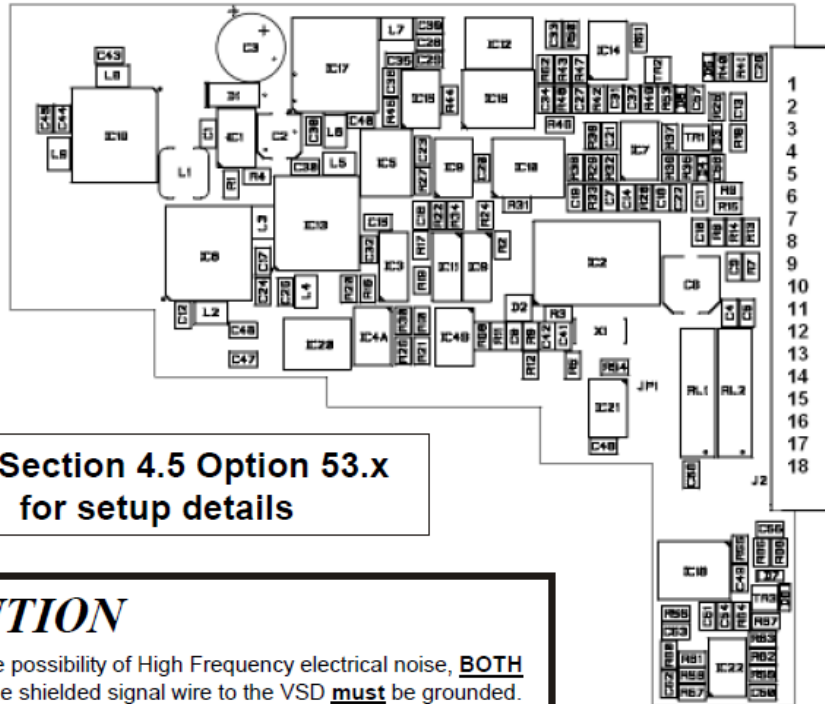

See Section 4.5 Option 53.x for setup details



### **CAUTION**

Due to the possibility of High Frequency electrical noise, **BOTH** ends of the shielded signal wire to the VSD **must** be grounded.

TDS +ve	WZ 1	TDS +
sense	WZ 2	TDS -
senses	WZ 3	TDS -ve
WZ 4	PT100+	WZ 5
PT100+	sense	WZ 6
PT100-	sense	WZ 7
PT100 -ve	WZ 8	Relay
50Vdc	WZ 9	Relay
50Vdc	WZ 10	Reserved
WZ 11	Reserved	WZ 12
Reserved	WZ 13	
Reserved	WZ 14	
Reserved	WZ 15	
Reserved	WZ 16	Feed
water pump speed	o/p	
+ve	WZ 17	Feed water
pump speed	o/p -ve	
WZ 18		

The cabling for all of these terminals MUST be overall 'braid' screened, PVC insulated, 7/0.2mm, 2-core. As this cable may lay adjacent to, and/or in the same conduit as Line voltage wiring, the cable voltage rating must exceed the maximum voltage carried by any other cable connected to the controller or run in the same conduit.

The function of the relay can be set by option parameter. **Note:** the maximum rating of the relay is 100mA at 50Vdc.

**Incorrect connection or application of excess voltage may damage or destroy the devices being connected.**

## 7.10 Variable Speed Drive (VSD) Daughter Board P/N NXDBVSD

### **WARNING!**

THE NXVSDDB DAUGHTERBOARD **MUST NOT BE MOUNTED IN THE NXEXP300.**

THIS DAUGHTER BOARD IS MOUNTED IN EITHER THE PPC6000 OR NX6100

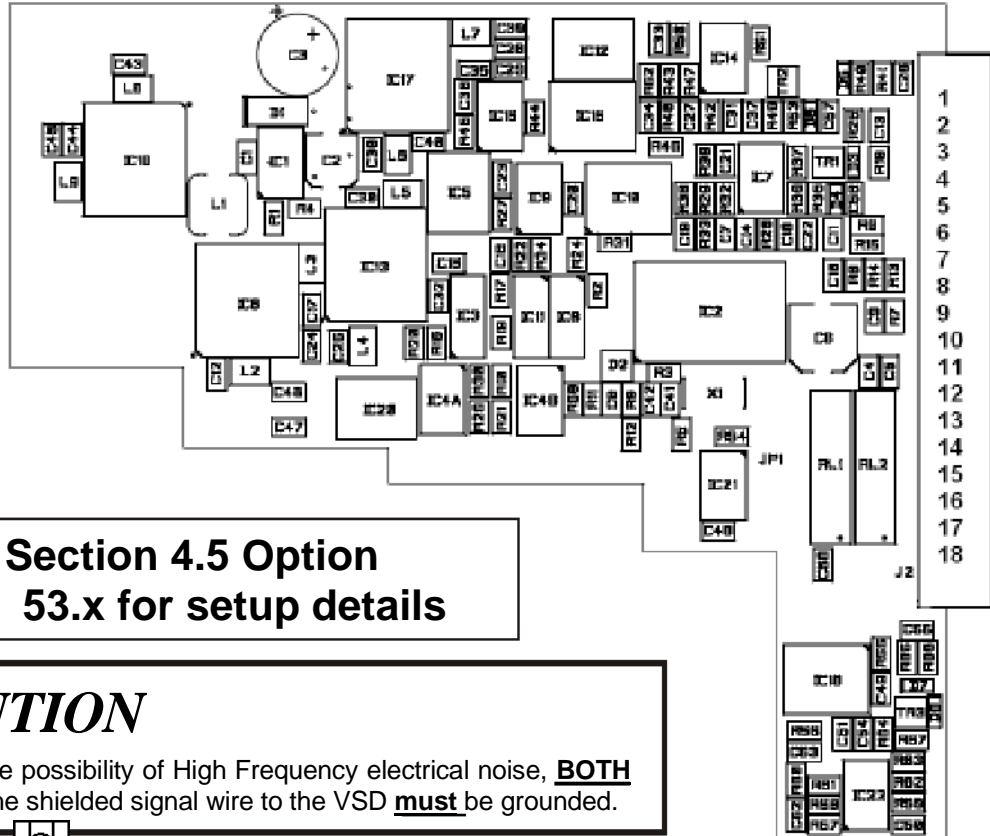

See Section 4.5 Option 53.x for setup details



### **CAUTION**

Due to the possibility of High Frequency electrical noise, **BOTH** ends of the shielded signal wire to the VSD **must** be grounded.

- 4-20mA Output Channel 1 – PZ 1
- 4-20mA Output Channel 1 + PZ 2
- 4-20mA Output Channel 2 – PZ 3
- 4-20mA Output Channel 2 + PZ 4
- 4-20mA Output Channel 3 – PZ 5
- 4-20mA Output Channel 3 + PZ 6
- Counter Input 1 PZ 7 +12Vdc PZ 8
- Counter Input 2 PZ 9 +12Vdc PZ
- 10 Counter Input 3 PZ 11 Input
- Channel 1 - PZ 12 Input Channel 1
- ± PZ13 Input Channel 2 + PZ14
- Relay 7 common PZ 15 Relay 7
- normally open PZ 16 Relay 8
- common PZ 17 Relay 8 normally
- open PZ 18

The cabling for all of these terminals must be 2-conductor (core) overall screened PVC insulated 24 AWG (7/0.2mm). Since this cable may be run in conduit with high voltage wiring, its voltage rating must exceed the maximum voltage carried by any other cable connected to the control or run in the same conduit.

The counter inputs are for use with encoder(s) for speed feedback from the devices being controller by the inverter(s) connected to the 4-20mA output(s) on this daughter board.

The analog outputs are isolated, but the analog inputs are not and therefore special precautions must be taken when using these inputs.

The inputs are for 4-20mA signals **must** be isolated as the second input connects 'on-top' of the first to ensure 'cross-talks' will be detected. Terminal PX13 alternates ± to be shared with PZ12 and PZ14. This "switching" detects a direct link between input 1 and input 2 which is not allowed.

The function of relay 1 & 2 can be set by option parameter, but please note the maximum rating of these relays is 200mA at 50V.

**Incorrect connection may damage or destroy the units being connected.**



## 8. NXEXP300 Terminal Layout

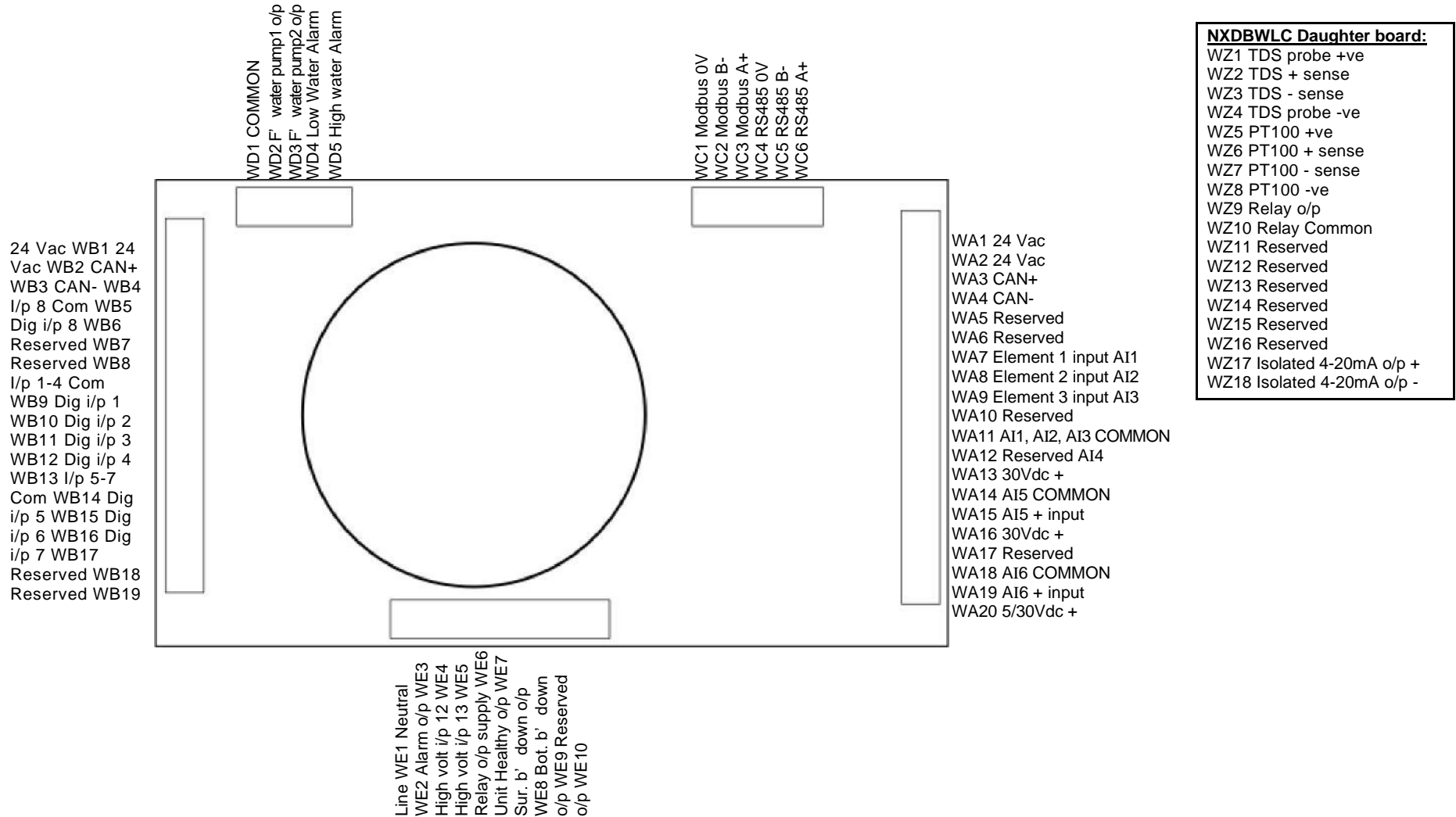



---

## **NOTICE**

When Fireeye products are combined with equipment manufactured by others and/or integrated into systems designed or manufactured by others, the Fireeye warranty, as stated in its General Terms & Conditions of Sale, pertains only to the Fireeye products and not to any other equipment or to the combined system or its overall performance.

---

## **WARRANTIES, EXCLUSIVE REMEDIES, AND LIMITATION OF DAMAGES**

Fireeye guarantees for one year from the date of installation or 18 months from the date of manufacture, whichever occurs first, to replace, or at its option, to repair any product or part thereof which Fireeye, in its sole discretion, deems to be defective in material or workmanship or which otherwise fails to conform to the description of the product on the face of its sales order. Fireeye's obligations pursuant to this warranty do not extend to any products or parts thereof which Fireeye determines to have been installed, operated, maintained, repaired, or altered improperly or otherwise than in conformity to Fireeye's applicable instructions, or which have been subject to misuse, accident, or neglect.

**THE FOREGOING IS IN LIEU OF ALL OTHER WARRANTIES, BOTH EXPRESS AND IMPLIED, INCLUDING THE WARRANTIES OF MERCHANTABILITY AND FITNESS FOR A PARTICULAR PURPOSE. EXCEPT AS SPECIFICALLY STATED IN THESE TERMS AND CONDITIONS OF SALE, REMEDIES WITH RESPECT TO ANY PRODUCT OR PART MANUFACTURED OR SOLD BY FIREYE, OR WITH RESPECT TO ANY BREACH OF OR DEFAULT UNDER THIS CONTRACT (INCLUDING ANY BREACH OF WARRANTY), SHALL BE LIMITED EXCLUSIVELY TO THE RIGHT TO REPLACEMENT OR REPAIR F.O.B. FIREYE MAIN WAREHOUSE LOCATION, AS ABOVE PROVIDED. IN NO EVENT SHALL FIREYE BE LIABLE FOR CONSEQUENTIAL OR SPECIAL DAMAGES OF ANY NATURE WHICH MAY ARISE IN CONNECTION WITH SUCH PRODUCT OR PART OR ANY BREACH OF OR DEFAULT UNDER THIS CONTRACT. TO THE EXTENT PERMITTED BY LAW, THE AGGREGATE LIABILITY OF FIREYE HEREUNDER WHETHER IN CONTRACT, TORT (INCLUDING NEGLIGENCE) OR OTHERWISE, WILL BE LIMITED TO ONE TIMES THE CONTRACT VALUE, PROVIDED HOWEVER THE FOREGOING LIMITATION DOES NOT LIMIT THE LIABILITY OF FIREYE FOR ANY INJURY TO, OR DEATH OF A PERSON, CAUSED BY THE GROSS NEGLIGENCE OF FIREYE.**