



# FIREYE MODULAR M-SERIES II

## FLAME SAFEGUARD CONTROLS



**WARNING:** Selection of this control for a particular application should be made by a competent professional, licensed by a state or other government agency. Inappropriate application of this product could result in an unsafe condition hazardous to life and property.

### DESCRIPTION

Fireeye® Modular M-Series II Flame Safeguard Controls are compact, modular burner management systems. They are designed to provide automatic ignition and continuous flame monitoring for commercial sizes of heating and process burners that use gas and/or light oil fuels.

Flame monitoring is accomplished by miniature UV scanners or Flame Rod detectors and plug-in amplifier and programmer modules which connect into a standard chassis and wiring base. Interchangeable programmer and amplifier modules allow for complete versatility in selection of control function, timing, and flame scanning means. Functions such as relight, two stage capability, non-recycle air flow, purge timing, and pilot cutoff are determined by the programmer module. Type of flame scanner (UV or Flame Rod) and Flame Failure Response Time (F.F.R.T.) are determined by the amplifier module.

Some programmer modules are equipped with a series of dipswitches to select Purge Timing, Pilot Trial For Ignition (P.T.F.I.) timing, and Recycle or Non-Recycle operation. LED indicator lights on all programmer modules indicate the operating status of the control.

In the event of ignition failure, or following a safety shutdown, the unit locks out, activating an alarm circuit. Manual reset is required. Remote reset (via remote pushbutton or power interruption) is available on the MC120R, MC120P and MC230R chassis. A detailed description of the various programmer modules is found later in this document. Test jacks are provided to permit flame signal measurement during operation. A “run-check” switch is provided on the MP560, MP561 and MP562 programmer modules to assist in testing size, position, and stabilization of the pilot.

Modular M-Series II controls incorporate a safety checking circuit that is operative on each start. If flame (real or simulated) is detected prior to a start or during the purge, the fuel valves will not be energized, and the unit will lock out.

The Modular M-Series II controls use the same wiring base as the Fireeye UVM and TFM Controls and are designed to be interchangeable with most models without rewiring. See INSTALLATION OF CONTROL, SCANNERS, AND FLAME DETECTORS (page 5) for temperature and wiring requirements.



**NOTE:** Using MC120P chassis to upgrade UVM and TFM controls requires re-wiring the air flow switch.



## SPECIFICATIONS

### Supply:

120V (min. 102, max. 132) 50/60 Hz. (MC120/MC120R/MC120P)

230V (min. 196, max 253) 50/60Hz (MC230/MC230R)

**Table 1: AMBIENT TEMPERATURE LIMITS**

	MAXIMUM		MINIMUM	
Control	125°F	(52°C)	- 40°F	(- 40°C)
Scanner UV1A, UV2, UV8A, 45UV3	200°F	(93°C)	- 40°F	(- 40°C)
Flame Rod (Tip 2460 F)	1500°F	(816°C)	- 40°F	(- 40°C)

**Power Consumption:** 12 VA (Operating)

**Shipping Weight (Approx.):** 3 lbs. (1.4kg)

**Table 2: LOAD RATINGS**

Fireye Terminal	Typical Load	Maximum Rating & 120V 60 Hz
3 or 4 Individual or combined	Pilot valve(s) Solenoid valve Ignition Transformer	125 VA pilot duty (solenoid valve) plus 250 VA (Transformer)
5	Main Fuel Valve(s)	125 VA pilot duty (solenoid) or 25 VA pilot duty (solenoid) and 400 VA (opening) motorized
8	Motor or contactor	Motor normally energized and de-energized by the operating control whose rating must be suitable. Terminal 8 rated to de-energize 9.8 FLA, 58.8 LRA, on safety lockout.
A	Alarm	50 VA, pilot duty
Minimum load requirement = 100mA		

## APPROVALS

**Underwriters Laboratories Inc.**  
Listed Guide MCCZ - File MP 1537

**Factory Mutual System (FM) Approved**

**Underwriters Laboratories Inc.**  
Recognized Components Guide MCCZ2  
File MP1537

Approvals do not apply to MC230 and MC230R Chassis and associated programmers.

# OUTLINE DIMENSIONS

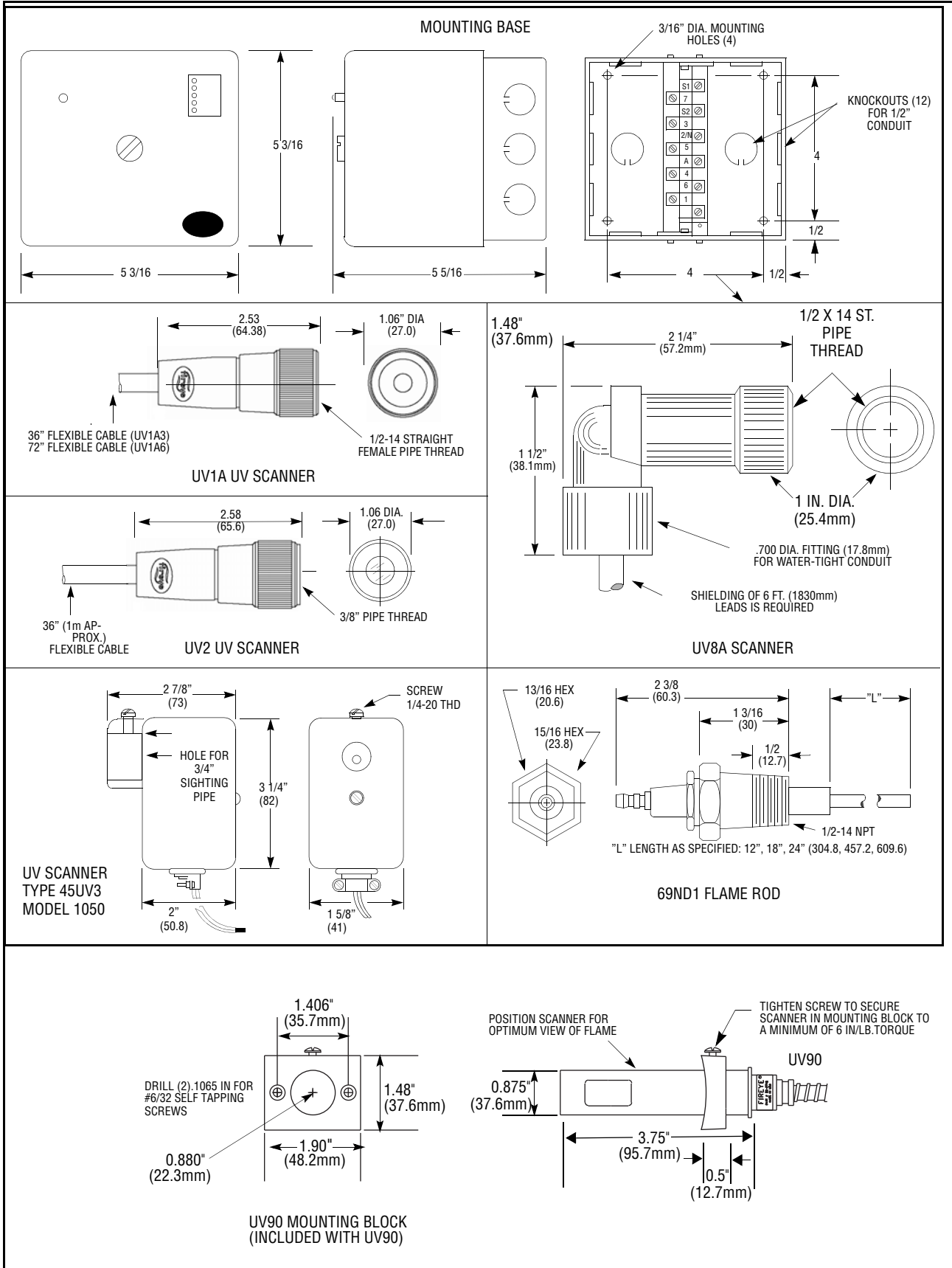



---

## ORDERING INFORMATION

### CHASSIS (COMMON FOR ALL CONTROLS, INCLUDES DUST COVER):

MC120	120 VAC Supply, 50 Hz/60 Hz
MC120R	120 VAC Supply, 50 Hz/60 Hz. Remote reset capability.
MC120P	120 VAC Supply, 50 Hz/60 Hz. Remote reset and post purge capability.
MC230	230 VAC Supply, 50 Hz/60 Hz
MC230R	230 VAC Supply, 50 Hz/60Hz. Remote reset capability.

### PROGRAMMER MODULES:

MP100, MP100E	Relight operation.
MP101	Relight operation. Programmer will not lockout on flame signal during "off cycle."
MP102, MP102E	Non-recycle on flame fail, 5 second PTFI.
MP230	Selectable purge timing, trial for ignition timing, and recycle/non-recycle operation.
MP230H	Selectable purge timing, trial for ignition timing, pilot stabilizing period, and recycle/non-recycle operation. For use with two stage burners.
MP560	Selectable purge timing, pilot trial for ignition timing, pilot stabilizing period, and recycle/non-recycle operation. 10 second main flame trial for ignition, run-check switch.
MP561	MP560 programmer without pilot stabilization period.
MP562	MP560 programmer with lockout on loss of air flow. Non-recycle operation only.

*NOTE: Programmers with the suffix "E" (e.g. MP100E) are for use with the MC230 and MC230R chassis only.*

### AMPLIFIER MODULES:USE WITH SCANNERS:

MAUV1	UV amplifier, 2-4 second F.F.R.T.	UV1A, UV2, UV8A, 45UV3-1050
MAUV1T	UV amplifier, .8 second F.F.R.T.	UV1A, UV2, UV8A, 45UV3-1050
MART1	Flame rectification amplifier, 2-4 second F.F.R.T.	69ND1
MART1T	Flame rectification amplifier, .8 second F.F.R.T.	69ND1

### UV SCANNERS:

UV1A3	1/2" NPT connector, 3' TC-ER cable
UV1A6	1/2" NPT connector, 6' TC-ER cable
UV2	3/8" NPT connector, 3' TC-ER cable
UV8A	1/2" NPT 90 degree angle head, 6' no armored flex
45UV3-1050	3/4" sleeve/setscrew mount
UV90-3	90° lateral view with 36" flex conduit
UV90-6	90° lateral view with 72" flex conduit
UV90-9	90° lateral view with 108" flex conduit

### FLAME DETECTORS:

69ND1-1000K4	12 inch flame rod, 1/2" NPT connector
69ND1-1000K6	18 inch flame rod, 1/2" NPT connector
69ND1-1000K8	24 inch flame rod, 1/2" NPT connector

**WIRING BASE (COMMON FOR ALL CONTROLS):**

- 61-3060                      Closed wiring base, surface mounting
- 61-5042                      Open wiring base, cabinet mounting

For a complete system, choose one of each of the following:

- Chassis    — UV Scanner or Flame Rod
- Programmer Module                            — Wiring Base
- Amplifier Module

 **WARNING: Installer must be trained and qualified. Follow the burner manufacturer’s instructions, if supplied. Otherwise, proceed as follows:**

**INSTALLATION OF CONTROL, SCANNERS, AND FLAME DETECTORS**

**Wiring Base**

Mount the wiring base on the burner or on a panel. The location should be free from excessive vibration and within the specified ambient temperature rating. The base may be mounted in any angular position.

All wiring should comply with applicable electrical codes, regulations, and local ordinances. Use moisture resistant wire suitable for at least 90 degrees C. Circuit recommendations are found on pages 26 through 30. Consult the factory for assistance with non-standard applications.

 **WARNING: Controls require safety limits utilizing isolated mechanical contacts. Solid state limit switches are not acceptable and should not be used due to their high leakage currents.**

**Installing the Programmer and Amplifier Modules**

 **WARNING: Remove power from the control before proceeding.**

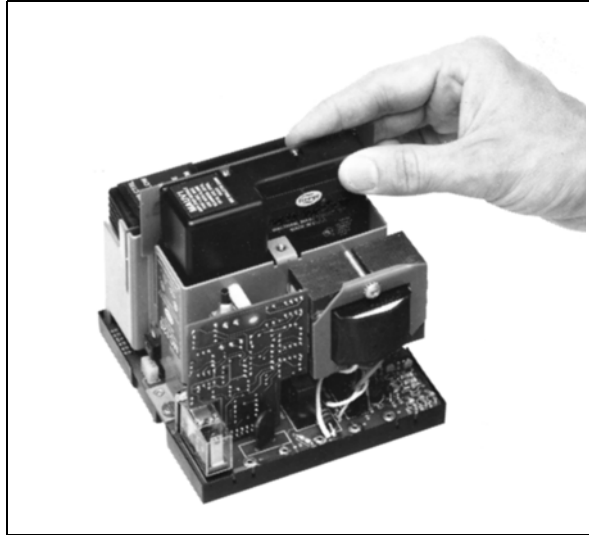

AMPLIFIER

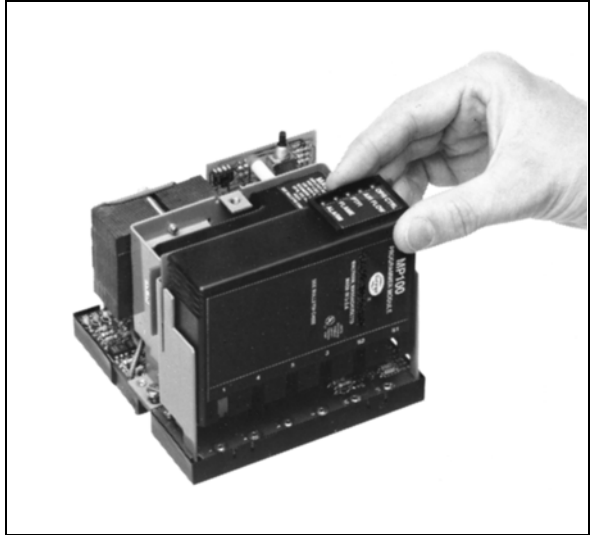

PROGRAMMER

Select the appropriate programmer and amplifier modules for your application. Remove the dust cover from the chassis. Insert the amplifier module into the slot in the center of the chassis and gently push the module into position. Insert the programmer module into the slot at the right side of the chassis and gently push the module into position.

***NOTE:** Refer to Programmer dipswitch settings on page 11 for the proper setting of the dipswitches for those programmers with this feature.*

 **WARNING: Turn off the power when installing or removing the control.**



### Replaceable Fuse

The programmer modules are designed with a field replaceable fuse. The fuse is located on the printed circuit board below the cover. The fuse will blow as a result of an overload condition on Terminals 3, 4 or 5. To replace the fuse, remove power from the system. Remove the programmer module and using a small screwdriver or similar tool, remove the fuse from its holder. Install a Fireeye replacement fuse (P/N 23-176) or equivalent 8 amp fuse (e.g. Littlefuse 225008P, 2AG, 8 amp, 125V). FOR MP100E OR MP102E, ORDER FIREYE REPLACEMENT FUSE (P/N 23-183 OR EQUIVALENT 3.5 AMP FUSE (E.G. LITTLEFUSE 22903.5, 3.5 AMP, 250V).



**WARNING: Remove power from the control before proceeding.**

## INSTALLATION - UV SCANNERS

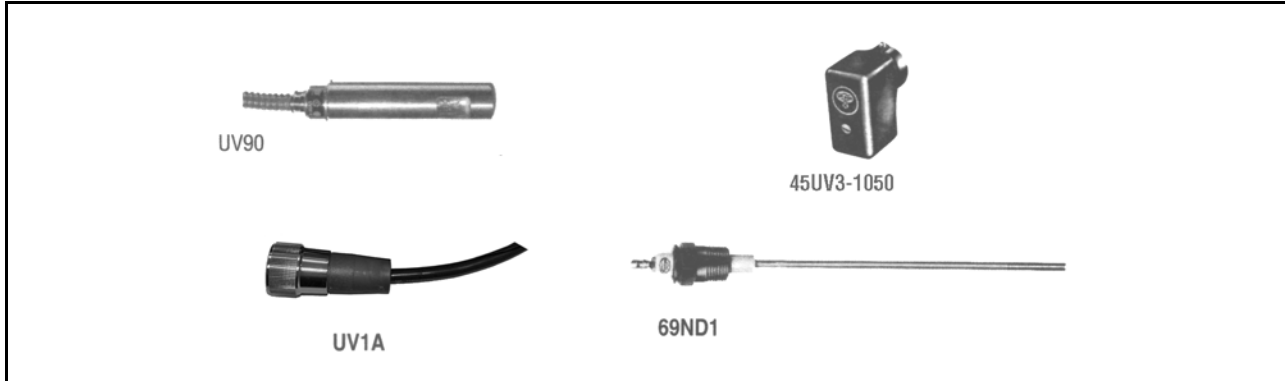

Where possible, obtain the burner manufacturer's instructions for mounting the scanner. This information is available for most standard burners. The scanner mounting should comply with the following general instructions:

1. Locate the scanner within 30 inches of the flame to be monitored, closer if possible.
2. Select a scanner location that will remain within the ambient temperature limits of the UV-eye scanner (200°F/93°C). If cooling is required, use (a) an insulating coupling (Fireeye P/N 35-69) to reduce conducted heat; (b) a window coupling (Fireeye P/N 60-1257) to seal off furnace or burner pressure; (c) cooling air to reduce the scanner sight pipe temperature.
3. Mount rigidly a short length (4" to 8") of  $\frac{1}{2}$ " or  $\frac{3}{4}$ " black iron pipe in a position that permits an unobstructed view of the pilot and/or main flame.



**CAUTION: The scanner must not sight the ignition spark directly, or any part of the burner that can reflect the spark back to the scanner.**

4. The maximum UV signal from a flame is found in the first one-third of the visible flame taken from the point where the flame begins. The scanner sight pipe should be aimed at this area.
5. A correct scanner application will not see a pilot flame that is too small to ignite the main flame reliably. Note particularly the test for minimum pilot that is described on page 22.
6. On installations having negative pressure combustion chambers, a small hole ( $\frac{1}{8}$ " or  $\frac{3}{16}$ ") drilled in the sight pipe will assist in keeping the pipe clean and free from smoke.
7. Two scanners may be installed on one burner if it is necessary to view two areas to obtain reliable detection of the flame. They should be wired in parallel.
8. The UV-eye scanner is designed to seal off the sight pipe up to pressures of 1 PSI when the scanner lock nut is firmly tightened. Pressures in excess of 1 PSI should be blocked from the scanner. A quartz lens coupling (P/N 60-1290) or quartz window coupling (P/N 60-1257) may be used. Each is rated from -3 to +100 PSI max.
9. To increase scanner sensitivity, a quartz lens coupling (P/N 60-1290) may be used. The quartz lens permits location of the UV-eye twice the distance noted in Item 1. Use  $\frac{1}{2}$ " x  $1\frac{1}{2}$ " nipple between UV1A scanner and union. Use  $\frac{3}{8}$ " close nipple and  $\frac{1}{2}$ " by  $\frac{3}{8}$ " bushing on UV-2 applications.

### General Requirements

1. As close as possible — 30" or closer.
2. As cool as possible — Not over 200°F (93°C).
3. Avoid sighting the spark — Resight scanner, shield between spark and scanner, or orifice to reduce reflected signal from spark.
4. Must see pilot and/or main flame — Scanner view must be unobstructed,
5. Minimum pilot test — See page 22.

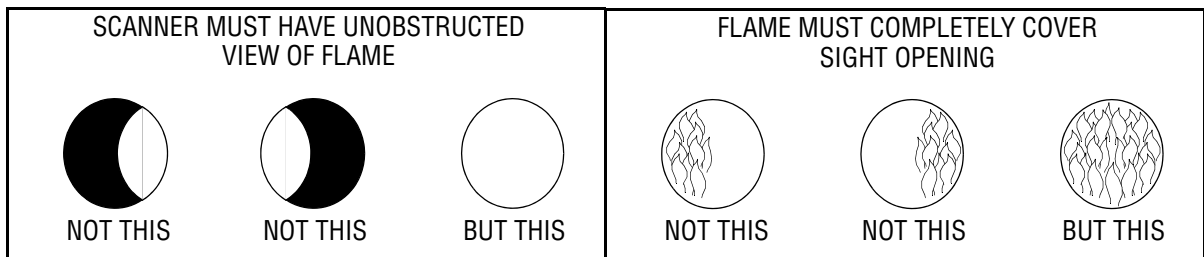

### Typical Scanner Installations

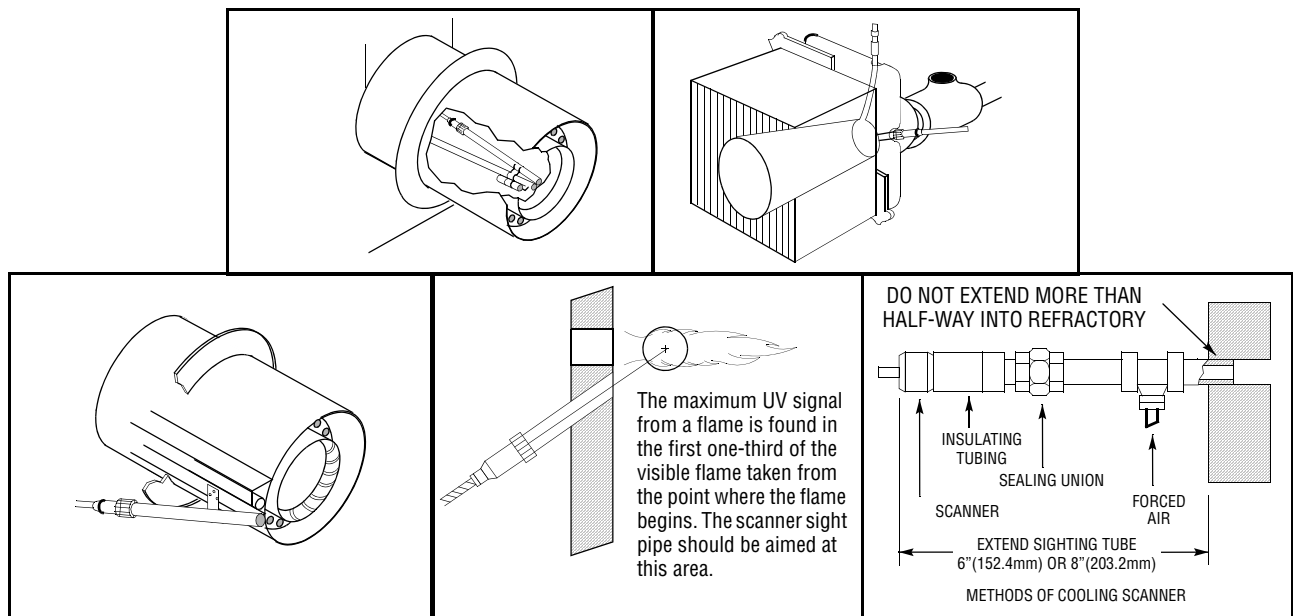

### Wiring of UV Scanners

The UV1A scanner is supplied with 36" or 72" of flexible cable. The UV-2 scanner is supplied with 36" of flexible cable. If it is necessary to extend the scanner leads, the following instructions apply:

1. Scanners without armored cable must be wired using metal cable or rigid conduit.
2. High voltage wiring must not be installed in the same conduit with flame detector wiring.
3. **Selection of Scanner Wire:**
  - a. Use #14, 16, or 18 gauge wire with 90°C, 600 volt insulation for up to 200 feet of distance. (approx. 20% signal loss at 100 feet, 40% signal loss at 200 feet).
  - b. Asbestos insulated wire should not be used.
  - c. Multi-conductor cable is not recommended without prior factory approval.
  - d. High voltage ignition wiring *should not* be installed in the same conduit with flame detector wires.

**4. Installation of Extended Scanner Wiring:**

- For extended scanner wiring up to 500 feet, and for shorter lengths to reduce signal loss, use a shielded wire (Belden 8254-RG62 coaxial cable, or equal) **for each scanner wire** of UV1, UV2. The ends of the shielding must be taped and not grounded.

**5. Multiple Scanner Installations:**

- The wiring from multiple UV scanners may be installed in a common metallic conduit.
- Multi-conductor cable is not recommended without prior factory approval.

**INSTALLATION - 69ND1 FLAME ROD**

The 69ND1 flame rod proves a gas pilot flame and/or main gas flame. It is a *spark plug* type unit consisting of  $\frac{1}{2}$ " NPT mount, a KANTHAL flame rod, a glazed porcelain insulating rod holder and a spark plug connector for making electrical connections. The 69ND1 is available in 12," 18" or 24" lengths.

The flame rod may be located to monitor only the gas pilot flame or both the gas pilot and main gas flames. It is mounted on a  $\frac{1}{2}$ " NPT coupling.

The following instructions should be observed:

1. Keep flame rod as short as possible.
2. Keep flame rod at least  $\frac{1}{2}$ " from any refractory.
3. Flame rod should enter the pilot flame from the side so as to safely prove an adequate pilot flame under all draft conditions.
4. If the flame is nonluminous (air and gas mixed before burning), the electrode tip should extend at least  $\frac{1}{2}$ " into the flame, but not more than halfway through.

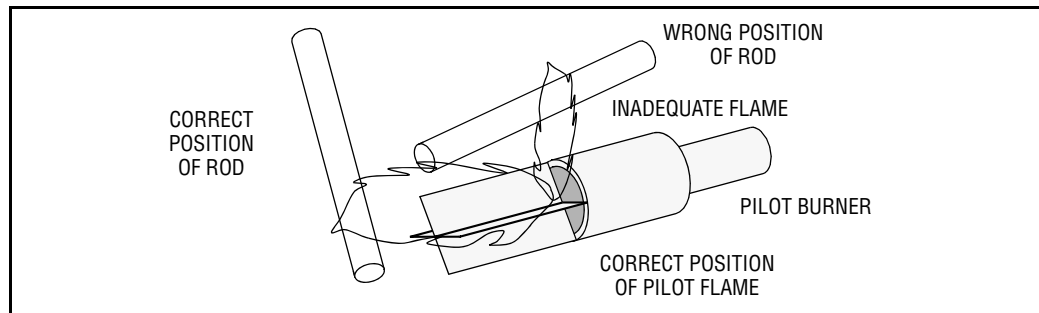

5. If the flame is partly luminous, the electrode tip should extend only to the edge of the flame. It is not necessary to maintain absolutely uninterrupted contact with the flame.
6. It is preferable to angle the rod downward to minimize the effect of sagging and to prevent it from coming in contact with any object.
7. An adequate grounding surface for the flame must be provided. The grounding surface in actual contact with the flame must be at least four times greater than the area of the portion of the flame rod in contact with the flame. It is essential to adjust the flame rod and ground area ratio to provide a minimum signal reading of 6.0 VDC.

*Note: Interference from the ignition spark can alter the true signal reading by adding to, or subtracting from it. This trend sometimes may be reversed by interchanging the primary wires (line voltage) to the ignition transformer. This interference can also be reduced by the addition of grounded shielding between the flame rod and ignition spark.*



8. Proven types of flame grounding adapters, as shown below, may be used to provide adequate grounding surface. High temperature stainless steel should be used to minimize the effect of metal oxidation. This assembly may be welded directly over the pilot or main burner nozzle.

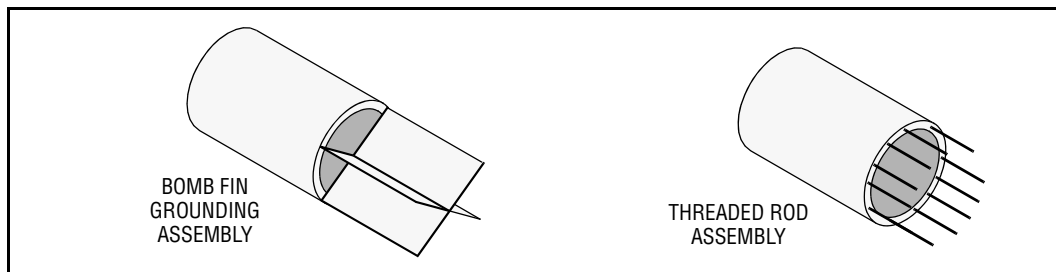

## WIRING OF FLAME RODS

For proper operation of flame rectification systems, it is necessary to maintain at least 20 megohms insulating resistance in the flame rectification circuit.

1. The scanner should be wired using metal cable or rigid conduit.
2. High voltage wiring must not be installed in the same conduit with scanner wiring.

### Selection of Scanner Wire

1. Use #14, 16, or 18 gauge wire with 90 C, 600 volt insulation for up to 20 feet distance.
2. The type of insulation used with flame rectification is important, since it must protect against current leakage resistance to ground. Use Belden 8254-RG62 Coaxial Cable (or equal) for runs greater than 20 feet. **Maximum wiring run not to exceed 100 feet.**

## MAINTENANCE

### Type UV1, UV2, UV8A, and 45UV3 Ultraviolet Scanners

The viewing area of the scanner must be kept clean. Even a small amount of contamination will reduce the flame signal reaching the detector by a measurable amount. Wipe the viewing area routinely using a soft cloth dampened with concentrated detergent.

### Type 69ND1 Flame Rod

The flame rod and its insulator should be kept clean by washing routinely with soap and water. Rods should be routinely replaced as they oxidize.

### Flame Signal Strength

Routine observation of the flame signal strength will forewarn any deterioration in the capability of the flame detector or its application.

### Periodic Safety Check

It is recommended that a procedure be established to test the complete flame safeguard system at least once a month. This test should verify the proper operation of all limit switches and safety interlocks as well as flame failure protection and fuel safety shutoff valve tightness.

### Rotation

It is recommended that control and scanner units purchased as spares be installed periodically.



## MC120P POST PURGE CHASSIS

The MC120P Chassis provides the following capabilities:

- A fifteen (15) second post purge at the end of an operating cycle or after a safety shutdown condition (prior to initiating a lockout).
- Remote reset in the event of a lockout condition.

**Fifteen (15) second post purge** — The blower motor (terminal 8) remains energized for at least 15 seconds at the end of every operating cycle (power removed from terminal 7). The blower motor also remains energized for 15 seconds following a condition which causes a safety shutdown (de-energizing terminals 3, 4, and 5). After the 15 second post purge is completed, the MC120P will initiate the safety lockout - energizing the alarm relay (lockout pushbutton) and terminal A.

*Note: Refer to Figures 6, 7, 8 and 9 on pages 29 and 30 for wiring the MC120P chassis. The air flow switch is wired between terminals 7 and 6. On the MC120, MC120R, MC230, and MC230R, the air flow switch is wired between terminals 8 and 6.*

**Remote Reset** - The MC120P chassis provides remote reset capability of a safety lockout. Refer to “Remote Reset Chassis (MC120R, MC230R, MC120P) for an explanation of the wiring and operation of the remote reset function.

## REMOTE RESET CHASSIS (MC120R, MC120P, MC230R)

The MC120R/MC120P/MC230R Chassis provides remote reset capabilities in the event of a lockout condition. A blue slide switch located on the chassis (on the same PC board as the built-in reset switch) determines the method of reset. The MC120R and MC230R can be reset in any of the following ways:

1. Depress and release the reset button built into the MC120R/MC120P/MC230R chassis. This reset button will always reset the control, regardless of the position of the blue slide switch.
2. To reset the control via a remote pushbutton, move the blue slide switch towards the wiring base. Wire a momentary dry contact pushbutton into the two (2) terminals located on the MC120R/MC120P/MC230R chassis (on the same PC board as the built-in reset switch) and depress the button for one (1) second. The maximum distance the remote reset switch can be wired from the control is 1,000 feet (max. wire size #14).
3. To reset the control via a power interruption, move the blue slide switch away from the wiring base (towards the dust cover). Interrupt the 120 VAC (MC120R/MC120P) or 230 VAC (MC230R) line power to the MC120R/MC120P chassis for one (1) second. The lockout will be reset when power is restored.
4. To reset via power interruption, remove 120 VAC (MC120R, MC120P) or 230VAC (MC230R) line power on the indicated terminals for 1 second for the following controls:

Terminal 1    MP560, MP561, MP562 when used with any amplifier.  
MP100, MP101, MP230, MP230H when used with MAUV1 or MAUV1T amplifier modules.

Terminal 7    MP100, MP101, MP230, MP230H when used with MART1 or MART1T amplifier modules.



**CAUTION: Remote reset is recommended only on a control solely for proved ignition programming (pilot ignited burner) or a control for use only with appliances in which unburned fuel cannot accumulate and that is intended for installation in inaccessible locations such as open-flame, ceiling-suspended gas heaters.**



## PROGRAMMER DIPSWITCH SETTINGS

**NOTE: THE DIPSWITCHES ARE A ONE TIME, ONE SHOT SETTING. ONCE THE DIPSWITCHES ARE SET AND THE PLASTIC WINDOW IS MOVED OVER THE SWITCHES, THE WINDOW CANNOT BE MOVED AND THE DIPSWITCHES AND THEIR SETTINGS CANNOT BE CHANGED WITHOUT CAUSING THE CONTROL TO BECOME INOPERABLE.**

The MP230, MP230H, and the MP560, MP561, MP562 Programmer Modules have a series of 8 dipswitches which allow the user to program the purge timing, trial for ignition timing, and recycle/non-recycle operation of the control. These dipswitches are programmed only **ONCE**, before the initial operation of the control.



**THE PLASTIC WINDOW MUST BE MOVED OVER THE SWITCHES IN ORDER FOR THE PROGRAMMER TO OPERATE BEYOND PURGE.**

### Purge Timing

Dipswitches # 1 through #5 are used to select the purge timing for the control. The available timing selections are 5 seconds, 7 seconds, 30 seconds, 60 seconds, 240 seconds, and any combination of those timings. The timings for these switches are **additive**. Selecting two or more purge timing switches will result in a purge timing period equal to the sum of the switches (e.g. selecting switches # 3, and #4 will cause a purge timing of 90 second: 30 seconds plus 60 seconds). To select the timing associated with a particular switch, move the switch to the **RIGHT** (On Position).

**NOTE: If all 5 switches are set to the OFF position, the control will lock out after the air flow switch has been proven closed.**

### Trial for Ignition

Dipswitches #6 and #7 are used to select the trial for ignition timing for the control. The available timing selections are 5 seconds and 10 seconds only. See Figure #1. Select **ONLY ONE** of these two switches. These switches **ARE NOT** additive. To select the timing associated with a particular switch, move the switch to the **RIGHT** (On Position).

**NOTE: If both switches are set to the OFF position, the control will default to a trial for ignition period less than 5 seconds (e.g.: 3-4 seconds).**

If both switches are set to the **ON** position, the control will default to **LOCKOUT**.

### Recycle/Non-recycle Operation

Dipswitch #8 is used to select either recycle or non-recycle operation of the control. (See APPLICATION AND FUNCTION). To select **RECYCLE** operation, move the switch to the **LEFT**. To select **NON-RECYCLE** operation, move the switch to the **RIGHT**.

SWITCH	OFF	ON	
1	-	5	PURGE TIMING *
2	-	7	
3	-	30	
4	-	60	
5	-	240	
6	-	5	PTFI
7	-	10	
8	RECYCLE	NON RECYCLE	

\* The MP561 programmer module has purge timing selctions of 5, 7, 15, 30 and 60 seconds.



---

### Setting the Switches

Once the appropriate switches are set, slide the clear plastic window to the left so that it covers the switches and LOCKS into place. This action causes the control to become operable with the settings programmed from the dipswitches. The plastic window CANNOT be moved, and the dipswitches and their settings CANNOT be changed without causing the control to become inoperable. If the control does require alternative timings, the programmer module will have to be removed and replaced with another module with the appropriate dipswitch settings.

---

## LED INDICATOR LIGHTS

The MP100, MP230, MP230H, and the MP560 Programmer Modules have 5 LED lights to indicate the operating status of the control. The function of these lights are:

**Operating Control:** This LED is energized whenever the burner control switch (Terminal #7) along with the various limit switches, operating controls and fuel interlocks are closed.

**Air Flow:** This LED is energized whenever power is detected between Terminals #8 and #6, indicating the air flow switch has closed.

**PTFI:** This LED is energized only during the Pilot Trial For Ignition Period.

**Flame On:** This LED is energized whenever a flame signal is detected by the UV scanner or Flame detector.

**Alarm:** this LED is energized whenever a safety lockout occurs. (See APPLICATION AND FUNCTION section).

---

## APPLICATION AND FUNCTION - MP100, MP100E

The MP100 and MP100E Programmer Modules are designed as a replacement for the Fireeye M1 Series "relight" controls. It provides ignition and Flame Safeguard for heating or process light oil or gas fired burners. The Amplifier Module should be selected based on the type of flame scanner (UV scanner or flame rod), and the required Flame Failure response Time (F.F.R.T.). See ORDERING INFORMATION on page 4 for the appropriate part numbers.

### Pilot Ignited Burners

The typical wiring arrangement illustrated on pages 26 (MC120, MC230) or 29 (MC120P) for pilot ignited burners provides the following function:

1. With power applied, and the limit-operating control circuit closed (**Operating Control LED** lit), the burner motor circuit is energized. The air flow switch circuit closes (**Air Flow LED** lit).
2. Following a short-time delay (4 to 6sec.), KL-1 closes, energizing Terminal 3 which powers the pilot gas valve, and Terminal 4 which powers the spark ignition. A 10 sec. trial for ignition is initiated (**PTFI LED** lit).
3. When pilot flame is detected (**Flame LED** lit), KF-1 closes, energizing Terminal 5 which powers the main fuel valve, and KF-2 opens, de-energizing Terminal 4 which shuts off the spark ignition.
4. When the operating control opens its circuit, or if a power failure occurs, the control is de-energized. Power interruptions in the millisecond range do not affect the operation of the control. Power interruptions of longer duration will cause the control to recycle.

**NOTE:** Controls with UV amplifiers (MAUV1 and MAUVIT) are always powered via Terminal #1.

5. In the event the pilot flame is not detected by the end of the trial for ignition period, the pilot gas valve and spark ignition are de-energized. A safety lockout occurs which de-energizes the burner motor and energizes the lockout alarm circuit (**Alarm LED** lit) approximately 30 seconds after the safety lockout occurs.



6. In the event of a flame failure during a firing period, the main fuel valve is de-energized and the spark ignition re-energized. A 10 sec. relight trial for ignition is initiated (**PTFI LED lit**). If flame is detected (**Flame LED lit**) during the trial for ignition period, the main fuel valve is re-energized and the spark ignition de-energized. If flame is not detected during the trial for ignition period, the pilot gas valve and spark ignition are de-energized. A safety lockout occurs which de-energizes the burner motor and energizes the lockout alarm circuit (**Alarm LED lit**) approximately 30 seconds after the safety lockout occurs.

7. **Manual reset is required following any safety lockout.**

*NOTE: Wait 10 seconds after lockout before resetting the control.*

### **Direct Spark Ignited Burners**

The typical wiring arrangement illustrated on pages 26 (MC120, MC230 or 29 (MC120P) for direct spark ignited burners provides the following function:

1. With power applied, and the limit-operating control circuit closed (**Operating Control LED lit**), the burner motor circuit is energized. The air flow switch circuit closes (**Air Flow LED lit**).
2. Following a short-time delay (4-6 sec.) KL-1 closes, energizing Terminal 3 which powers the primary main fuel valve and Terminal 4 which powers the spark ignition. A ten sec. trial for ignition is initiated (**PTFI LED lit**).
3. When main flame is detected (**Flame LED lit**), KF-1 closes, energizing Terminal 5 which powers the secondary main fuel valve (if used), KF-2 opens de-energizing Terminal 4 which shuts off the spark ignition.
4. When the operating control opens or if a power failure occurs, the control is de-energized. Power interruptions in the millisecond range do not affect the operation of the control. Power interruptions of longer duration will cause the control to recycle.

*NOTE: Controls with UV amplifiers (MAUV1 and MAUVIT) are always powered via Terminal #1.*

5. In the event that main flame is not detected by the end of the trial for ignition period, the primary main fuel valve and the spark ignition are de-energized. A safety lockout occurs which de-energizes the burner motor and energizes the lockout alarm circuit (**Alarm LED lit**) approximately 30 seconds after the safety lockout occurs.
6. In the event of a flame failure during a firing period, the secondary main fuel valve (if used) is de-energized and the spark ignition is re-energized. A 10 sec. re-light trial for ignition is initiated (**PTFI LED lit**). If flame is detected (**Flame LED lit**), the secondary main fuel valve (if used) is re-energized and the spark ignition de-energized. If flame is not detected during the trial for ignition period, the primary main fuel valve and the spark ignition are de-energized. A safety lockout occurs, which de-energizes the burner motor and energizes the lockout alarm circuit (**Alarm LED lit**) approximately 30 seconds after the safety lockout occurs.
7. **Manual reset is required following and safety lockout.**

*NOTE: Wait 10 seconds after lockout before resetting the control.*

### **Standing Pilot Burners**

When using an MP100 or MP100E with an MARTI or MARTIT amplifier to control a burner having a standing pilot, clip out the red wire loop close to the edge of the circuit board. This eliminates pilot proving when the main burner is off and requires pilot flame proving during the subsequent start-up.

## TIMING CHART

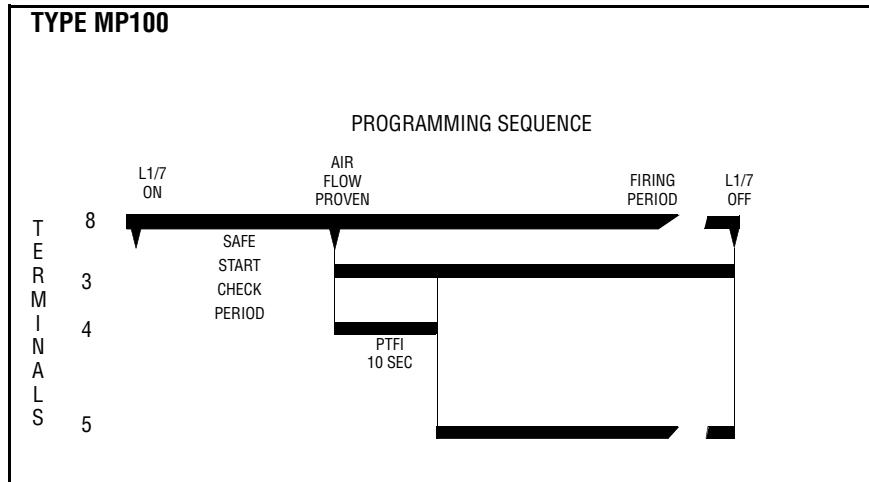

Re-ignited PTFI on flame fail after Terminal 5 energized.

Recycle on loss of air flow after flame proven.

### MP101

Same as MP100 but will tolerate flame signal during "Off" cycle.

## APPLICATION AND FUNCTION - MP101

The MP101 operates in the same manner as the MP100 with the following exception. The MP101 programmer module will not lock out if flame signal is detected during the off cycle (no power on terminal 7). If flame signal is present when power is applied to terminal 7, the control will not lock out until the air flow switch is proven closed (power on terminal 6).

Consult the factory before installing the programmer.

## APPLICATION AND FUNCTION MP230

The MP230 Programmer Module directly replaces the Fireye M2 Series "recycle" controls and M3 Series "non-recycle" controls. It provides prepurge, ignition and flame safeguard for heating and process light oil or gas fired burners. The "recycle" or "non-recycle" operation is determined by the position of dipswitch #8 on the Programmer Module. Purge timing, as well as trial for ignition timing is also set by the dipswitch settings. See PROGRAMMER DIP-SWITCH SETTINGS on page 11.

### Amplifier and Scanner Selection

The Amplifier Module should be selected base on the type of flame scanner (UV scanner or flame rod), and the required Flame Failure Response Time (F.F.R.T.). See ORDERING INFORMATION on page 4 for the appropriate part numbers.

### Pilot Ignited Burners - "Recycle" Operation

With dipswitch #8 in the "recycle" position, the typical wiring arrangement illustrated on pages 26 (MC120, MC230) or 28 (MC120P) for pilot ignited burners provides the following function:

1. With power applied, and the limit-operating control circuit closed (**Operating Control LED** lit), the burner motor circuit is energized. The air flow circuit closes (**Air Flow LED** lit).
2. Following the prepurge period (as determined by dipswitches #1 through #5), KL-1 closes, energizing Terminal 3 which powers the pilot gas valve and Terminal 4 which powers the spark ignition. A five or ten sec. (as determined by dipswitches #6 or #7) trial for ignition is initiated (**PTFI LED** lit).
3. When pilot flame is detected (**Flame LED** lit), KF-1 closes, energizing Terminal 5 which powers the main fuel valve, KF-2 opens de-energizing Terminal 4 which shuts off the spark ignition.



4. When the operating control opens its circuit, or if a power failure occurs, the entire system is de-energized. Power interruptions in the millisecond range do not affect the operation of the control. Power interruptions of longer duration will cause the control to recycle.

*NOTE: Controls with UV amplifiers (MAUV1 and MAUVIT) are always powered via Terminal #1.*

5. In the event the pilot flame is not detected by the end of trial for ignition period, the pilot gas valve and spark ignition are de-energized. A safety lockout occurs which de-energizes the burner motor and energizes the lockout alarm circuit (**Alarm** LED lit) approximately 30 seconds after the safety lockout occurs.
6. In the event of a flame failure during a firing period, the pilot and main fuel valves are de-energized. Following the prepurge period (as determined by dipswitches #1 through #5), with proven air flow (**Air Flow** LED lit), the pilot gas valve and spark ignition are re-energized and a five or ten sec. (as determined by dipswitches #6 or #7) trial for ignition is initiated (**PTFI** LED lit). If pilot flame is detected (**Flame** LED lit), the main fuel valve is energized, the spark ignition is de-energized. If the pilot flame is not detected during the trial for ignition period, the pilot gas valve and spark ignition are de-energized. A safety lockout occurs which de-energizes the burner motor and energizes the lockout alarm circuit (**Alarm** LED lit) approximately 30 seconds after the safety lockout occurs.
7. Manual reset is required following any safety lockout.

*NOTE: Wait 10 seconds after lockout before resetting the control.*

#### **Pilot Ignited Burners - “Non-recycle” Operation**

The function of “non-recycle” pilot ignited burners is the same as described for the “recycle” controls, except that the “non-recycle” operation will lock out following any flame failure. “Recycle” or “non-recycle” operation is determined by the position of dipswitch #8. See Programmer dipswitch settings on page 11.

#### **Direct Spark Ignited Burners - “Recycle” Operation**

With dipswitch #8 in the “recycle” position, the typical wiring arrangement illustrated on pages 26 (MC120, MC230) or 28 (MC120P) for direct spark ignited burners provides the following function:

1. With power applied, and the limit-operating control circuit closed (**Operating Control** LED lit), the burner motor circuit is energized. The air flow switch circuit closes (**Air Flow** LED lit).
2. Following the selected prepurge period (as determined by dipswitches #1 through #5), KL-1 closes, energizing Terminal 3 which powers the primary main fuel valve, and Terminal 4 which powers the spark ignition. A five or ten second (as determined by dipswitches #6 and #7) trial for ignition is initiated (**PTFI** LED lit).
3. When pilot flame is detected (**Flame** LED lit), KF-1 closes, energizing Terminal 5 which powers the secondary main fuel valve, and KF-2 opens, de-energizing Terminal 4 which shuts off the spark ignition.
4. When the operating control opens its circuit, or if a power failure occurs, the control is de-energized. Power interruptions in the millisecond range do not affect the operation of the control. Power interruptions at longer duration will cause the control to recycle.

*NOTE: Controls with UV amplifiers (MAUV1 and MAUVIT) are always powered via Terminal #1.*

5. In the event the pilot flame is not detected by the end of the trial for ignition period, the pilot gas valve and spark ignition are de-energized. A safety lockout occurs which de-energizes the burner motor and energizes the lockout alarm circuit (**Alarm** LED lit) approximately 30 seconds after the safety lockout occurs.



6. In the event of a flame failure during a firing period, all fuel valves are de-energized. Following the prepurge period (as determined by dipswitches #1 through #5), with proven air flow (**Air Flow LED** lit), the primary main fuel valve and spark ignition are re-energized and a five or ten second (as determined by dipswitches #6 and #7) trial for ignition period is initiated (**PTFI LED** lit). If flame is detected (**Flame LED** lit), the secondary main fuel valve (if used) is energized. The spark ignition is de-energized. If flame is not detected during the trial for ignition period, the primary main fuel valve and spark ignition are de-energized. A safety lockout occurs, de-energizing the burner motor and energizing the lockout alarm circuit (**Alarm LED** lit) approximately 30 seconds after the safety lockout occurs.
7. Manual reset is required following any safety lockout.

*NOTE: Wait 10 seconds after lockout before resetting the control.*

### Direct Spark Ignited Burners - “Non-recycle” Operation

The function of “non-recycle” direct spark ignited burners is the same as described for the “recycle” controls, except that the “non-recycle” operation will lock out following any flame failure. “Recycle” or “non-recycle” operation is determined by the position of dipswitch #8. See Programmer Dipswitch Settings on page 11.

### TIMING CHART

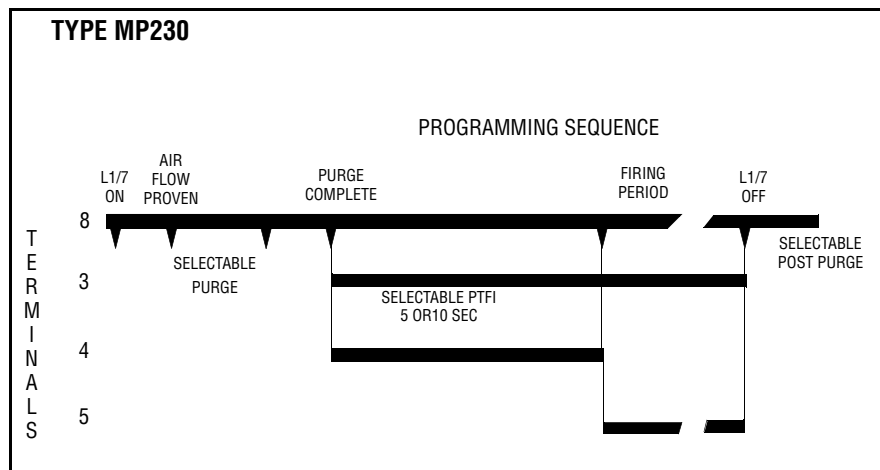

Selectable Recycle/Non-Recycle operation on loss of flame after Terminal 5 energized.  
 Recycle on loss of air flow after flame proven.



## APPLICATION AND FUNCTION - MP230H

The MP230H Programmer Module is designed as a direct replacement for the Fireye M3H Series “non-recycle” controls, as well as providing a “recycle” operation for the control. It provides pre-purge, ignition and flame safeguard for heating and process light oil or gas fired burners. The “recycle” or “non-recycle” operation is determined by the position of dipswitch #8 on the Programmer Module. Purge timing as well as trial for ignition timing is also set by the dipswitch settings. See Programmer Dipswitch Settings on page 11.

All installation, wiring, functions, testing instructions for the MP230 control are applicable to the MP230H. The MP230H provides an additional function whereby the powering of Terminal 5 is delayed for eight (8) seconds after flame is detected, and Terminal 4 remains powered during the eight (8) second delay.

This additional function is offered primarily for two-stage light oil burners, to assure a specific delay between light off of the first and second stage, and to provide additional ignition timing to improve flame stabilization.

### Amplifier and Scanner Selection

The Amplifier Module should be selected based on the type of flame scanner (UV scanner or flame rod), and the required Flame Failure response Time (F.F.R.T.). See ORDERING INFORMATION on page 4 for the appropriate part numbers.

### TIMING CHART

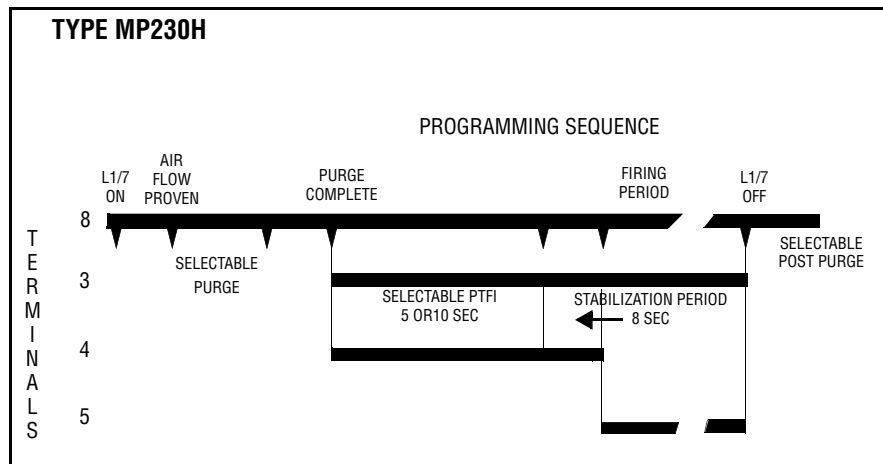

Pilot Stabilization timing begins as soon as flame is proven.

Selectable Recycle/Non-Recycle operation on loss of flame after Terminal 5 is energized.



---

## APPLICATION AND FUNCTION - MP560, MP561, MP562

The MP560, MP561, MP562 Programmer Modules are designed as a direct replacement for the Fireeye M5 Series “non-recycle” controls and M6 Series “recycle” and “non-recycle” controls. It provides prepurge, ignition and flame safeguard for heating and process light oil or gas fired burners. The “recycle” or “non-recycle” operation is determined by the position of dipswitch #8 on the Programmer Module. Purge timing as well as trial for ignition timing is also set by the dipswitch settings. See PROGRAMMER DIPSWITCH SETTING on page 11.

A “run-check” switch is provided to assist in testing size, position, and stabilization of pilot in conjunction with the flame detector. See page 28.

### Amplifier and Scanner Selection

The Amplifier Module should be selected based on the type of flame scanner (UV scanner or flame rod), and the required Flame Failure Response Time (F.F.R.T.). See ORDERING INFORMATION on page 4 for the appropriate part numbers.

### Pilot Ignited Burners - “Recycle” Operation

With dipswitch #8 in the “recycle” position, the typical wiring arrangement illustrated on pages 29 (MC120, MC230) or 30 (MC120P) for pilot ignited burners provides the following function:

1. With power applied, and the limit-operating control circuit closed (**Operating Control LED** lit), the burner motor circuit is energized. The air flow circuit closes (**Air Flow LED** lit).
2. Following the selected prepurge period (as determined by dipswitches #1 through #5), KL-1 and K1-1 close, energizing Terminals 3 and 4 which powers the pilot valve and the spark ignition. A 5 or 10 sec. (as determined by dipswitches #6 and #7) trial-for-ignition initiates (**PTFI LED** lit).
3. When pilot flame is detected (**Flame LED** lit), an 8 sec. pilot stabilization period begins followed by KF-1 closing. Ten seconds after KF-1 closes, Terminal 4 is de-energized.
4. When the operating control opens its circuit or if a power failure occurs, the control is de-energized. Power interruptions in the millisecond range do not affect the operation of the control. Power interruptions at longer duration will cause the control to recycle.

*NOTE: Controls with UV amplifiers (MAUVI and MAUVIT) are always powered via Terminal #1.*

5. In the event the pilot flame is not detected by the end of trial for ignition period, the pilot valve and spark ignition are de-energized. A safety lockout occurs which de-energizes the burner motor and energizes the lockout alarm circuit (**Alarm LED** lit) approximately 30 seconds after the safety lockout occurs.
6. In the event of a flame failure during a firing period, the pilot and main fuel valves are de-energized. Following the prepurge period (as determined by dipswitches #1 through #5), with proven air flow (**Air Flow LED** lit), the pilot valve and spark ignition are re-energized and a 5 or 10 sec. (as determined by dipswitches #6 and #7) trial-for-ignition is initiated (**PTFI LED** lit). If pilot flame is detected (**Flame LED** lit), the main fuel valve is energized, the spark ignition and pilot are de-energized. If the pilot flame is not detected during the trial for ignition period, the pilot gas valve and spark ignition are de-energized. A safety lockout occurs which de-energizes the burner motor and energizes the lockout alarm circuit (**Alarm LED** lit) approximately 30 seconds after the safety lockout occurs.
7. Manual reset is required following any safety lockout.

*NOTE: Wait 10 seconds after lockout before resetting the control.*

## TIMING CHART

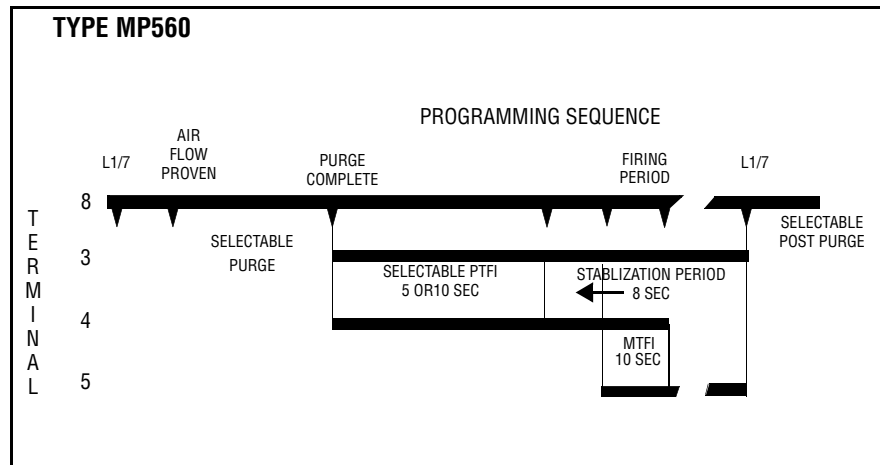

Pilot Stabilization timing begins as soon as flame is proven.

Selectable Recycle/Non-Recycle operation on loss of flame after Terminal 5 is energized.

### Pilot Ignited Burners - “Non-recycle” Operation

The function of “non-recycle” pilot ignited burners is the same as described for the “recycle” controls, except that the “non-recycle” operation will lock out following any flame failure. “Recycle” or “non-recycle” operation is determined by the position of dipswitch #8. See Programmer Dipswitch Settings on page 11.

### Direct Spark Ignited Burners - “Recycle” Operation

With dipswitch #8 in the “recycle” position, the typical wiring arrangement illustrated on page 28 (MC120, MC230) or 25 (MC120P) for direct spark ignited burners will provide the following function:

1. With power applied, and the limit-operating control circuit closed (**Operating Control LED** lit), the burner motor circuit is energized. The air flow circuit closes (**Air Flow LED** lit).
2. Following the selected prepurge period (as determined by dipswitches #1 through #5), KL-1 and K1-1 close, energizing Terminal 3 which powers the primary main fuel valve, and Terminal 4 which powers the spark ignition. A five or ten second (as determined by dipswitches #6 and #7) trial for ignition is initiated (**PTFI LED** lit).
3. When primary flame is detected (**Flame LED** lit), an 8 second stabilization period begins and KF-1 closes, energizing Terminal 5 which powers the main fuel valve. Ten seconds later K1-1 opens, de-energizing Terminal 4 which shuts off the spark ignition.
4. When the operating control opens its circuit, or if a power failure occurs, the control is de-energized. Power interruptions in the millisecond range do not affect the operation of the control. Power interruptions at longer duration will cause the control to recycle.

*NOTE: Controls with UV amplifiers (MAUV1 and MAUVIT) are always powered via Terminal #1.*

5. In the event the primary flame is not detected by the end of the trial for ignition period, the primary valve and spark ignition are de-energized. A safety lockout occurs which de-energizes the burner motor and energizes the lockout alarm circuit (**Alarm LED** lit) approximately 30 seconds after the safety lockout occurs.
6. In the event of a flame failure during a firing period, the pilot and main fuel valves are de-energized. Following the prepurge period (as determined by dipswitches #1 through #5), with proven air flow (**Air Flow LED** lit), the primary main fuel valve and spark ignition are re-energized and a 5 or 10 sec. (as determined by dipswitches #6 and #7) trial-for-ignition is initiated (**PTFI LED** lit). If flame is detected (**Flame LED** lit), the secondary main fuel valve (if used) is energized. The spark

ignition is de-energized. If flame is not detected during the trial for ignition period, the primary main fuel valve and spark ignition are de-energized. A safety lockout occurs which de-energizes the burner motor and energizes the lockout alarm circuit (**Alarm LED lit**) approximately 30 seconds after the safety lockout occurs.

- Manual reset is required following a safety lockout.

*NOTE: Wait 10 seconds after lockout before resetting the control.*

### Direct Spark Ignited Burners - "Non-recycle" Operation

The function of "non-recycle" direct spark ignited burners is the same as described for the "recycle" controls, except that the "non-recycle" operation will lock out following any flame failure. "Recycle" or "non-recycle" operation is determined by the position of dipswitch #8. See Programmer Dipswitch Settings on page 11.

## APPLICATION AND FUNCTION — MP561

The MP561 operates in the same manner as the MP560 with the following exception. The MP561 programmer does not have the 8 second pilot stabilization period. KF-1 closes as soon as flame is detected. Terminal 4 is de-energized 10 seconds later.

### TIMING CHART

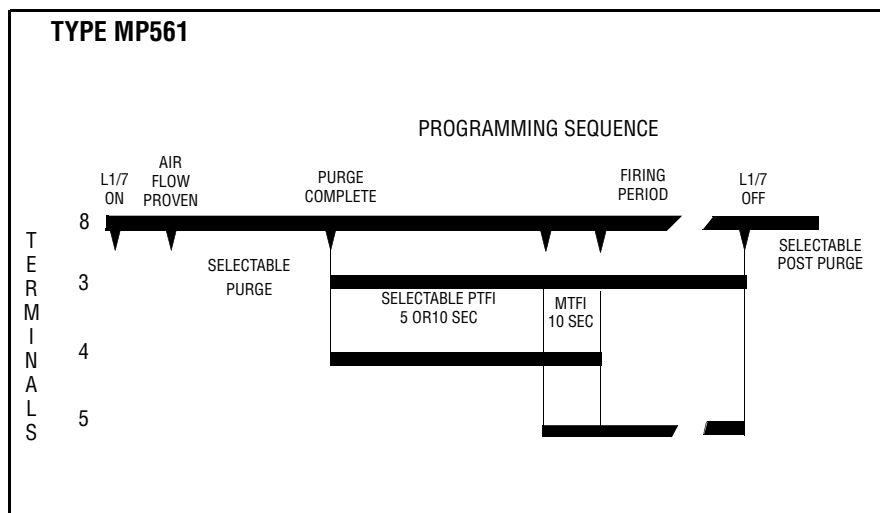

Selectable Recycle/Non-Recycle operation on loss of flame after Terminal 5 is energized.

## APPLICATION AND FUNCTION - MP562

The MP562 operates in the same manner as the MP560 programmed for "Non-Recycle Operation" with the following exceptions.

- On loss of air flow (terminals 8-6) during the purge period, the control will re-initiate the purge period once air flow is proven.
- On loss of air flow (terminals 8-6) after the purge period has been completed, the control will initiate a safety shutdown and lockout
- Dipswitch #6 is not functional on the MP562, MP562E programmers.

*Note: The control will lockout on loss of flame during the trial for ignition period or main flame.*

## TIMING CHART

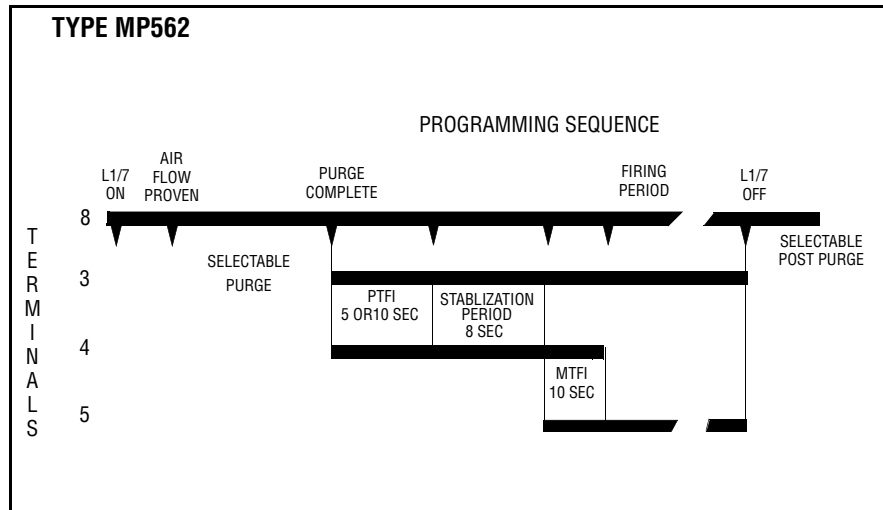

Pilot stabilization timing begins as soon as flame is proven.

Lockout on loss of air flow after flame is proven.

Lockout on flame fail.

## INSTALLATION TESTING

### Use of Test Meter (All Controls)

Testing the Fireye Modular M-Series II Controls requires the use of a test AC-DC multimeter, with a 1,000 ohm/volt DC rating or greater, or a digital meter with 500K input impedance or greater.

With the test meter on the DC scale, and the test meter leads inserted into the test jacks on the amplifier module, a **steady DC voltage reading of 4.0 to 6.0 volts (for UV amplifiers) and 6 to 18 volts (for flame rectification amplifiers)** should be obtained when the controls are detecting flame, and zero volts when no flame is present.

With the test meter on the AC scale, line and load voltages may be measured at the identified test points on the chassis.

On the Modular M-Series II controls utilizing a flame rectification amplifier, a micro-ammeter may be connected in series with the wire to Terminal S2. Normal flame will produce a meter reading between 4 and 10 micro-amperes.

### Flame Signal Testing (All Controls)

1. Manually shut off the main fuel valve for a pilot ignited burner, or the secondary fuel valve for a direct spark ignited burner.
2. Set the test meter on the DC scale and insert the test leads into the test jacks on the amplifier module. (If the meter reads backwards, reverse the meter leads). Red - Plus, Black - Negative.
3. Initiate a normal startup.
4. When flame is established, the test reading should be normal: a steady DC voltage reading of 4.0 to 6.0 volts (for UV amplifiers) and 6 to 18 volts (for flame rectification amplifiers).
5. Inadequate flame signal may be improved by:
  - a. Assuring that the flame detector and wiring installations have followed the instructions on pages 3 and 5.
  - b. Assuring that the flame detector is clean and within the ambient temperature limits.
  - c. Assuring that the flame is sufficiently large to detect.
  - d. Assuring that the flame quality (fuel to air ratio, combustion air velocity) is satisfactory.
  - e. Trying a shorter sight pipe, or increasing the sight pipe diameter.



**WARNING:** Before making a pilot flame test, manually shut off the fuel supply to the main burner.

**Normal Pilot Flame Test (MP560, MP561, MP562 Programmers Only)**

1. Place the “Run-Check” switch in the “Check” position.
2. Turn power on and initiate a normal startup.
3. Observe the pilot flame signal on the test meter. If the average flame is below normal, a steady DC voltage reading of 4.0 to 6.0 volts (for UV amplifiers) and 14 to 18 volts (for flame rectification amplifiers), re-adjust the pilot flame or realign the flame detector.



**WARNING: DO NOT TOUCH a flame rectification rod with power applied.**

4. During the pilot flame test and adjustment period, if flame is not detected within 30 seconds, the control will lock out. To reestablish the pilot flame trial for ignition (P.T.F.I.), manual reset of the lockout switch is required, and a complete repurge is accomplished.
5. When UV detection is used, a test is required to verify that UV radiation from the ignition spark is not being detected. To accomplish this, manually shut off both pilot and main fuels. Initiate a normal startup, observe the test meter which should read no more than 1/2 volt DC. If more than 1/2 volt DC is observed, realign the UV scanner, and/or shield the spark from the scanner’s view.
6. Move the “Run-Check” switch to the “Run” position, check pilot flame failure response time by manually shutting off the pilot fuel and then initiate a normal startup. With no pilot flame present, the control will de-energize the pilot assembly at the end of the trial for ignition interval (5 or 10 seconds, selected by dipswitches #6 and #7 - see Programmer Dipswitch Settings on page 11), and the control will lock out.



**WARNING: The minimum pilot test must be accomplished by a trained and qualified burner technician.**

**Minimum Pilot Test**

This test insures that the flame detector will not sense a pilot flame too small to light the main flame reliably. It must be made on every new installation as well as following the repositioning of the flame detector. **This procedure should not be used on a direct spark ignited burner.**

1. Manually shut off the fuel to the main burner.
2. Place the “Run-Check” switch in the “Check” position. (MP560 Programmers only).
3. Connect a test meter to the test jacks on the Amplifier Module.
4. Initiate a normal startup.
5. Reduce the fuel to the pilot until the DC voltmeter reads 3.5 volts for UV scanners. See WARNING below. This is the minimum pilot. For flame rectification the flame signal for minimum pilot varies depending on the application. See WARNING below.
6. Return the “Check-Run” switch to the “Run” position. (MP560 Programmer only).
7. Slowly turn on the main fuel and insure that the main flame lights off promptly and normally.



**WARNING: If light off is delayed, shut off the power to the installation. Realign the flame detector so that pilot flame detection requires a larger pilot flame. Repeat this test until the main flame lights reliably with minimum pilot.**



8. After the minimum pilot test is completed satisfactorily, increase the pilot flame to normal size, and observe that the main flame is properly established during a normal cycle (“Run-Check” switch in the “Run” position).

#### Flame Failure Test

1. Temporarily connect spark ignition and pilot valve to Terminal #3.
2. Initiate a normal startup.
3. Manually shut off all fuel and observe the loss of flame signal on the test meter.
4. If flame signal does not reduce to zero within the flame failure response time of the control (F.F.R.T. determined by selection of amplifier), verify that the UV flame detector is not actuated by the spark. If spark is detected, a metallic shield or relocation of the UV detector sight pipe is required.



5. **IMPORTANT:** When the test is completed, reconnect the spark ignition to Terminal #4.

#### Recommendation

**Periodic Safety Check:** Test the complete flame safeguard system at least once a month. This test should verify flame failure safety shutdown and positive fuel cutoff when the fuel valve is de-energized.

---

## MAINTENANCE

**UV-eye scanner:** The UV tube must be kept clean. Use a clean cloth with detergent as often as operating conditions require. Remove any residual detergent.

---

## ROTATION

It is recommended that units purchased as spares be rotated periodically, so that each unit will be placed in operation every 90 days.





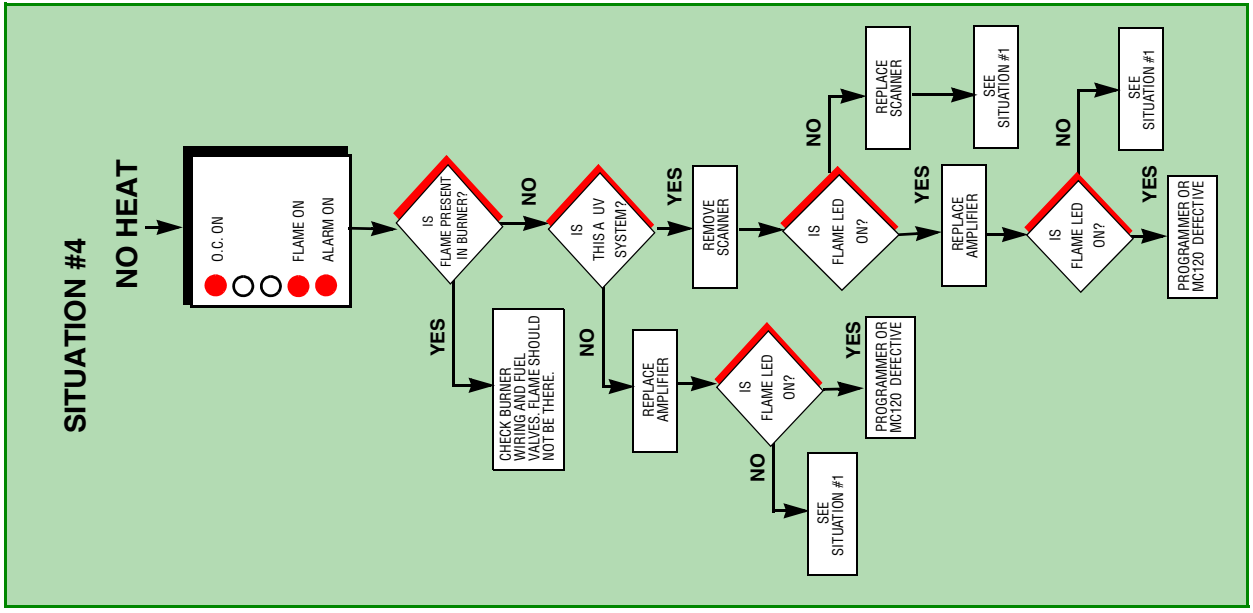
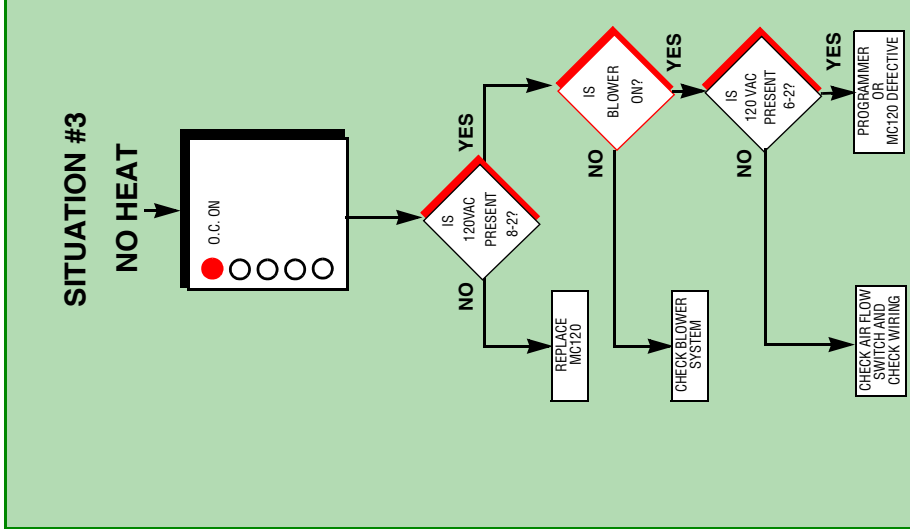
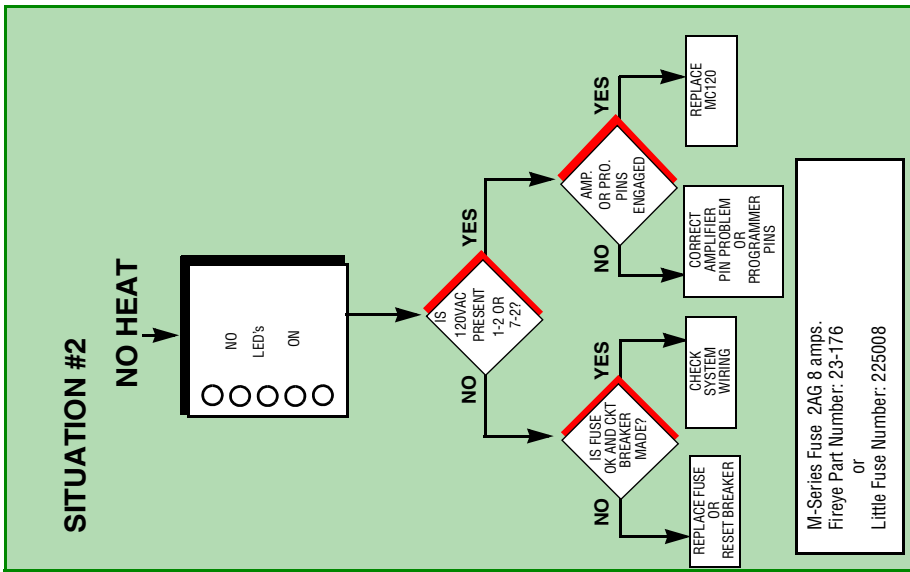

- #### TROUBLESHOOTING TIPS
1. Verify that there is a solid earth ground wire brought to the panel that the Fireye base is mounted to.
  2. In a rectification system, verify that terminal S1 is solidly earth grounded, and confirm that the flame rod is aligned so it doesn't droop near the ignition spark.
  3. Confirm that there is no measurable voltage present between the ground screw and terminal 2 (neutral).
  4. Confirm that the 120 volt AC supply has its neutral leg earth grounded at the supply, (floating isolation transformers can cause problems).
  5. Confirm that the ignition transformer's secondary winding is solidly earth grounded. The grounding method is usually through the transformer case. Dirt, paint, loose mounting hardware, etc., can all be factors.
  6. There may be a problem with transients in the main power supply. If you think this may be the problem, you may want to run a ground wire directly from the pilot assembly back to the electrical panel where the Fireye control is mounted.



**FIGURE 1.** TYPICAL MP100, MP100E, MP101, MP230, and MP230H WIRING ARRANGEMENT FOR PILOT IGNITED BURNER. **MC120, MC120R, MC230, MC230R CHASSIS ONLY.**

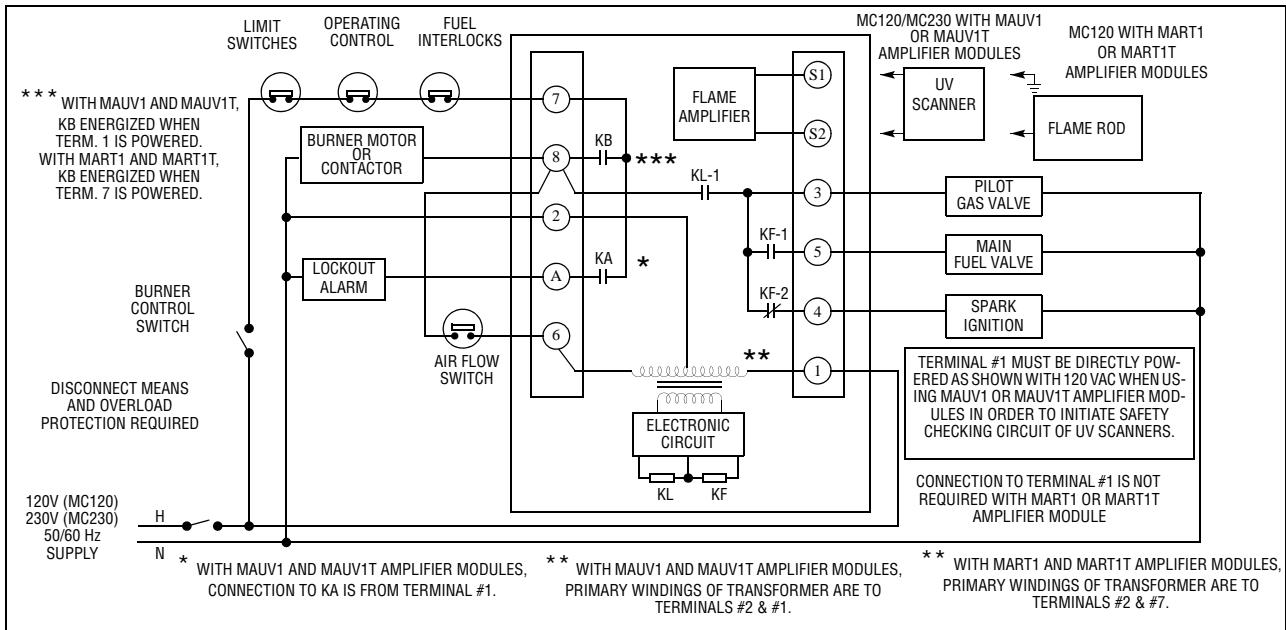

Use moisture resistant wire suitable for at least 90°C.



**CAUTION:** When powered, 560 VAC across S1, S2 with MAUV1 and MAUV1T; 260 VAC across S1, S2 with MART1 and MART1T.

**FIGURE 2.** TYPICAL MP100, MP100E, MP101, MP230, AND MP230H WIRING ARRANGEMENT FOR DIRECT SPARK IGNITED BURNER **MC120, MC120R, MC230, MC230R CHASSIS ONLY.**

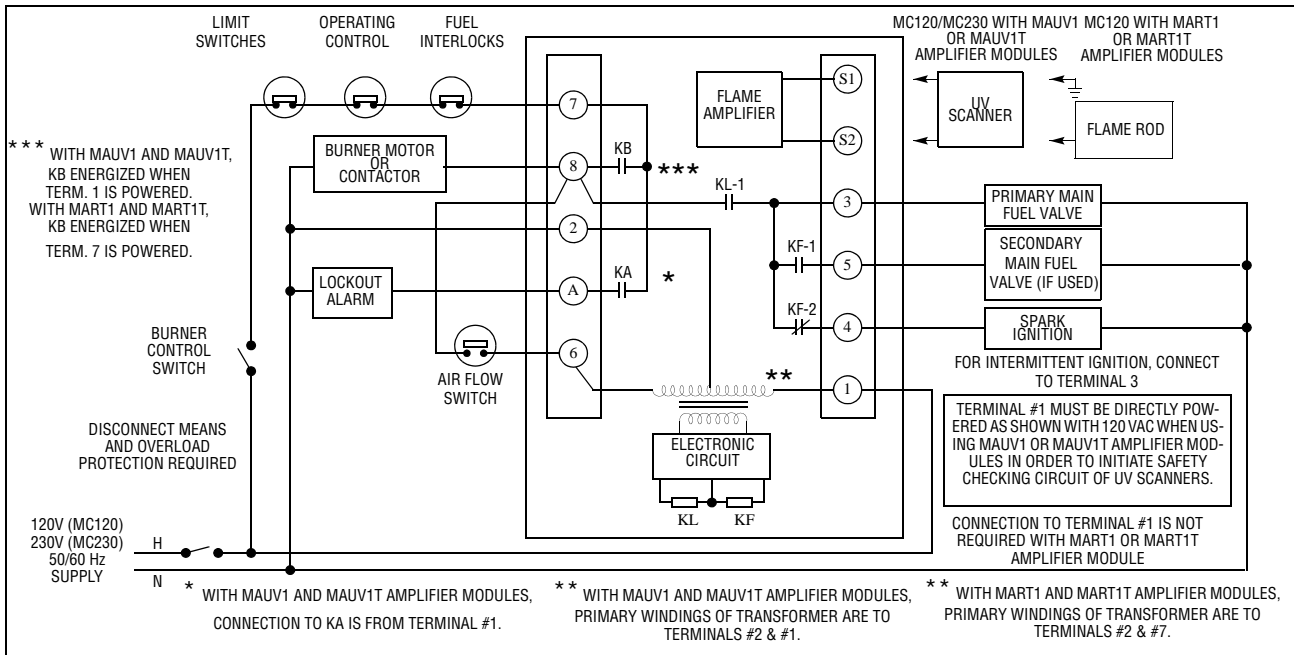

Use moisture resistant wire suitable for at least 90°C.



**CAUTION:** When powered, 560 VAC across S1, S2 with MAUV1 and MAUV1T; 260 VAC across S1, S2 with MART1 and MART1T.

**CAUTION:** Control wiring procedures which deviate from those shown in the diagrams may bypass safety functions designed in the control. Check with the Fireye Representative before deviating from the recommended wiring diagrams.

**FIGURE 3. ALTERNATE WIRING ARRANGMENT FOR MP100 CONTROLS**

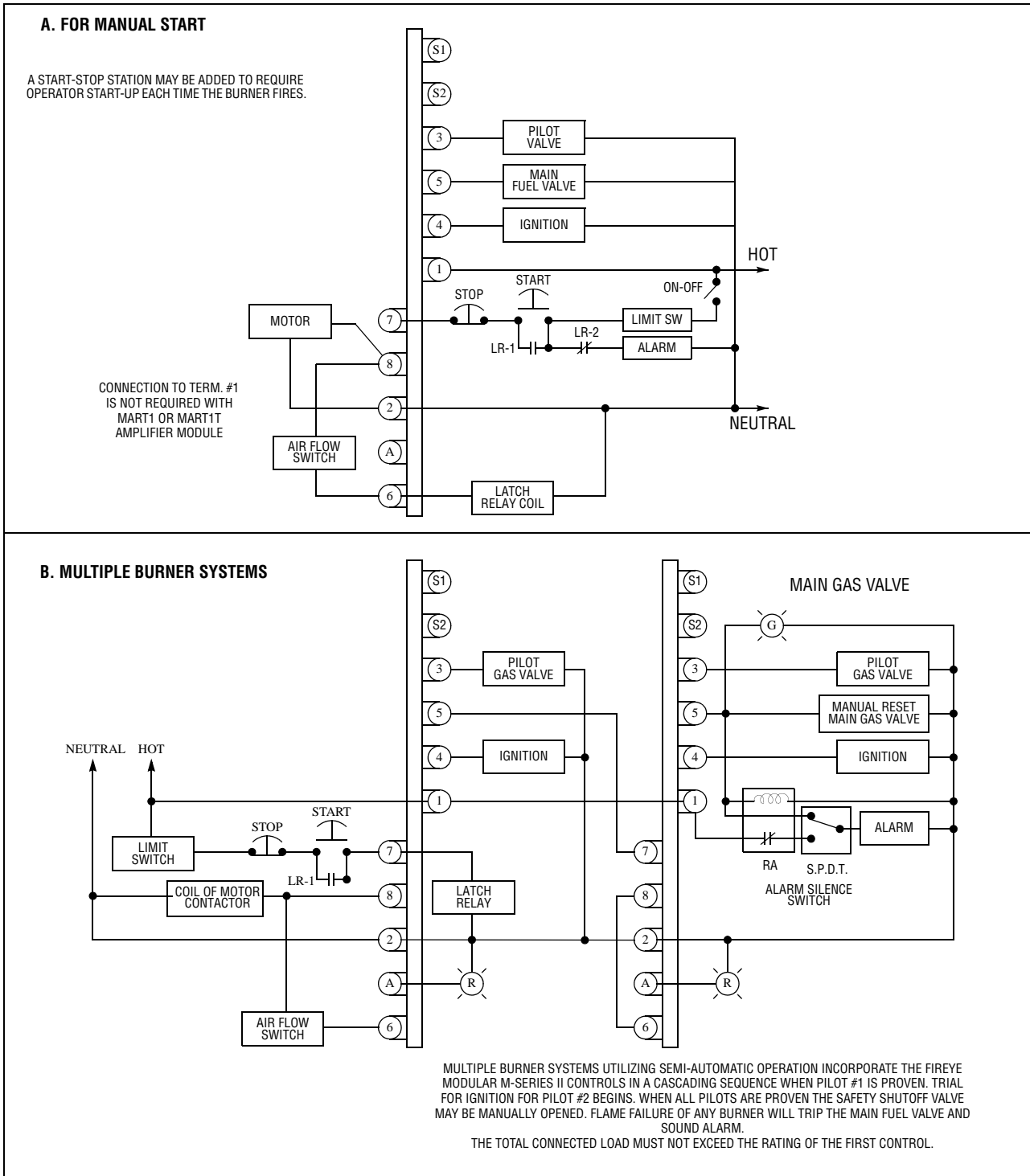

Use moisture resistant wire suitable for at least 90°C.



**CAUTION:** Control wiring procedures which deviate from those shown in the diagrams may bypass safety functions designed in the control. Check with the Fireye Representative before deviating from the recommended wiring diagrams.

**FIGURE 4.** TYPICAL MP560, MP561, MP562 WIRING ARRANGEMENT FOR PILOTED IGNITED BURNER. MC120, MC120R, MC230, MC230R, CHASSIS ONLY.

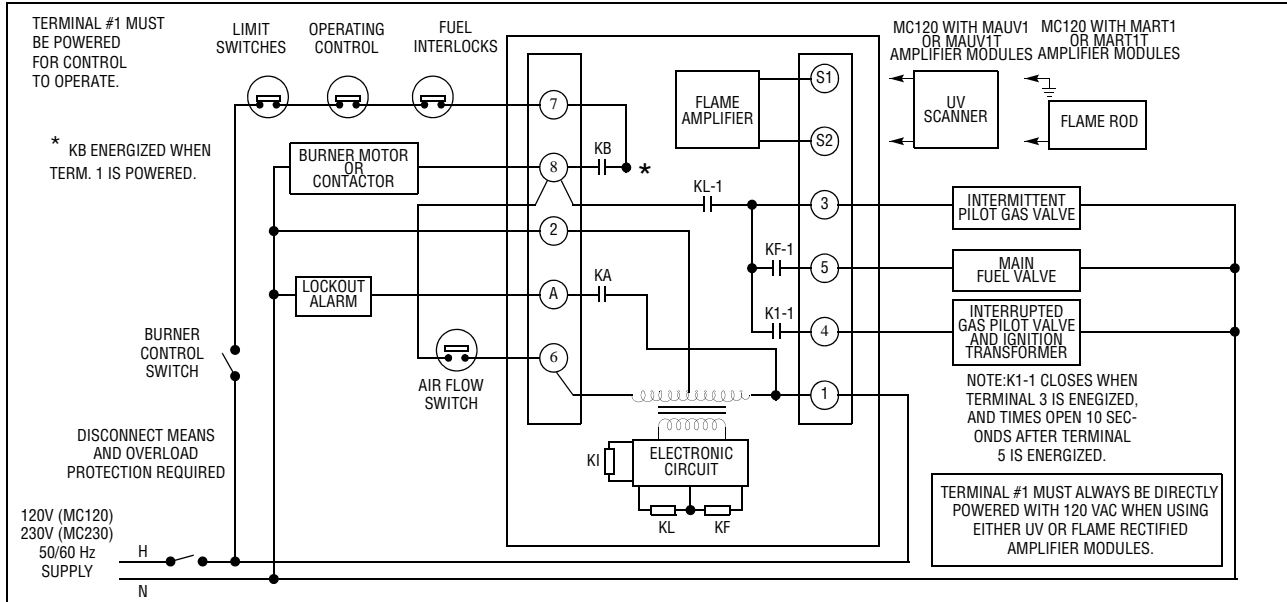

Use moisture resistant wire suitable for at least 90°C.



**CAUTION:** When powered, 560 VAC across S1, S2 with MAUV1 and MAUV1T; 260 VAC across S1, S2 with MART1 and MART1T.

**FIGURE 5.** TYPICAL MP560, MP561, MP562 WIRING ARRANGEMENT FOR DIRECT SPARK IGNITED BURNER. MC120, MC120R, MC230, MC230R CHASSIS ONLY.

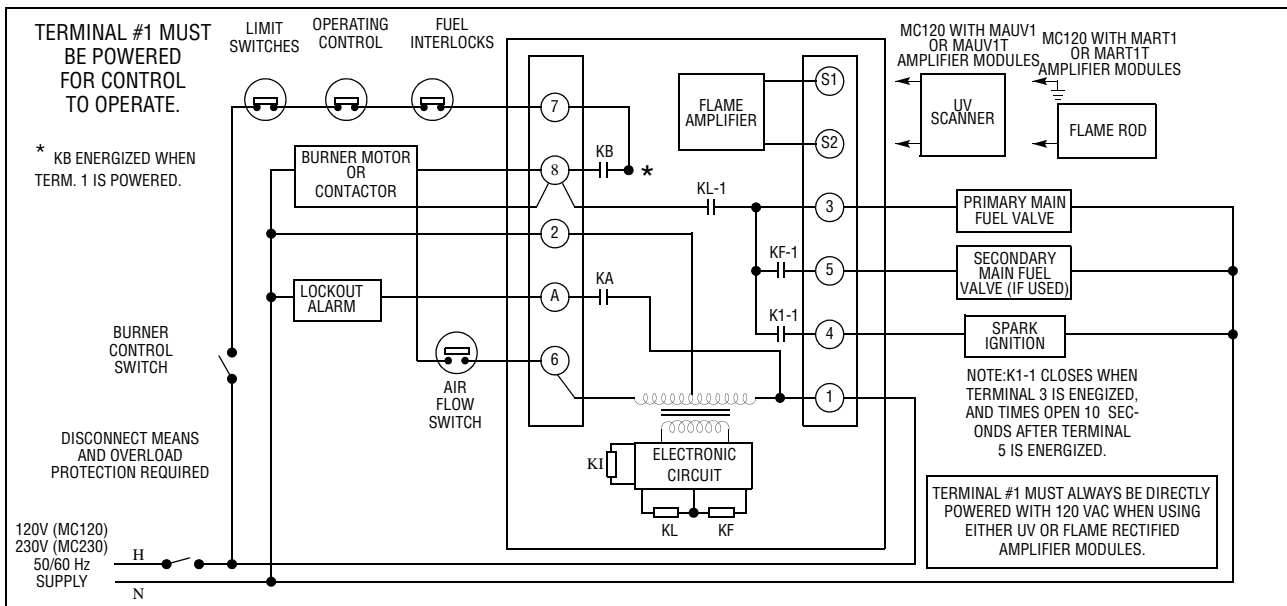

Use moisture resistant wire suitable for at least 90°C.



**FIGURE 6.** TYPICAL MP100, MP100E, MP101, MP230, and MP230H WIRING ARRANGEMENT FOR PILOT IGNITED BURNER. MC120P CHASSIS ONLY.

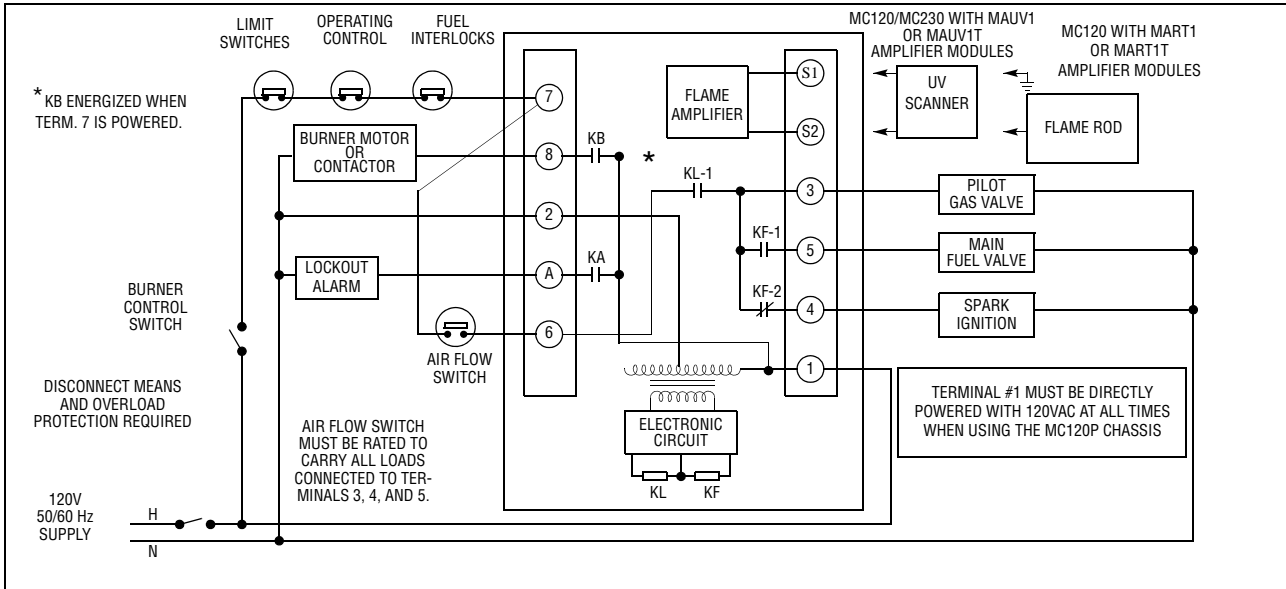

Use moisture resistant wire suitable for at least 90°C.



**CAUTION:** When powered, 560 VAC across S1, S2 with MAUV1 and MAUV1T; 260 VAC across S1, S2 with MART1 and MART1T.

**FIGURE 7.** TYPICAL MP100, MP100E, MP101, MP230, AND MP230H WIRING ARRANGEMENT FOR DIRECT SPARK IGNITED BURNER. MC120P CHASSIS ONLY.,

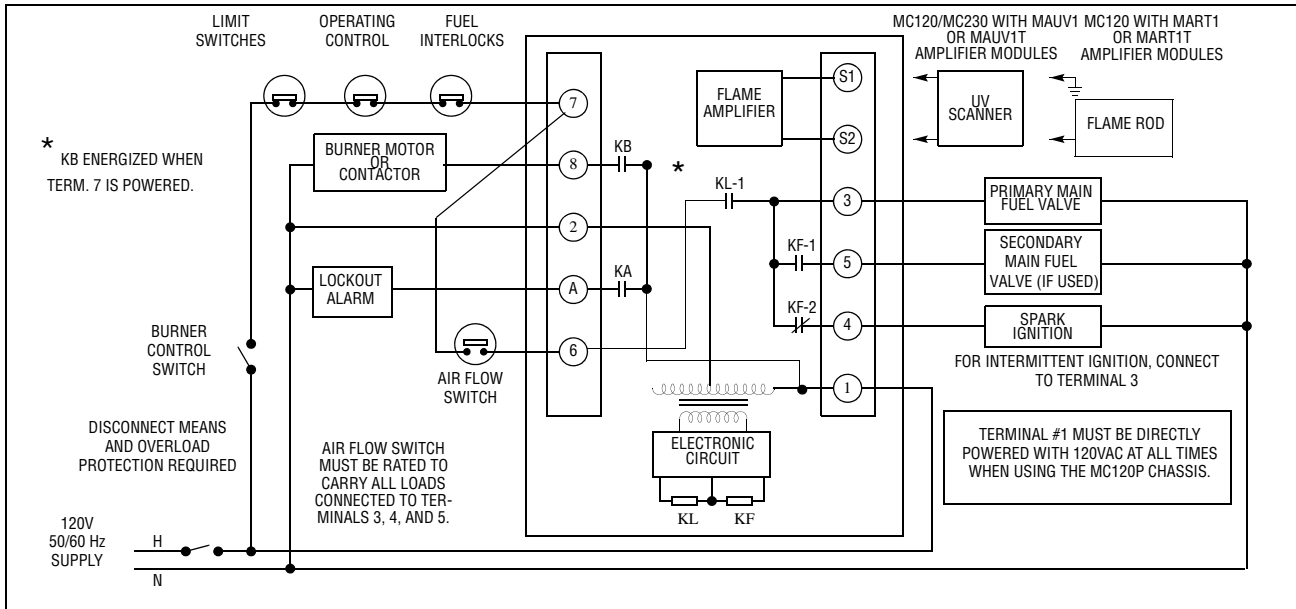

Use moisture resistant wire suitable for at least 90°C.



**CAUTION:** When powered, 560 VAC across S1, S2 with MAUV1 and MAUV1T; 260 VAC across S1, S2 with MART1 and MART1T.



**CAUTION:** Control wiring procedures which deviate from those shown in the diagrams may bypass safety functions designed in the control. Check with the Fireye Representative before deviating from the recommended wiring diagrams.

**FIGURE 8.** TYPICAL MP560, MP561, MP562 WIRING ARRANGEMENT FOR PILOTED IGNITED BURNER. MC120P CHASSIS ONLY.

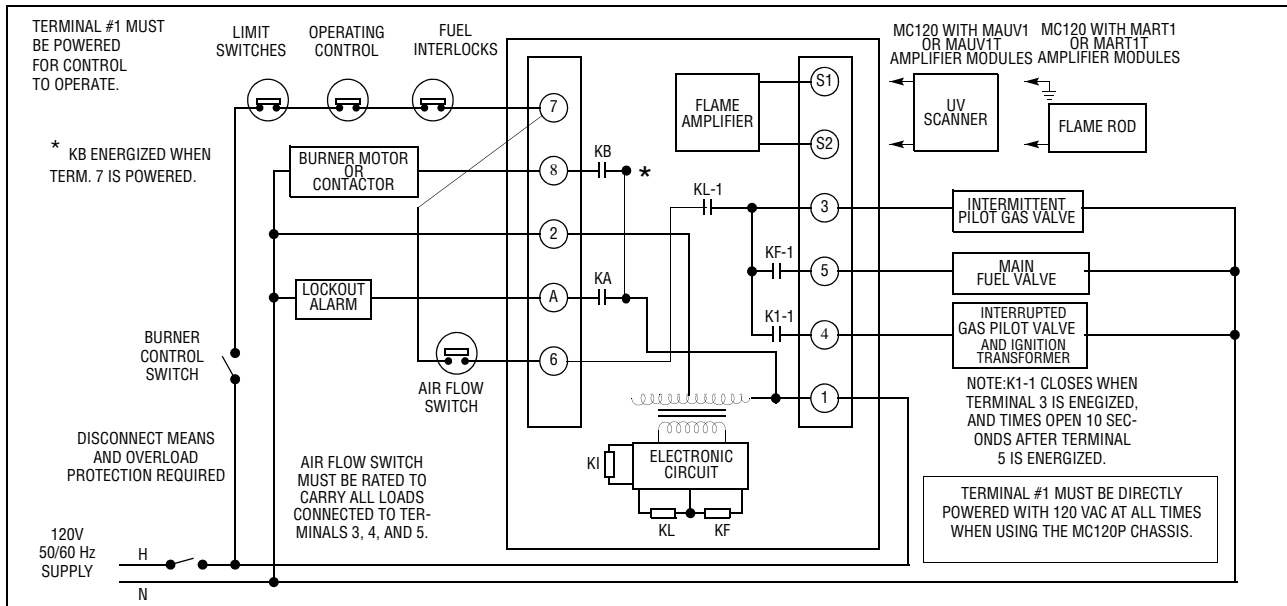

Use moisture resistant wire suitable for at least 90°C.



**CAUTION:** When powered, 560 VAC across S1, S2 with MAUV1 and MAUV1T; 260 VAC across S1, S2 with MART1 and MART1T.

**FIGURE 9.** TYPICAL MP560, MP561, MP562 WIRING ARRANGEMENT FOR DIRECT SPARK IGNITED BURNER. MC120P CHASSIS ONLY.

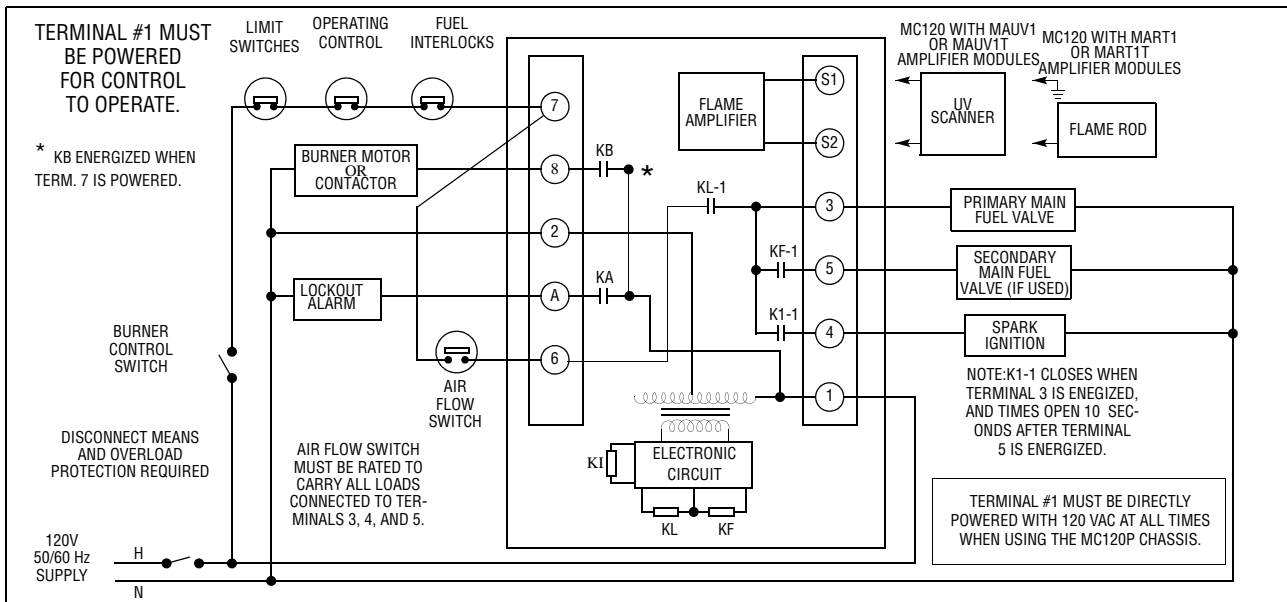

Use moisture resistant wire suitable for at least 90°C.



**CAUTION:** When powered, 560 VAC across S1, S2 with MAUV1 and MAUV1T; 260 VAC across S1, S2 with MART1 and MART1T.



**CAUTION: Control wiring procedures which deviate from those shown in the diagrams may bypass safety functions designed in the control. Check with the Fireye Representative before deviating from the recommended wiring diagrams.**

**M-SERIES II CROSS REFERENCE LISTING**

M-SERIES Part Number	M-SERIES II REPLACEMENT MODULES				Programmer Dipswitch #8
	Chassis	Amplifier	Programmer		
UVM1D	MC120	MAUV1T	MP100		N/A
UVM1F	MC120	MAUV1	MP100		N/A
TFM1D	MC120	MART1T	MP100		See Note #1
TFM1F	MC120	MART1	MP100		See Note #1
UVM2	MC120	MAUV1	MP230		OFF
TFM2	MC120	MART1	MP230		OFF
UVM3	MC120	MAUV1	MP230		ON
TFM3	MC120	MART1	MP230		ON
UVM3H	MC120	MAUV1	MP230H		ON
TFM3H	MC120	MART1	MP230H		ON
UVM5	MC120	MAUV1	MP560		ON
UVM6	MC120	MAUV1	MP560		See Note #2

- N/A — Not Applicable  
 - Programmer Dipswitches apply to MP230, MP230H, and MP560 Programmers  
 - Dipswitch #8 sets Recycle / Non-Recycle Operation. (ON = Non-Recycle, OFF = Recycle)  
 - MP560 Programmer Module has "Check-Run" Switch.  
 - Note 1: For standing pilot, clip out red jumper on MP100.  
 - Note 2: Dipswitch #8 - ON when red jumper of UVM6 is clipped. Otherwise, Dipswitch #8 = OFF.

M-SERIES TIMING CARDS	M-SERIES II PROGRAMMER DIPSWITCH SETTINGS						
	#1	#2	#3	#4	#5	#6	#7
MT55	ON	OFF	OFF	OFF	OFF	ON	OFF
MT74	OFF	ON	OFF	OFF	OFF	ON	OFF
MT304	OFF	OFF	ON	OFF	OFF	ON	OFF
MT710	OFF	ON	OFF	OFF	OFF	OFF	ON
MT904	OFF	OFF	ON	ON	OFF	ON	OFF
MT3010	OFF	OFF	ON	OFF	OFF	OFF	ON
MT6010	OFF	OFF	OFF	ON	OFF	OFF	ON
MT9010	OFF	OFF	ON	ON	OFF	OFF	ON

- Dipswitches #1 through #5 set Purge Timing.  
 - Dipswitches #6 and #7 set TFI Timing.

Dipswitch #	Off	On	
1	-	5	<b>PURGE TIMING</b> Values are Additive
2	-	7	
3	-	30	
4	-	60	
5	-	240	
6	-	5	<b>TFI TIMING</b>
7	-	10	
8	Recycle	Non-Recycle	



---

## NOTICE

When Fireeye products are combined with equipment manufactured by others and/or integrated into systems designed or manufactured by others, the Fireeye warranty, as stated in its General Terms and Conditions of Sale, pertains only to the Fireeye products and not to any other equipment or to the combined system or its overall performance.

---

## WARRANTIES

FIREYE guarantees for *one year from the date of installation or 18 months from date of manufacture* of its products to replace, or, at its option, to repair any product or part thereof (except lamps, electronic tubes and photocells) which is found defective in material or workmanship or which otherwise fails to conform to the description of the product on the face of its sales order. **THE FOREGOING IS IN LIEU OF ALL OTHER WARRANTIES AND FIREYE MAKES NO WARRANTY OF MERCHANTABILITY OR ANY OTHER WARRANTY, EXPRESS OR IMPLIED.** Except as specifically stated in these general terms and conditions of sale, remedies with respect to any product or part number manufactured or sold by Fireeye shall be limited exclusively to the right to replacement or repair as above provided. In no event shall Fireeye be liable for consequential or special damages of any nature that may arise in connection with such product or part.



FIREYE  
3 Manchester Road  
Derry, New Hampshire 03038  
[www.fireeye.com](http://www.fireeye.com)

C-4000  
MARCH 11, 2015  
Supersedes August 7, 2013