



# INSTALLATION INSTRUCTIONS

## 133-733

### MicroM MEP237 with Integrated Phoenix and InSight Scanners



The MicroM programmer, MEP237, with the MEDC2 amplifier, is specially designed to operate as a primary burner control and connect to the specific types of the integrated InSight and Phoenix scanner as a flame detector. **Refer to bulletins MC-5000, CU-95 and CU-114 for detailed operational information.**

The Fireye MicroM Series Flame Safeguard Control is a compact, microprocessor based, modular burner management system designed to provide automatic ignition and continuous flame monitoring for commercial sizes of heating and process equipment firing any type of fuel.

The FIREYE InSight Type 95IR, 95UV, and 95DS flame scanners are micro-processor based flame scanners utilizing solid state infrared (IR) or ultraviolet (UV) or dual (IR and UV) sensors. The FIREYE InSight Type 95 flame scanners incorporate an internal flame relay with adjustable ON/OFF thresholds. The InSight scanners incorporate elements of the FIREYE Type 45FS1 and 45UVFS1 Signature Scanners™ as well as of the Type 45RM4 flame scanners to detect the presence or absence of a target flame in single or multi-burner applications.

The InSight scanners measure the amplitude of the modulations (the flame "flicker") that occur within the targeted flame. During the scanner set-up procedure, the modulation frequency that yields the best flame ON/OFF discrimination is selected. The appropriate modulation frequency and sensor gain is either manually selected (S1 models), or automatically selected with manual override capability (S2 models).



**In order to meet compliance with national and local codes, the InSight scanner must have its FFRT (flame failure response time) set to no more than 3 seconds.**

The Standard Model S1 has three choices of modulation frequency, adjustable sensor gain, adjustable flame relay ON/OFF thresholds, 4-20 mA analog signal strength output, fault relay, and two selectable programmable files to store setpoints (for two different fuels or firing rates).



The Expanded Model S2 adds automatic programming (AutoTune) with manual override capability, 21 choices of flame flicker frequency, a total of four selectable programmable files to store setpoints, plus adds remote communication capability via Fireeye Windows 95/98/NT user software. All FIREYE InSight scanner models are powered by 24 Vdc and contain electronic self-checking (no mechanical shutter required). The scanners contain an eight character alpha-numeric LED display and a four (4) push-button keypad to enable the user to view operating parameters and select setpoints.

The Fireeye Phoenix scanner types 85UVF4-1QDWR, 85IRF4-1QDWR, 85UVF4-2QDWR and 85IRF4-2QDWR are unique versions of the standard Phoenix microprocessor based devices specifically designed to interconnect and operate with Fireeye Flame Safeguard Controls. These versions are also rated for installation in hazardous locations. The -2QDWR are fiber optic versions of the standard models.

The Phoenix flame scanners incorporate an internal flame relay with automatically set ON/OFF thresholds. Phoenix scanners detect the amplitude of the modulations (the flame "flicker") that occur within the targeted flame, over a wide frequency. During the scanner set-up procedure, the amplitudes of the target flame are automatically stored by the flame scanner, together with optimum ON/OFF criteria. The appropriate sensor gain is automatically selected. Phoenix scanners incorporate full self -diagnostics and electronic self-checking.

All models of the Phoenix flame scanners are housed within an engineered material making them incredibly strong but lightweight and easy to handle. The housing material is designed to meet the requirements of NEMA 4X (IP66).

The Insight scanner housing is cast aluminum with gray polyester powder coat finish and meets NEMA 4X (IP66).

Refer to bulletins CU-114 and CU-95 for exact scanner environmental classifications.

***The Phoenix and Insight flame scanners are powered by 24Vdc (supplied separately). The 24 Vdc supply must be powered from the same mains supply as the MicroM. See wiring diagrams.***



## SCANNER ORDERING INFORMATION

<b>PHOENIX SCANNERS</b> (see note)	
85UVF4-1QDWR	Phoenix Integrated Scanner, 4 sec FFRT – Ultra-violet with 8-pin electrical quick disconnect. FM, UL_CUS approved.
85UVF4-1QDK3WR	Fiber optic version of Phoenix K3 Integrated Scanner, 4 sec FFRT – Ultra-violet with 8-pin electrical quick disconnect. FM, UL_CUS approved.
85UVF4-2QDWR	Fiber optic version of standard Phoenix Integrated Scanner, 4 sec FFRT – Ultra-violet with 8-pin electrical quick disconnect. FM, UL_CUS approved.
85UVF4-2QDK3WR	Fiber optic version of Phoenix K3 Integrated Scanner, 4 sec FFRT – Ultra-violet with 8-pin electrical quick disconnect. FM, UL_CUS approved.
85IRF4-1QDWR	Phoenix Integrated Scanner, 4 sec FFRT – Infrared with 8-pin electrical quick disconnect. FM, UL_CUS approved.
85IRF4-2QDWR	Fiber optic version of standard Phoenix Integrated Scanner, 4 sec FFRT – Infrared with 8-pin electrical quick disconnect. FM, UL_CUS approved.
35-318-1	Mounting flange for Phoenix, 1" NPT
35-318-2	Mounting flange for Phoenix, 1" BSP
<b>PHOENIX CABLES</b>	
59-546-3	8-Conductor 3-meter (9 ft. 10 in.) cable assembly with 8-pin female connector.
59-546-6	8-Conductor 6-meter (19 ft. 8 in.) cable assembly with 8-pin female connector.
59-546-9	8-Conductor 9-meter (29 ft. 3 in.) cable assembly with 8-pin female connector.
59-546-12	8-Conductor 12-meter (39 ft. 4 in.) cable assembly with 8-pin female connector.
59-546-15	8-Conductor 15-meter (49 ft. 2 in.) cable assembly with 8-pin female connector.
59-546-30	8-Conductor 30-meter (98 ft. 5 in.) cable assembly with 8-pin female connector.
59-546-45	8-Conductor 45-meter (147 ft. 7 in.) cable assembly with 8-pin female connector.
59-546-60	8-Conductor 60-meter (196 ft. 10 in.) cable assembly with 8-pin female connector.
59-546-90	8-Conductor 90-meter (295 ft. 3 in.) cable assembly with 8-pin female connector.
<b>INSIGHT SCANNERS</b>	
95IRS2-1	Enhanced Model InSight Scanner – Infrared with quick disconnect, FM, UL_CUS approved.
95UVS2-1	Enhanced Model InSight Scanner – Ultra-violet with quick disconnect, FM, UL_CUS approved.
95DSS2-1	Enhanced Model InSight Scanner – Dual detector with quick disconnect, FM, UL_CUS approved.
60-2692	1" NPT mounting flange for InSight Scanner, includes heat insulator 35-127-1.
60-2693	1" BSP mounting flange for InSight Scanner, includes heat insulator 35-127-3.
<b>INSIGHT CABLES</b>	
59-497-020-WR	12-Conductor cable with straight connector (129-164), 20 feet.
59-497-020C-WR	12-Conductor cable with straight connector (129-164C) and flex conduit adapter, 20 feet.
59-497-020R-WR	12-Conductor cable with right angle connector (129-164R), 20 feet
59-497-020RC-WR	12-Conductor cable with right angle connector (129-164RC) and flex conduit adapter, 20 feet
<b>POWER SUPPLIES</b>	
60-2685-25	24 VDC Switching Power Supply, 100-240 vac 50/60 Hz. input, 2.5 A output at 24 vdc.
60-2685-50	24 VDC Switching Power Supply, 100-240 vac 50/60 Hz. input, 5.0 A output at 24 vdc.

**NOTE:** The Phoenix QDWR models with electrical quick-disconnect have replaced the original WR models equipped with ten feet of captive cable. The QDWR models (with 59-546-X cables) are also suitable for use in Class I Division 2 hazardous areas, thereby eliminating the need for the "EXWR" models.



The MicroM MEP237 is equipped with a set of dip switches and a run/check switch and provides the following operational characteristics:

1. Intermittent pilot operation.
2. Purge time: dip switch selectable, 7, 30, 60 or 90 seconds.
3. Pilot trial for ignition period (PTFI): Dip switch selectable 5 or 10 seconds fixed.
4. Action on pilot flame fail: Lockout.
5. Action on main flame fail: Dip switch selectable, recycle or non-recycle.
6. Action on air flow (interlock) open: Recycle.
7. Action on air flow (interlock) not closing: Indefinite hold.
8. Action on jumped air flow (interlock) at start: Dip switch selectable.
9. Run/Check switch provided for pilot trial for ignition period
10. Post purge time after operating limit or interlock opens: Dip switch selectable, 0 or 15 seconds.
11. Post purge time after flame fail during PTFI and AUTO period: 15 seconds.
12. Able to detect shorted scanner cable.
13. With MEDC2 amplifier, provides flame failure response of 0.25 seconds.

Below is the timing sequence of the MEP237 as it would operate through a normal cycle.

FUNCTION	TRM	STANDBY		PURGE	PTFI	AUTO	POST PURGE	CYCLE COMPLETE
				7-90 SECONDS	5/10 SECONDS		0/15 SECONDS	
OP CTRL	7							
AIR FLOW	6							
BLOWER	8							
PILOT	3							
IGNITION	4							
MAIN	5							
FLAME SIGNAL								

### OPERATOR & SYSTEM INTERFACE

Local interface to the Phoenix scanner is via a pushbutton keypad and information LEDs. These provide continuous indication of flame signal, flame relay status, scanner status as well as selected mode of operation. Simplified keystroke routines are used for set up and can be completed in seconds. For remote interface, outputs are provided for fault relay and 4 to 20mA flame strength, in addition to the flame signal connection for the Fireeye programming controller.

### PHOENIX WIRING DIAGRAM

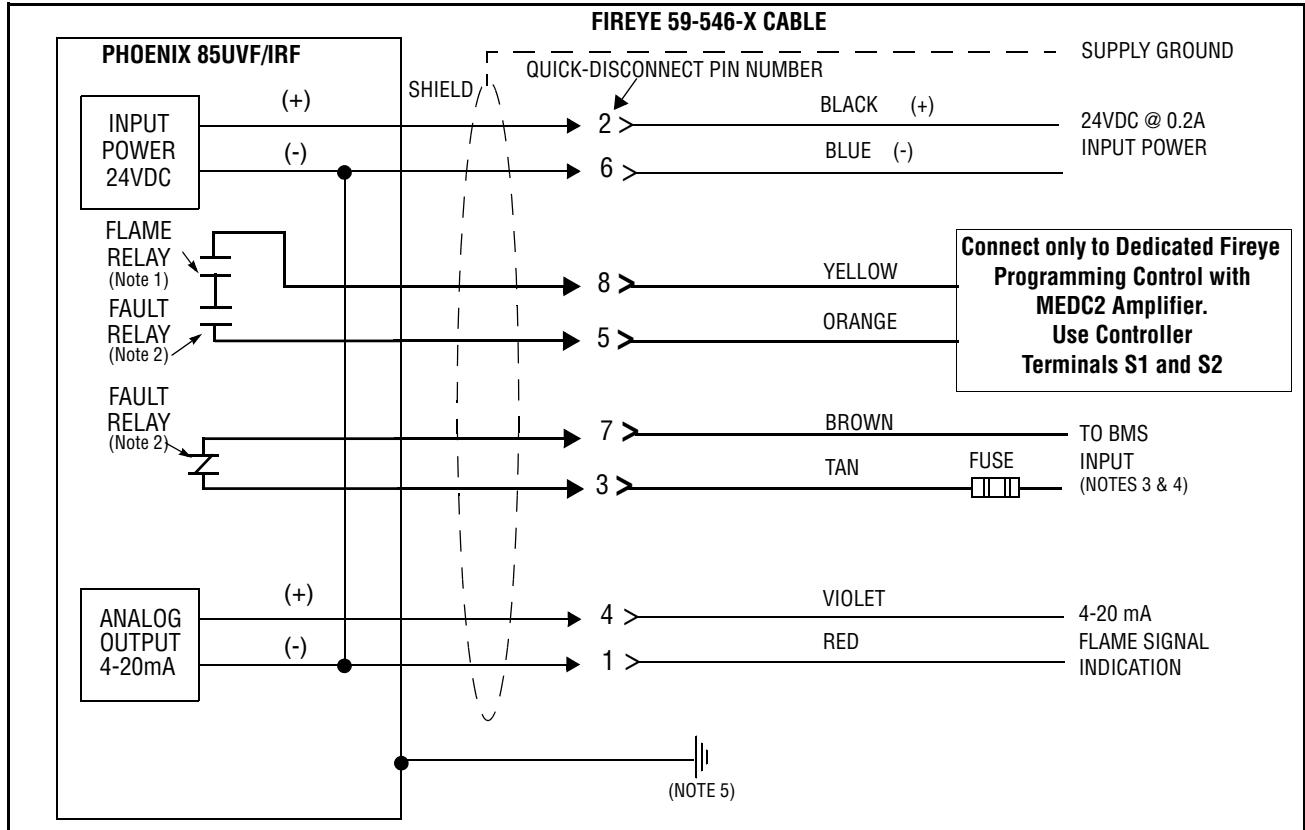

**Notes:**

1. Flame relay contacts are shown in the de-energized (no flame condition).
2. Fault relay contacts are shown in de-energized (fault) condition.
3. BMS = Burner Management System (by others). Do not use Grey/Red as 24 volt ground.
4. External 2.0 Amp fuses recommended.
5. A safety ground screw is provided on the scanner end plate. An external ground wire must be installed if line voltage is applied to the relay contacts.

**Table 1: PHOENIX SCANNER CABLE COLOR CODE**

NEW 59-546 CABLE COLOR CODE (Connector Pin No.)	FUNCTION	OLD 59-497 CAPTIVE-CABLE COLOR CODE <i>For reference only</i>
(2) Black	24 vdc Input (+)	Black / Red
(6) Blue	24 vdc Input (-)	White / Blue
(8) Yellow	Flame Relay Contact (n.o.)	White / Red
(5) Orange	Flame Relay Contact (n.o.)	White / Black
(7) Brown	Fault Relay Contact (n.c.)	Red
(3) Tan	Fault Relay Contact (n.c.)	Pink
(4) Violet	4-20 ma Analog Output (+)	Violet
(1) Red	4-20 ma Analog Output (-)	Grey / Red
Shield Drain Wire	Earth Ground	Shield Drain Wire



### INSIGHT WIRING DIAGRAM

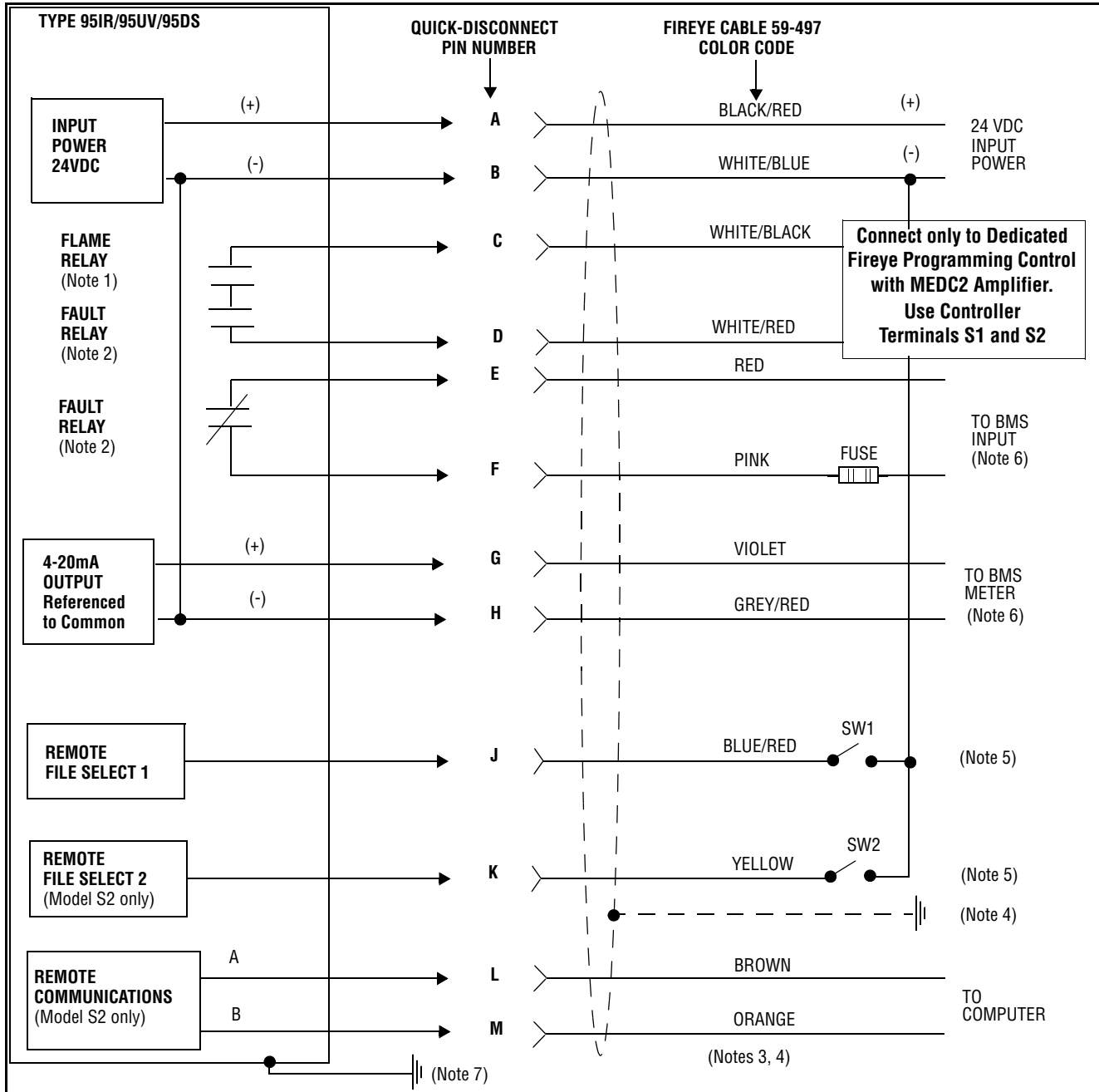

**Notes:**

1. Flame relay contacts are shown in de-energized (no flame) condition.
2. Fault relay contacts are shown in de-energized (fault) condition.
3. Brown and orange wires are a twisted pair.
4. **Connect cable shield to earth ground at power source.**
5. With Remote File Select programmed as "LINE", external switches SW1/SW2 (not furnished) will select between two (S1 Models) or four (S2 Models) internal memory files, when connected to 24Vdc (-) supply.
6. External 2.0 Amp fuses recommended.
7. **A ground screw is provided on the scanner end plate. An external ground wire must be installed if line voltage is applied to the relay contacts.**

## MicroM WIRING DIAGRAM

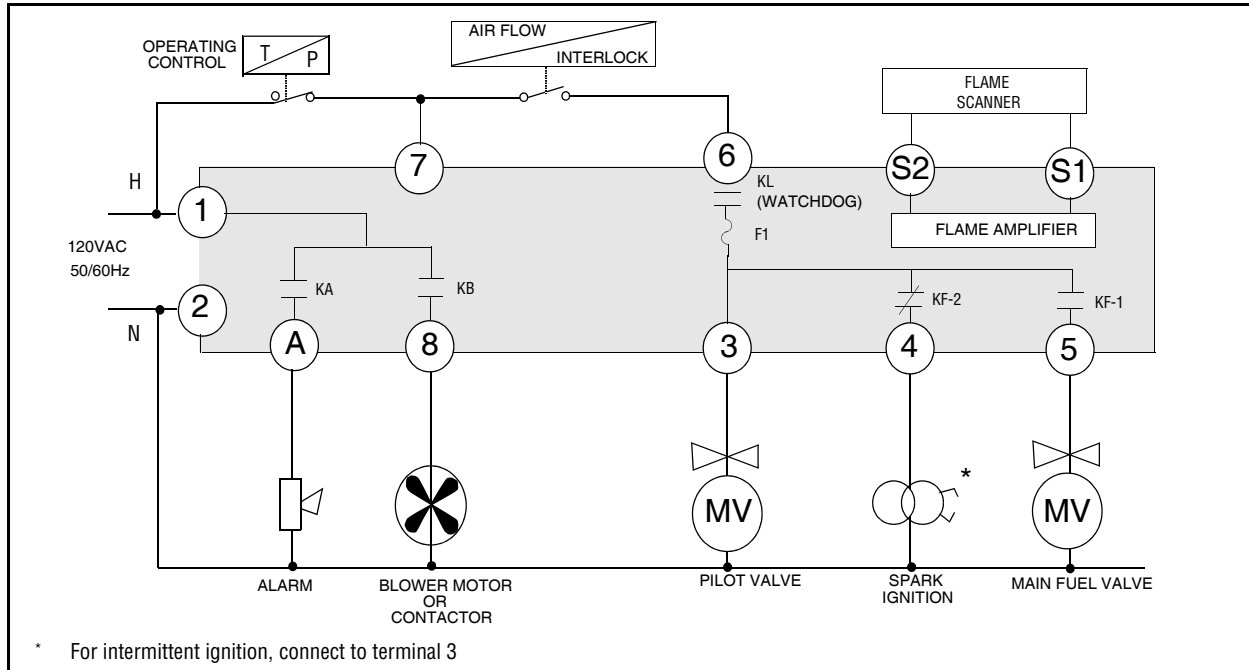

### NORMAL OPERATION

With power applied and the limit operating control circuit (1-7) closed, the Operating Control LED illuminates, the burner motor circuit is energized (Terminal 8).

After the air flow proving switch (7-6) closes, the interlock (air flow) LED is illuminated and a time pre-purge delay dependent on the dip switch setting begins.

At the expiration of the safe start check period, a 10 second pilot trial for ignition (PTFI) period is initiated, illuminating the PTFI Led. Power is applied to Terminal 3, energizing the pilot gas valve and to Terminal 4, energizing the spark ignition.

At the detection of pilot flame, the FLAME LED is illuminated.

At the expiration of the selectable 5 or 10 second PTFI period and with flame detected, the PTFI Led is extinguished and power is then applied to Terminal 5, energizing the main fuel valve and removing power from Terminal 4, turning off the spark igniter.

When the operating control opens, the control de-energizes Terminal 3 and Terminal 5 and the programmer reverts back to the STANDBY state.

### INITIAL SETUP

The MEP237 provides a RUN / CHECK switch that halts the programmer during the Pilot Trial for Ignition period. The MicroM will keep the pilot valve (3) and ignition transformer (4) energized during this period. In order for the Insight or Phoenix scanner to provide a contact closure to the MicroM, it must first be placed in the learn mode during the pilot establishing period. **Refer to bulletin CU-95 and CU-114 for the Insight and Phoenix learn procedures.** During the CHECK mode the MicroM provides up to 30 seconds of no flame signal to have the INSIGHT and PHOENIX scanner learn the pilot flame signal. After successfully learned the MicroM can be placed in the RUN mode to advance to the main flame or AUTO stage.



FIREYE®  
3 Manchester Road  
Derry, New Hampshire 03038 USA  
[www.fireeye.com](http://www.fireeye.com)

133-733  
MARCH 20, 2015  
supersedes March 3 2014