



CONNECTING A PPC4000 OR PPC6000 TO A FLAME SAFEGUARD

PR-00-2-0100-0-012-A

The Basics

What is the Difference Between a PPC4000/PPC6000 and an NXF4000/NX6100?

All of the systems mentioned above are parallel positioning systems. However, you can further break down the functionality to two primary duties: burner management (BMS) and combustion control (CCS). The NXF4000 and the NX6100 handle both duties, meaning that they both establish and control the flame as well as manage the parallel positioning of the servos. The PPC4000 and PPC6000 only handle the parallel positioning, leaving the burner management to an external flame safeguard.

The Basics

Why Would You Want an External Flame Safeguard?

While the NXF4000 and NX6100 can fit most applications, there are times when an external flame safeguard may be a better solution.

Some reasons for this:

- The flame safeguard offers additional features such as expanded annunciation or custom timings
- Retrofitting of a different parallel positioning system that also had an external flame safeguard
- The flame safeguard offers different flame scanning options
- User preference

How It Works

How the PPC4000 or PPC6000 Appears to the Flame Safeguard

- The flame safeguard was originally intended to control some kind of linear actuator (modulating motor). The actuator takes signals from the flame safeguard to go to the minimum (low fire), maximum (high fire) or auto (free to modulate). In turn, the actuator then relays back to the flame safeguard if the commanded position has been reached. This closed loop design provides safety to make sure that the actuator is doing what the flame safeguard needs it to do. Once in auto, an external controller can modulate the actuator to maintain the setpoint.

- The PPC4000 or PPC6000 connect to these same inputs and reply to the same outputs to appear to the flame safeguard as if they are a standard linear actuator. An easy way to understand this is to realize that in the standard burner bill of materials, an entire PPC4000 or PPC6000 parallel positioning system replaces one standard linear actuator.

How It Works

How the Standard Linear Actuator Works

- The standard linear actuator has a single shaft that moves in a linear relation to the control signal. In theory, if the command is 4mA or 0 ohms, it will be at low fire. At 12mA or 67.5 ohms, 50% fire and at 20mA or 135 ohms, high fire.
- All of the different shafts and valves are driven off of this shaft. The low and high fire positions can be set but the curve between those positions will be a direct line or arc based on the dynamic of the linkage. With a few exceptions, there is no way to optimize the positions at any point in between, with the result being that most of the modulation range

will be inefficient, having too much excess air.

- Additionally, having multiple fuels can be difficult since there is no way to change any of the parameters for each fuel. They all have to light off at the same air position, meaning at least one fuel has a low fire that is higher than it needs to be.

How It Works

How the PPC4000 or PPC6000 Improves This Limitation

- With a PPC4000 or PPC6000, every individual damper and valve can be controlled by a dedicated servo with feedback. Additionally, up to two VFDs can also be added as channels provided that feedback is available. This allows each damper, valve and VFD speed to be set for each position from purge, ignition and throughout the automatic firing range. Each fuel can also have a unique curve, meaning that the ignition position of one fuel doesn't affect the ignition and low fire position of any others.
- Once commissioning the automatic operation curve, up to 20 unique combustion

points can be programmed. This means that the combustion can be optimized for every 5% of modulation. This has the potential to greatly improve efficiency over a standard linear actuator.

Interface

Flame Safeguard Connections to Actuator

For a flame safeguard to be compatible, it must provide one (and only one) of three command outputs to the actuator at all times. These outputs must share a common terminal that allows whatever input voltage to be switched through to the actuator.

Two common flame safeguards used with actuators match these requirements are the BurnerLogix Y and the Honeywell RM7800L/RM7840L.

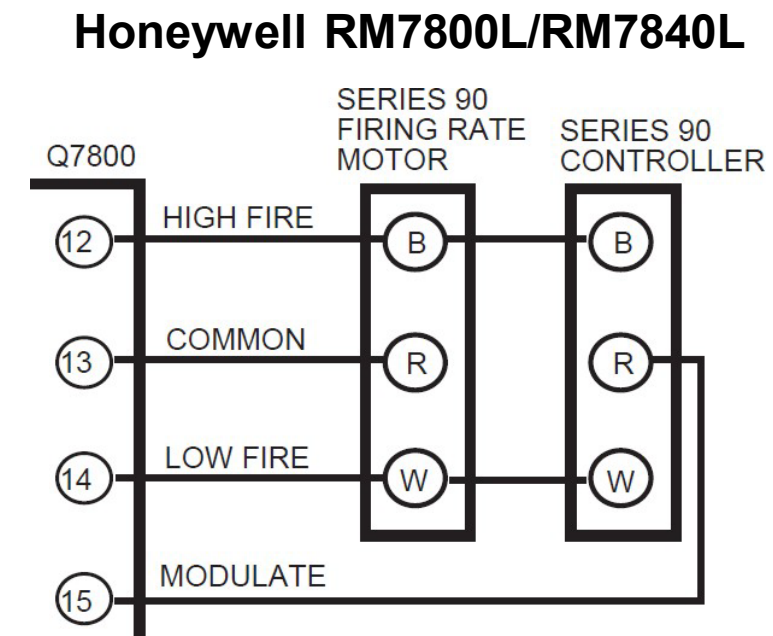
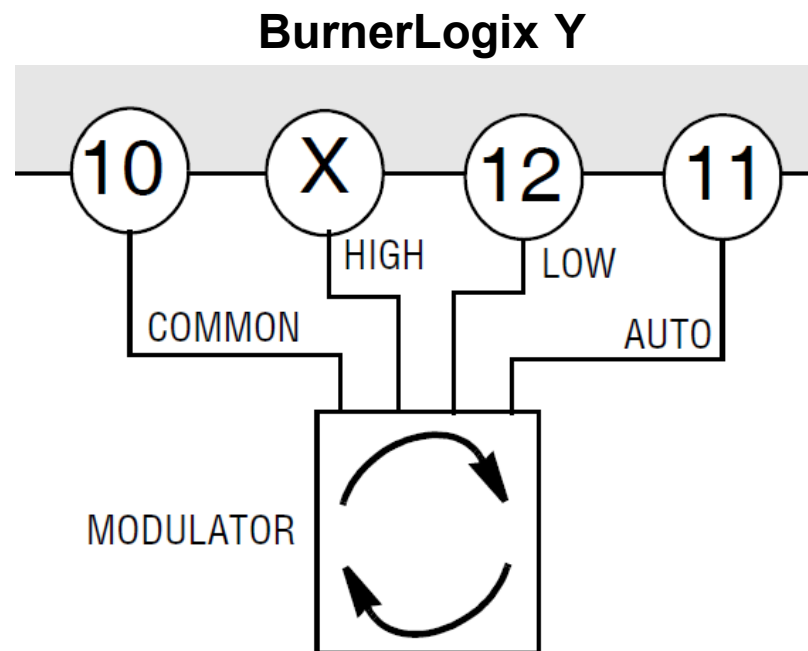

Interface

Actuator Connections to Flame Safeguard

Once it is determined that the flame safeguard can provide the necessary outputs to the actuator, it must also be verified that it will expect feedback from these commands. The BurnerLogix Y and Honeywell RM7800L/RM7840L also meet these requirements.

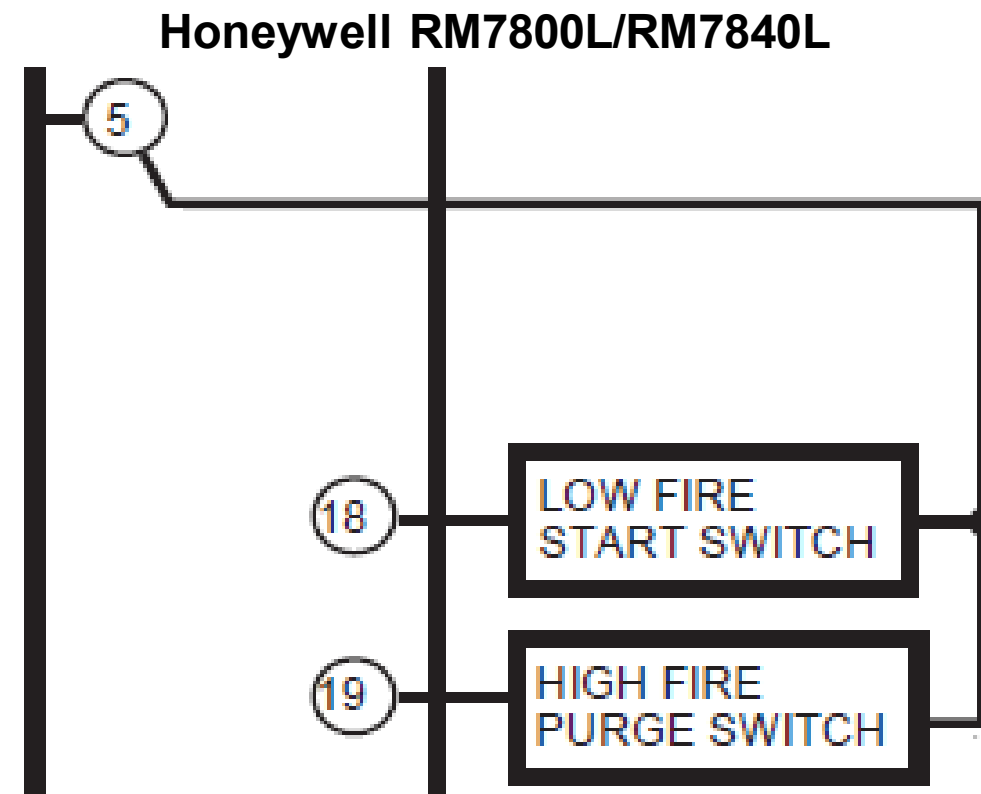
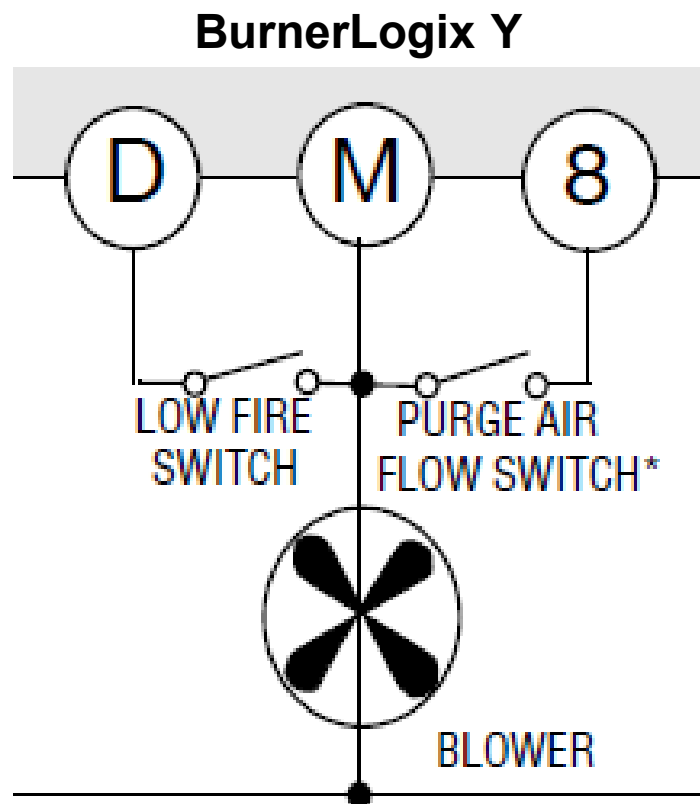

Wiring

Application Guide

The Fireeye website (www.fireeye.com) offers the “PPC4000 Wiring Application Guide”, which offers 48 different wiring diagrams to match the combination of devices and options for many applications.

A similar document for the PPC6000 will be available soon, check the website often for updates on this and other new bulletins, white papers and application notes.

Diagram Number	User Interface	Control	Program	Exp. Annun.	Firing Rate	O ₂ Trim Control	VFD	VFD Bypass	Valve Proving	Dual Fuel
PPC4000-1	NXD410	RM7800/40E,L RM7845A	---	---	PID	---	---	---	---	---
PPC4000-2	NXD410	RM7800/40E,L RM7845A	---	---	External	---	---	---	---	---
PPC4000-3	NXD410TS	RM7800/40E,L RM7845A	---	---	PID	---	---	---	---	---
PPC4000-4	NXD410TS	RM7800/40E,L RM7845A	---	---	External	---	---	---	---	---
PPC4000-5	NXD410	YB110	YP1xx	---	PID	---	---	---	---	---
PPC4000-6	NXD410	YB110	YP1xx	---	External	---	---	---	---	---



Wiring

Website navigation

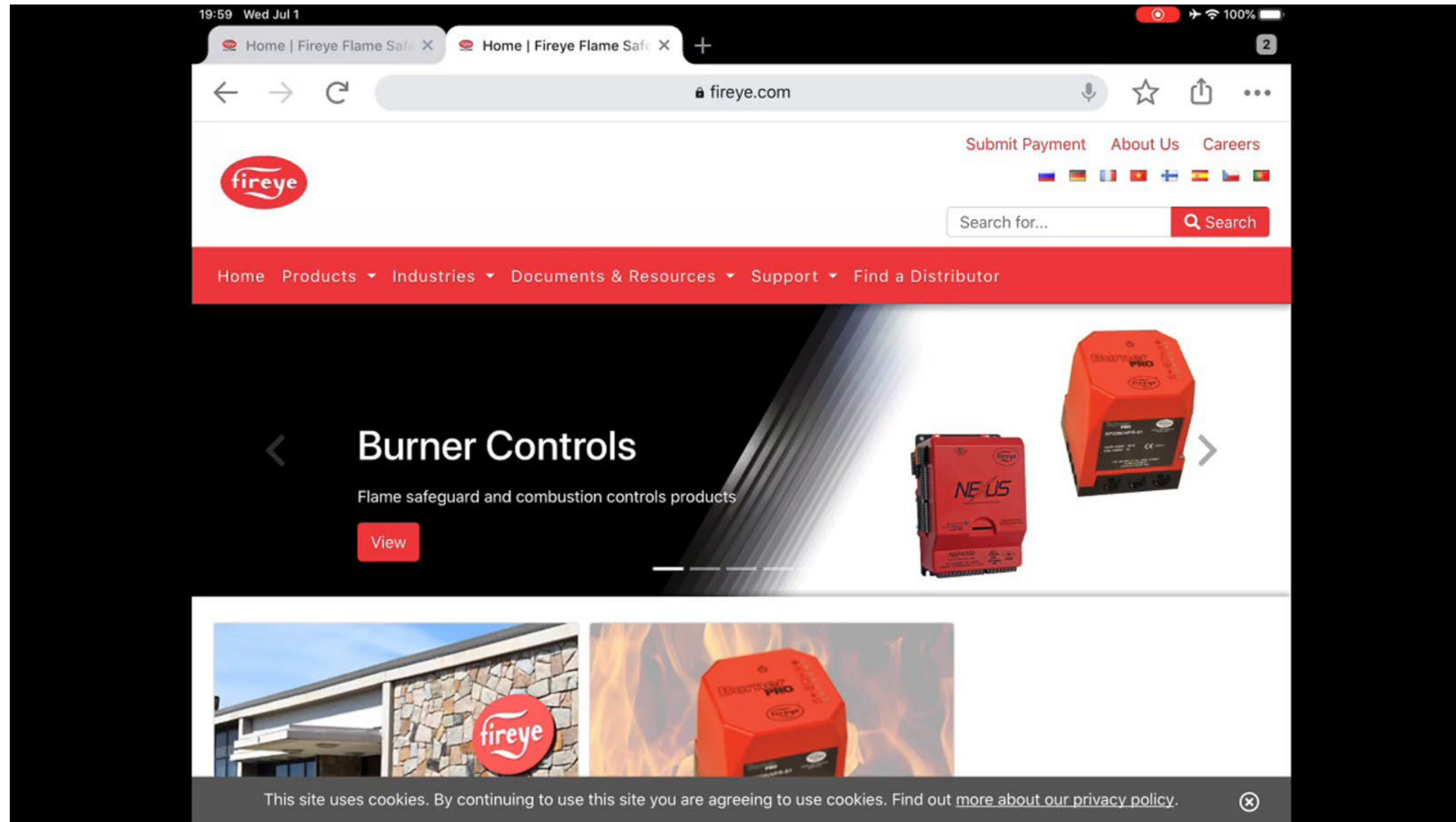

Wiring

Profile Selection and Starting Sequence

Line voltage from the flame safeguard blower output goes through a fuel selection switch. Using the blower output ensures that the flame safeguard has initiated startup and the profile selection input has the dual purpose of profile selection and starting the PPC4000 or PPC6000 sequence.

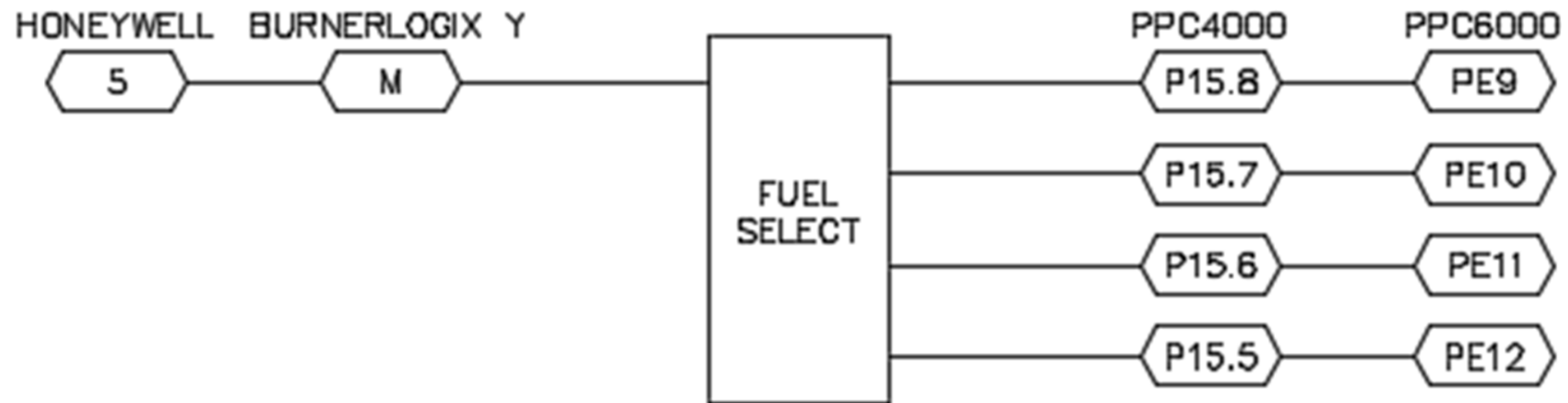

Wiring

Position Commands

For the PPC4000, line voltage is used for this. For the PPC6000, an internally-derived low voltage is used. Consult bulletin PPC-6001 for details on the wiring type and method required.

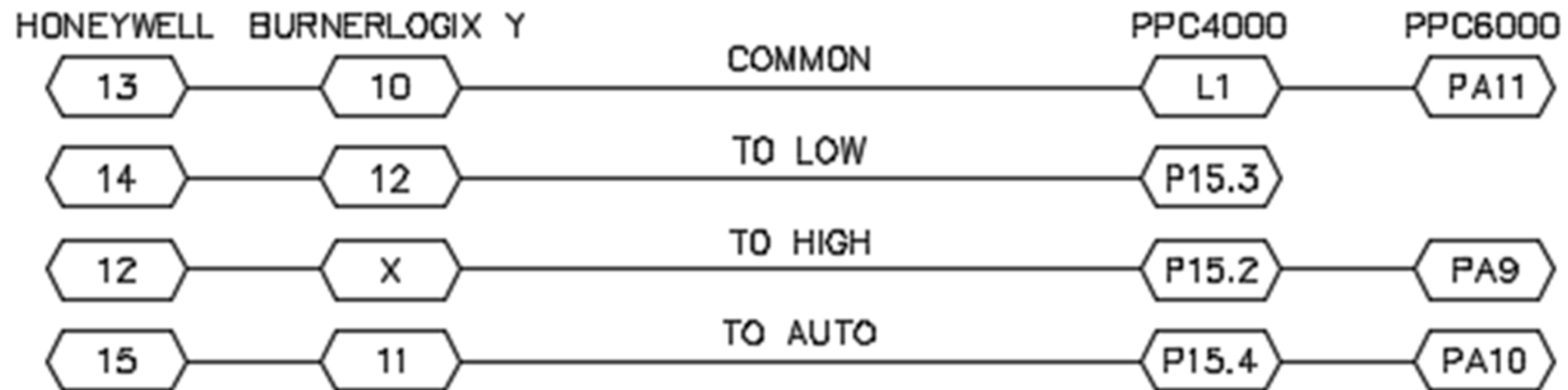

Wiring

Position command requirements

The PPC4000 requires that at any given time, only one of the position terminals has voltage. There will be a lockout if either no terminal or more than one terminal has voltage. This can be a common occurrence when first commissioning.

e12	HIGH TEMPERATURE	internal temperature is above 80C	Check Fan or provide better ventilation
e13	CHECK WIRING	User supplying line voltage to terminal to more than one of the following terminals at one time: P15-2,3,4	Check wiring
e14	CHECK WIRING	User has not connected one or more of the following terminals: P15-2,3,4	Check wiring
e15	NO AIR SERVO	The user has no servo named "AIR" in the	Name one servo in current profile "AIR"

Wiring

Feedback

Once all of the servos and VFDs reach their programmed positions for purge and ignition, feedback is provided for the flame safeguard.

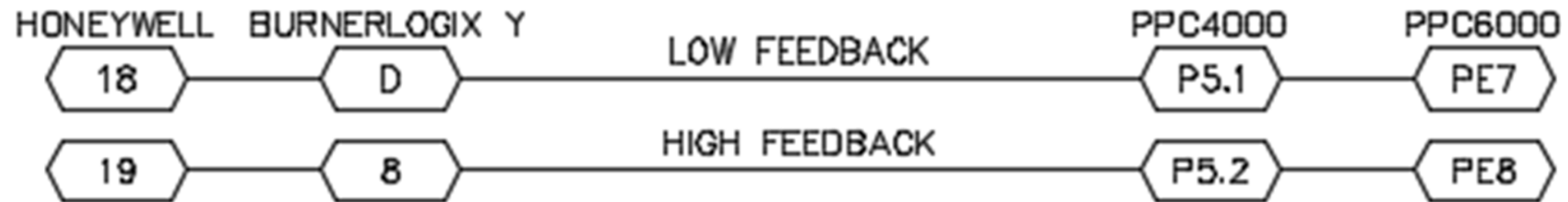

Wiring

Recycle Limits

- The PPC4000 and PPC6000 each tie into the recycle limit string. This is so the on/off switch as well as the internal load control can turn the flame safeguard on and off. The PPC4000 uses a relay (the OCRC relay) so it can be located at any point in the HONEYWELL BURNERLOGIX Y here receiving being at the PPC6000 on be at the beginning of the recycle limit string.

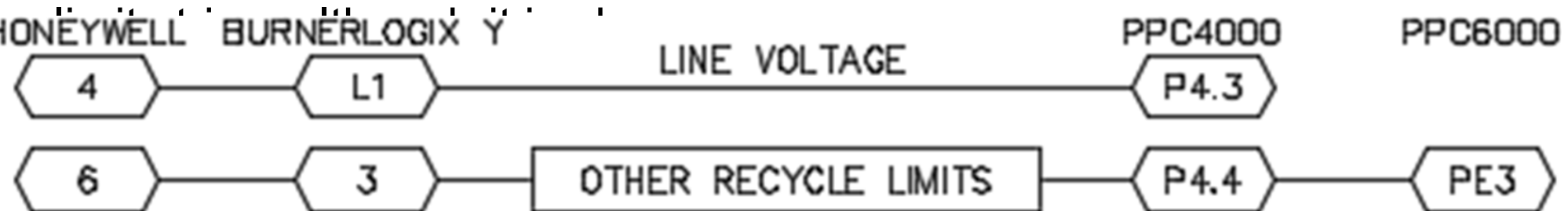

Wiring

Safety Limits

The PPC4000 and PPC6000 each tie into the safety limit string. This is so that a lockout of the PPC4000 or PPC6000 will also cause a lockout of the flame safeguard. Each of these is a relay so they can be placed at any point in the safety limit, although they are shown here receiving line voltage in to start the safety limit string.

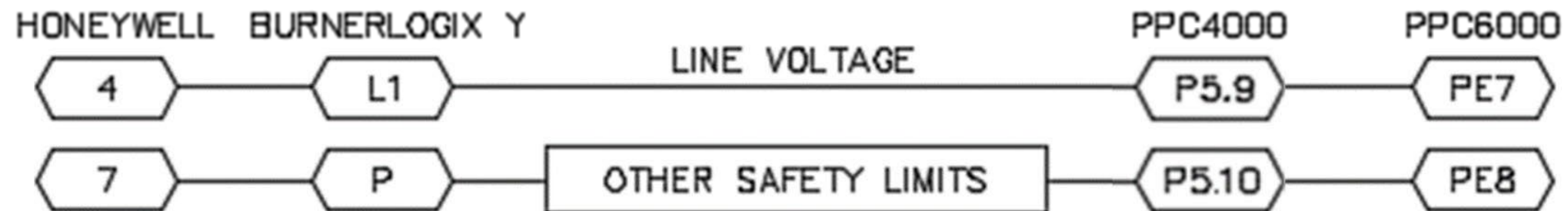

Wiring

Complete

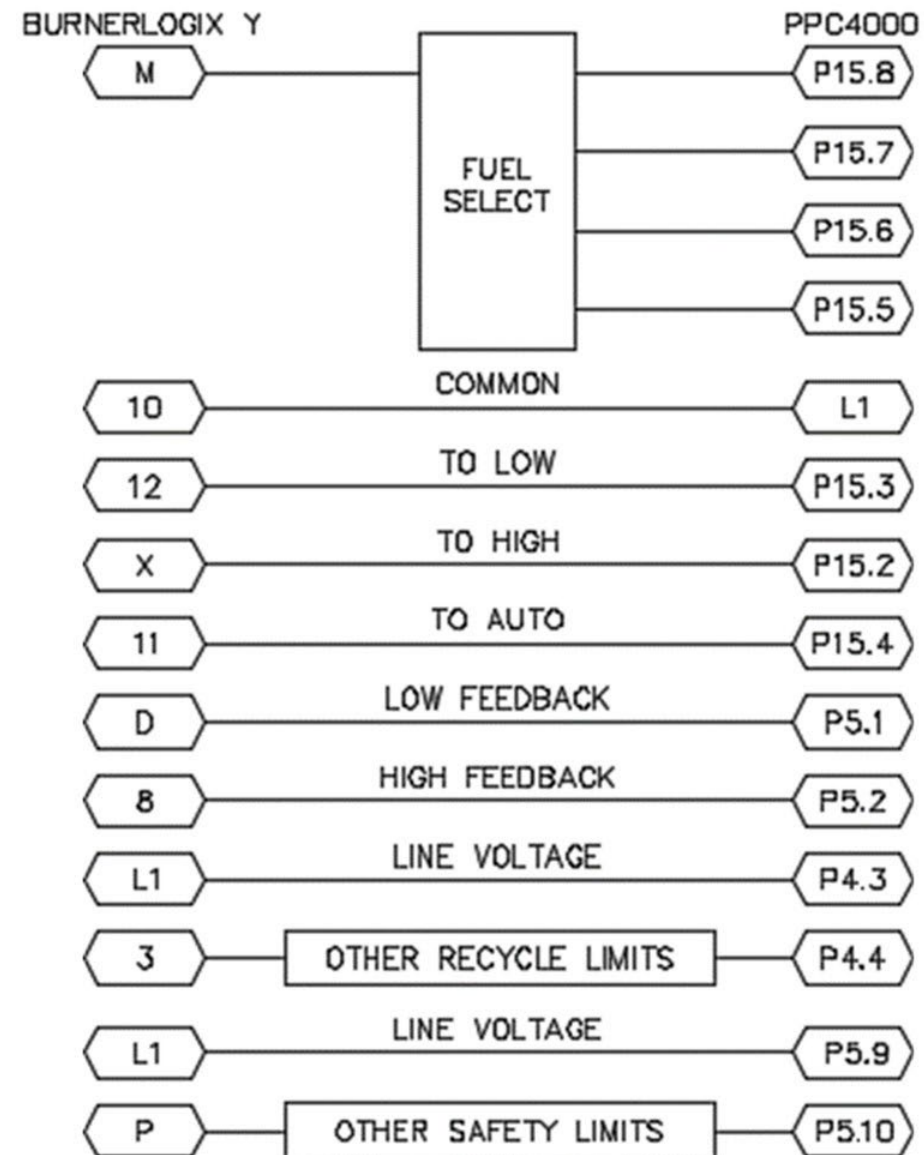

Sequence

Standby

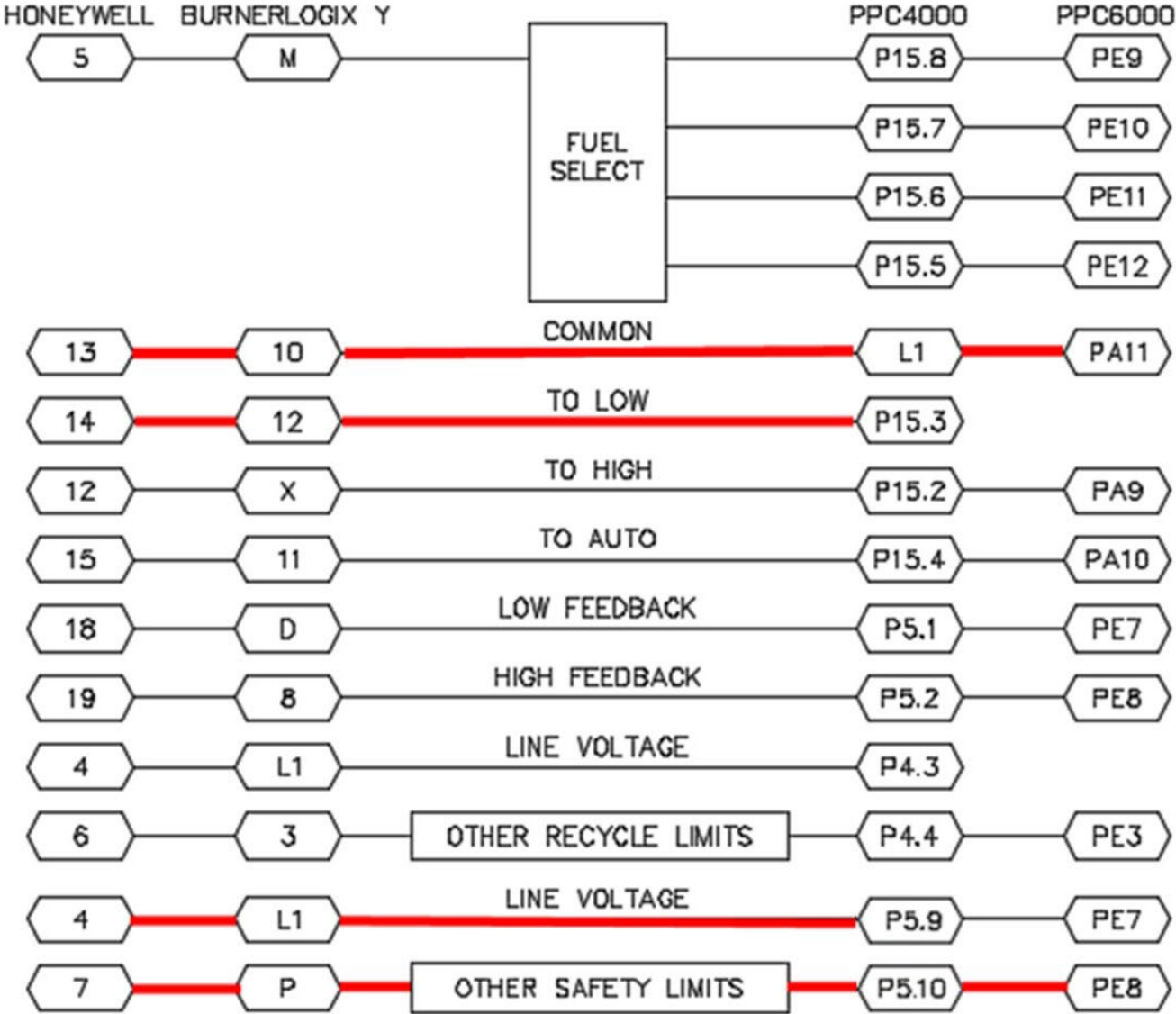
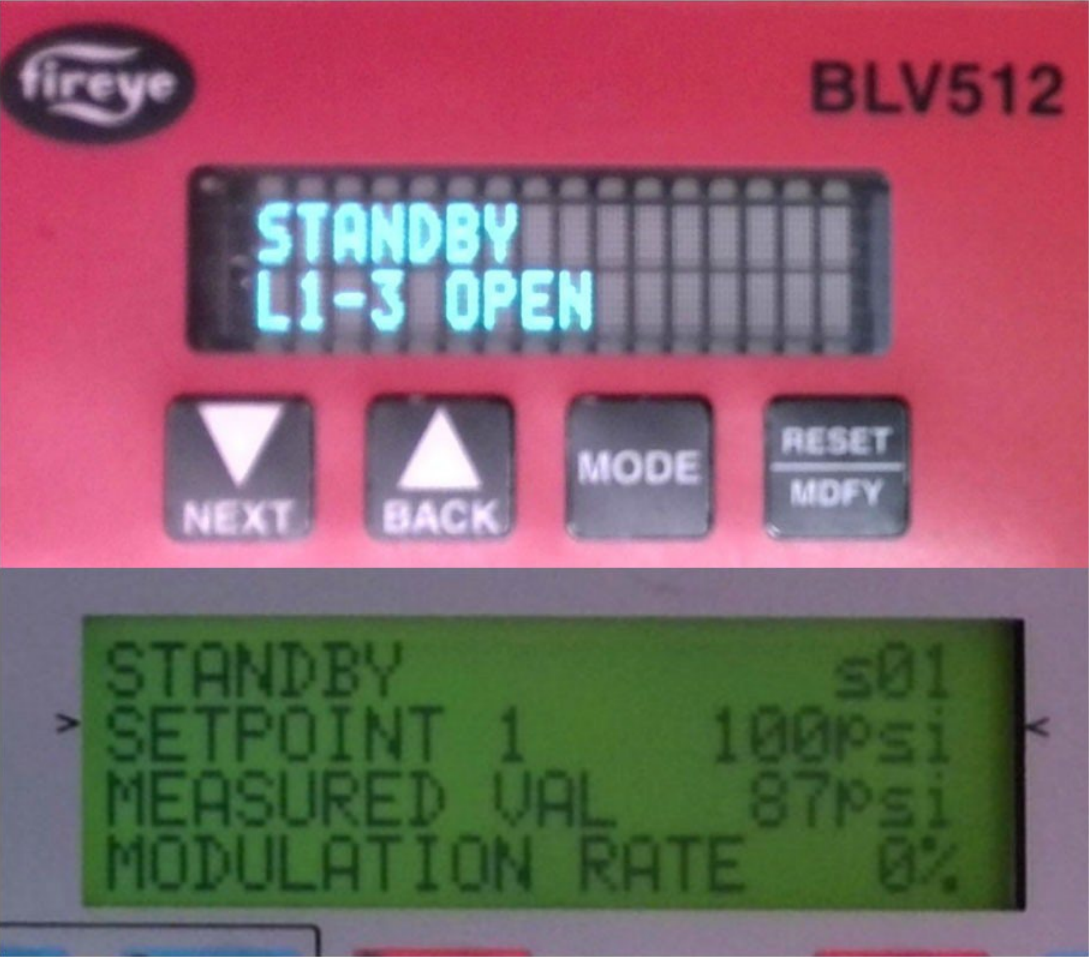

Sequence

Move to purge

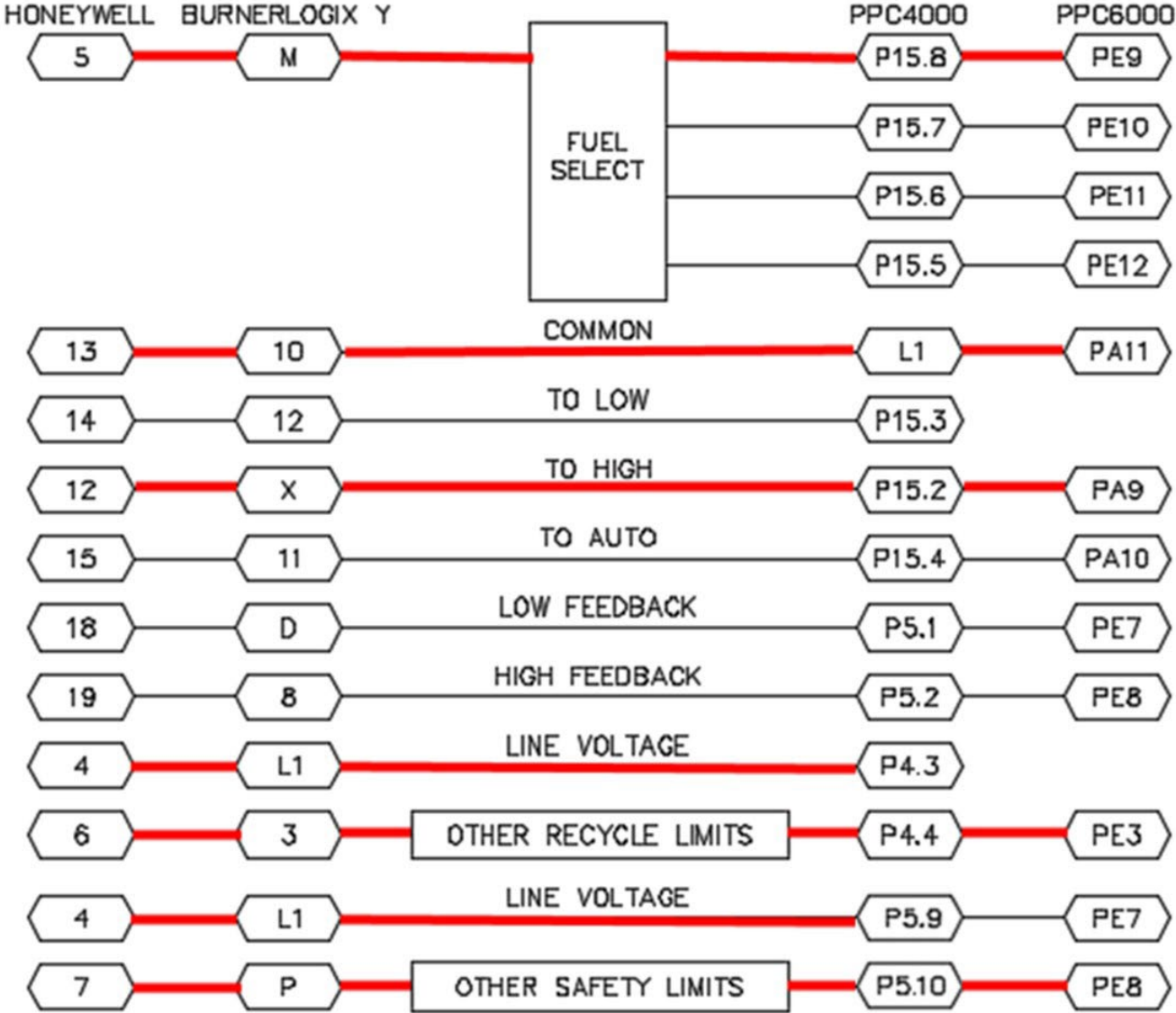
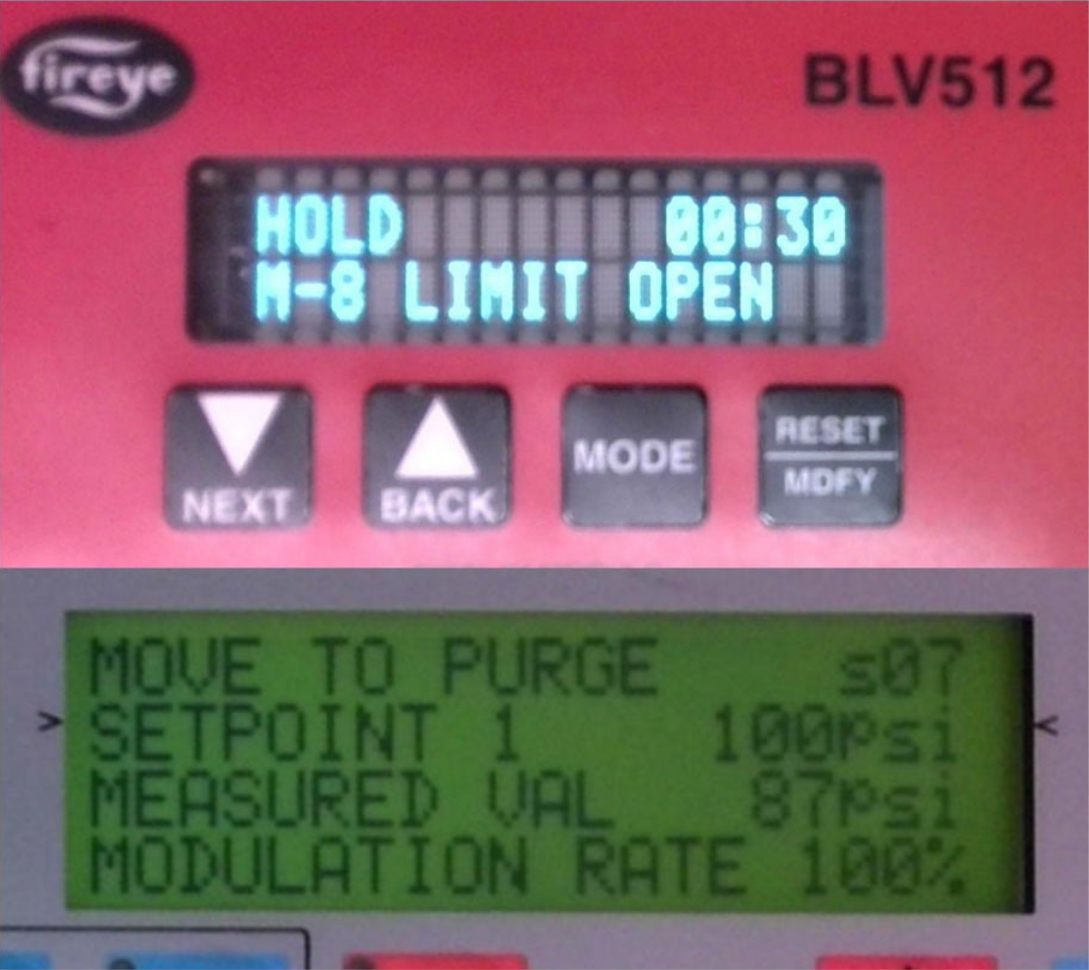

Sequence

Prepurge

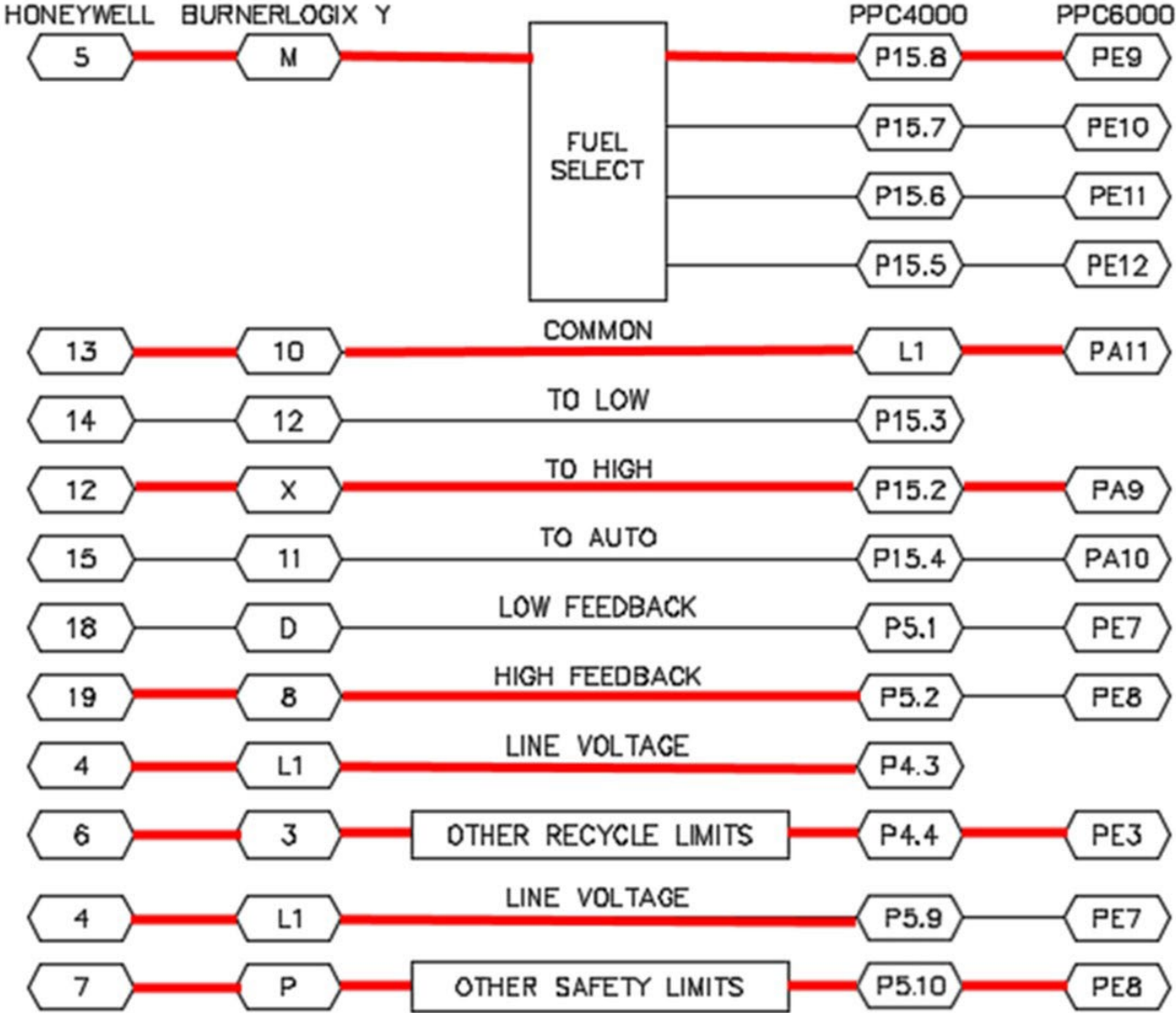

Sequence

Move to ignition

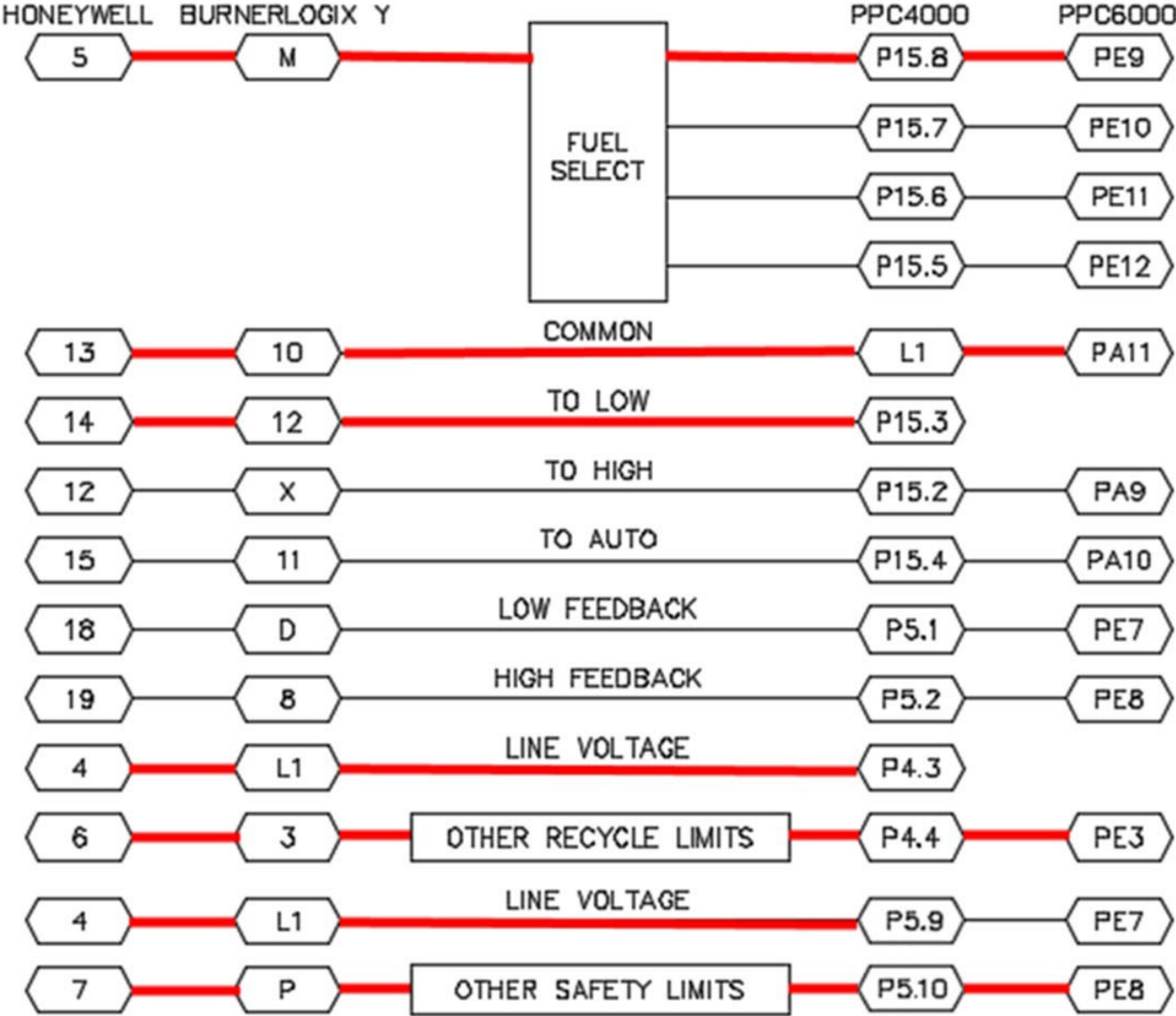

Sequence

Ignition and PTFI

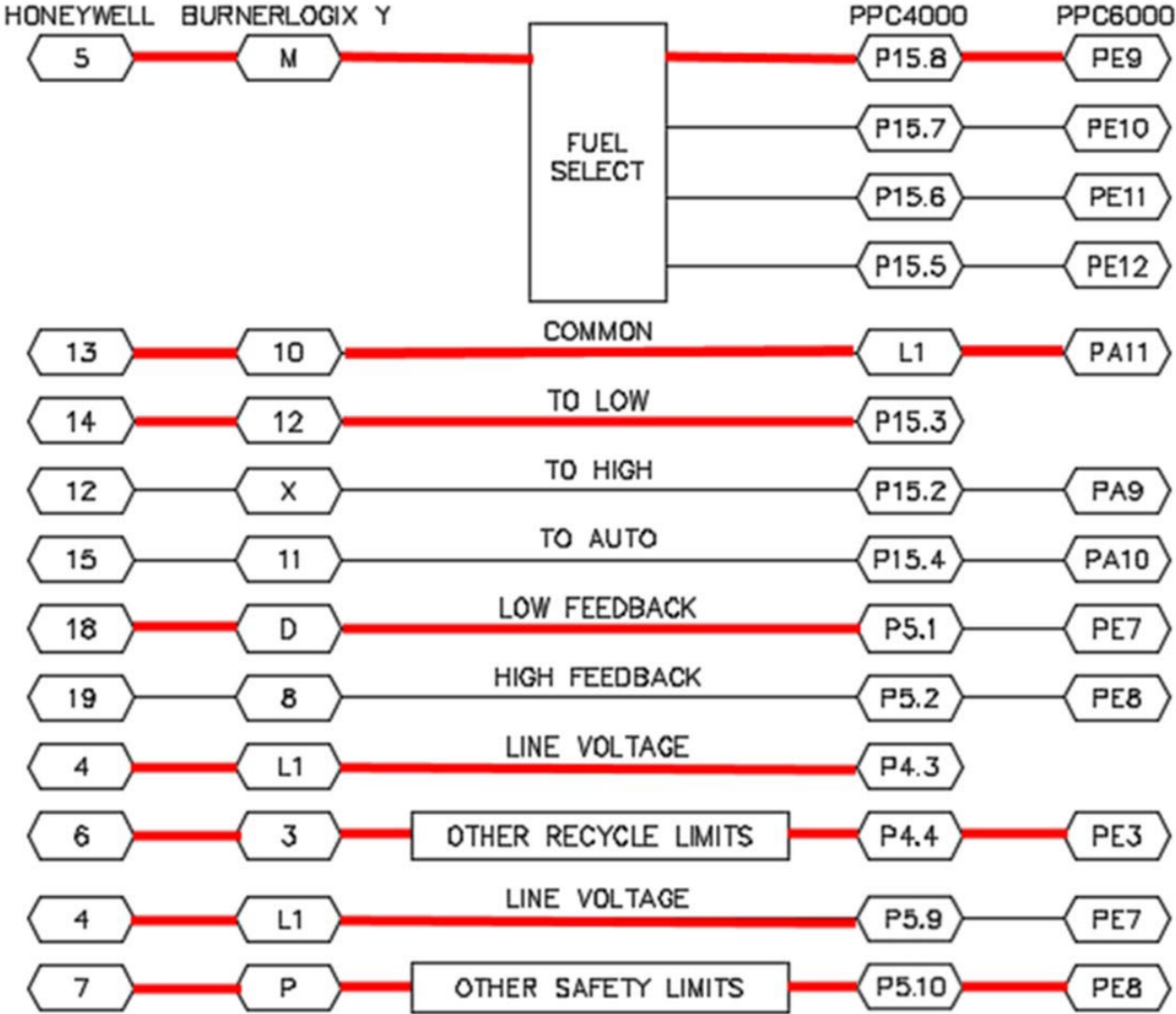
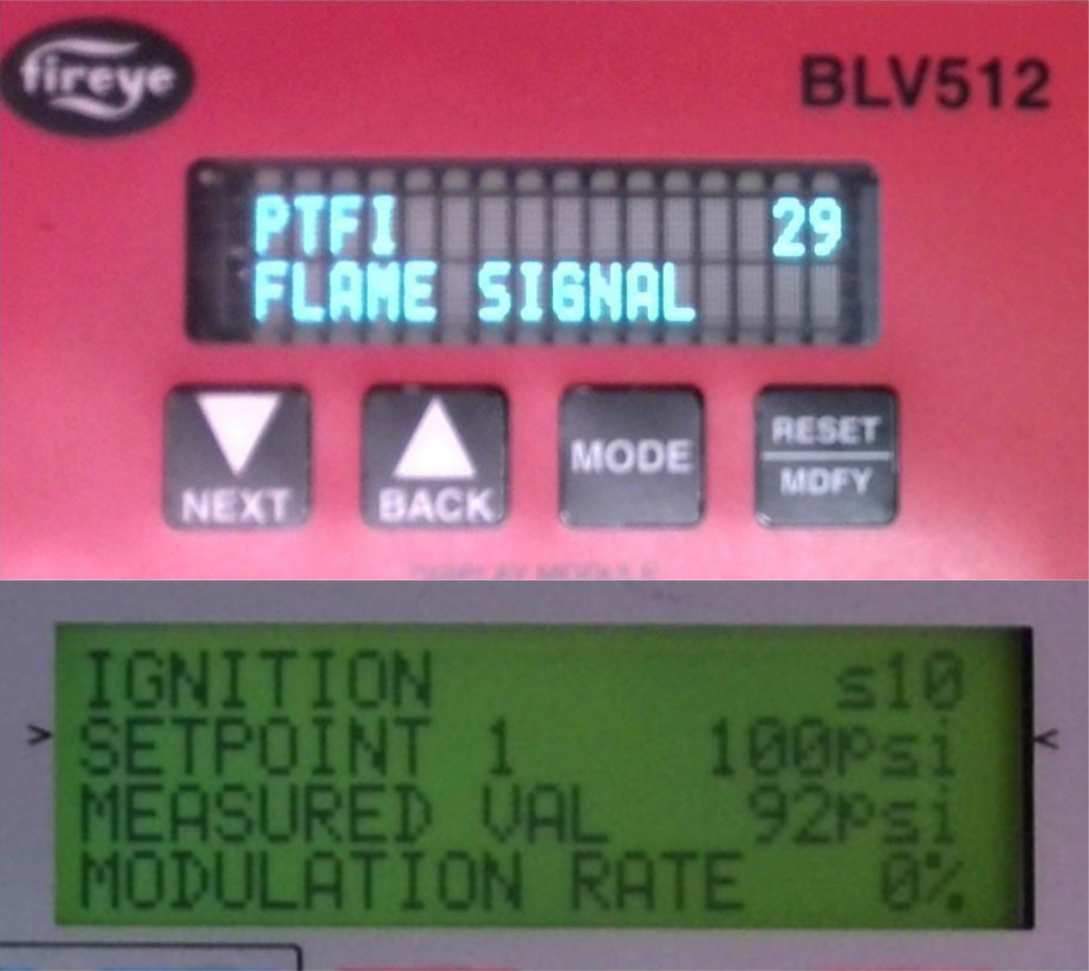

Sequence

MTFI

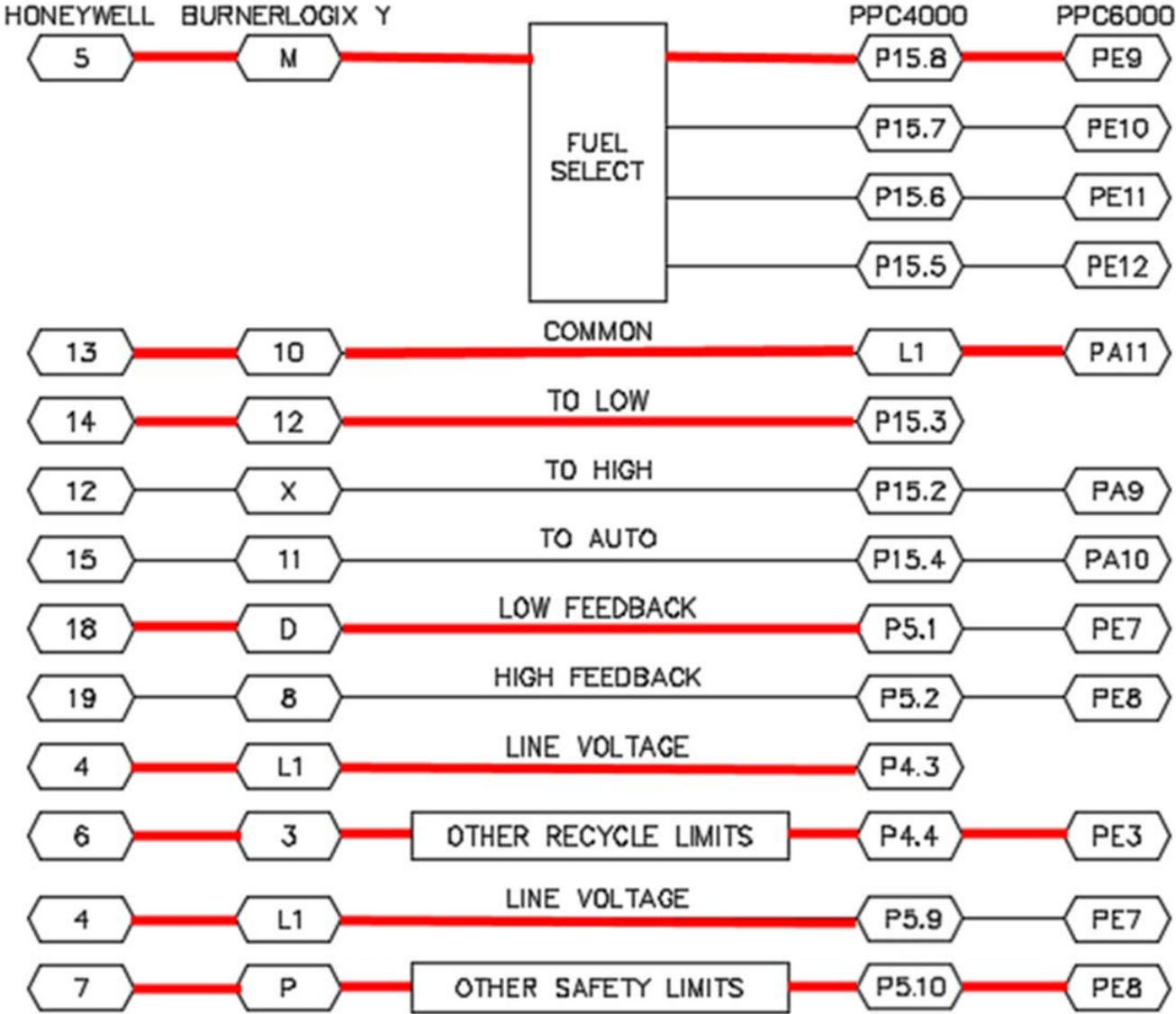
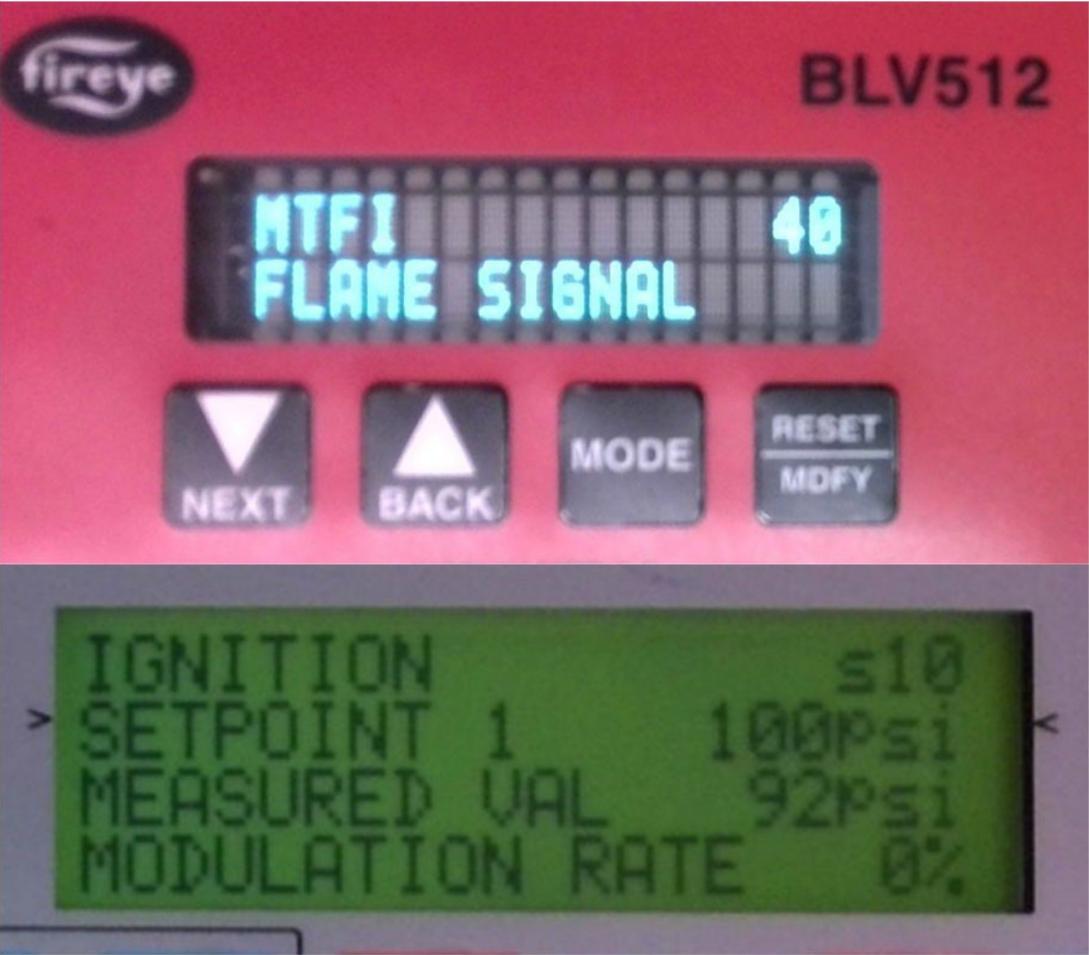

Sequence

Auto

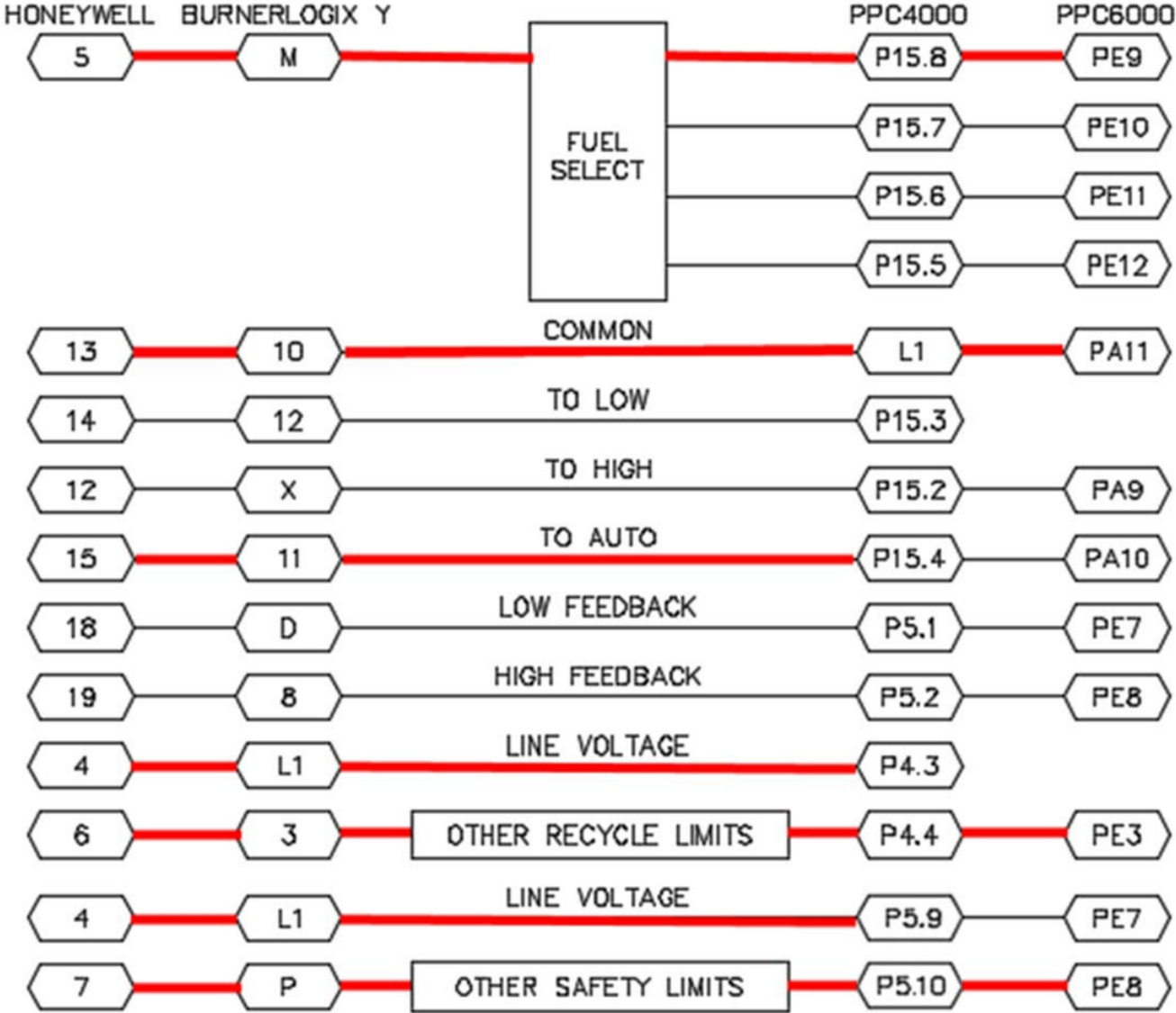
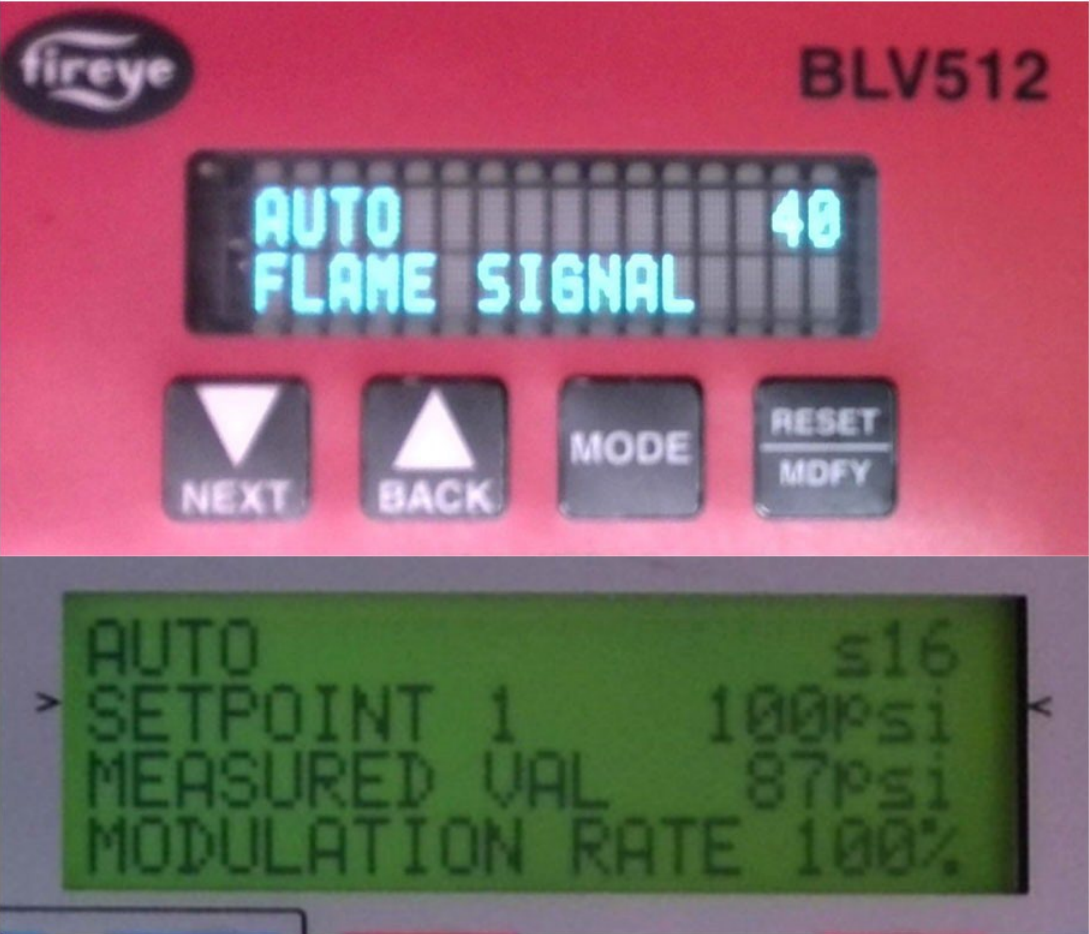

Sequence

Postpurge

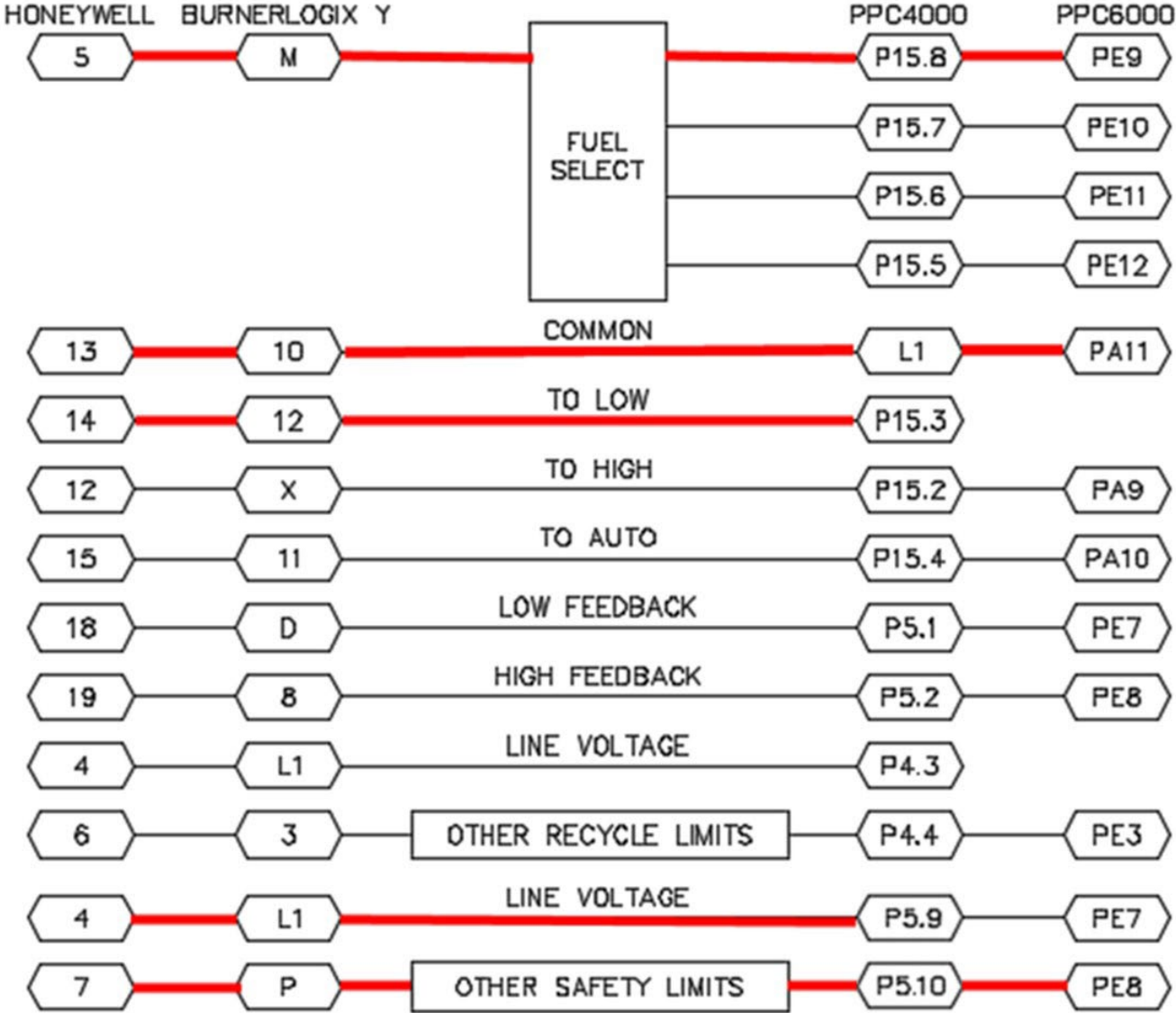

Sequence



Commissioning





THANK YOU