

# **SERVICE MANUAL**

## **FOR**

### **FLAME SAFEGUARD**

### **AND**

### **COMBUSTION CONTROLS**

**FLAME DETECTORS  
M SERIES CONTROL  
D SERIES CONTROL  
FLAME MONITOR**

by Willy Vandermeer

WV-01 - SEPTEMBER 8, 2006

***FIREYE, INC***





---

## Preface

This manual provides the basic principles of operation and application of Fireeye flame safeguard controls. It is not intended to improve on, or replace, any of the technical bulletins that are factory shipped with the controls.

Field technicians preparing for a wider base of knowledge in this field may benefit significantly from this document. Although this manual should prove beneficial at various levels, it is directed towards service technicians and operating personnel which service the equipment described in this manual on a regular basis.

However, this manual presupposes the reader possesses an adequate background in the fundamentals of burners, heaters and boilers including utilization of the various fuels burned and the control systems associated with this type of equipment.

The content of this manual outlines the Fireeye, flame safeguard (FSG) environments as well as the principles of operation and installation of the various flame detector devices and their associated control systems.







<b>Flame Safeguard</b> .....	3	<b>Common Terms In Flame Safeguard</b> .....	22
History .....	3	Prepurge .....	22
Types.....	4	PTFI .....	22
Commercial .....	4	MTFI.....	22
Industrial.....	4	Post Purge .....	22
<b>Combustion</b> .....	4	<b>Types Of Pilot Burners</b> .....	22
Burners.....	5	Interrupted Pilot.....	22
Fuels.....	6	Intermittent Pilot.....	22
Flame .....	7	Standing Pilot.....	22
<b>Flame Detection</b> .....	7	<b>Flame Safeguard Controls</b> .....	22
<b>Flame Rod</b> .....	7	Operating Interlock Circuit .....	22
Installation & application .....	9	Running Interlock Circuit.....	22
<b>Radiation Properties of Flames</b> .....	10	<b>M Series Flame Safeguard Controls</b> .....	23
<b>Visible Light Flame Detectors</b> .....	11	UVM & TFM Controls.....	23
Application & Installation .....	11	M Series II Controls .....	24
<b>Ultra Violet flame Detection</b> .....	12	Micro M Series Controls .....	26
UV Tube .....	12	M Series Wiring Schematics.....	28
Non Self-Check.....	13	M Series 100 Control Sequence.....	32
Self-Check.....	14	M Series 200 Control Sequence.....	33
Wiring UV Scanners.....	14	M Series 500 Control Sequence.....	34
<b>Infrared Flame Detectors</b> .....	15	Trouble Shooting M Series .....	35
Flame Flicker.....	15	M Series Typical Application.....	37
IR Cell Saturation .....	16	M Series Typical Application.....	38
Installation Tips .....	16	<b>D Series Flame Safeguard Controls</b> .....	39
Wiring IR Scanners .....	16	Assembly .....	40
<b>Trouble Shooting &amp; Testing of Scanners</b> ..	17	Before Installing the Control .....	40
Flame Signal Measurement.....	17	LED Indicator Lights .....	41
Hot Refractory Saturation Test .....	17	Flame Signal Strength .....	41
Hot Refractory Hold-In Test .....	17	Run Check Switch.....	41
Ignition Spark Sensing Test.....	17	D Series Wiring Schematics .....	42
Ignition Interference Test .....	18	D10/20 Series Control Sequence .....	43
Pilot Turn-Down Test .....	18	D30 Series Control Sequence .....	44
<b>Tips For Flame Detector Mounting And</b>		Trouble Shooting D Series.....	45
<b>Enclosures</b> .....	19	D Series Specifications .....	46
Flame Rod.....	19	<b>Flame Monitor</b> .....	47
Optical Detectors.....	19	Specifications.....	47
Infrared Scanners.....	19	Amplifier Modules .....	48
Ultra Violet Scanners .....	19	Programmer Modules .....	49
Swivel Mounts .....	20	Dipswitch Settings.....	50
Sealing Unions .....	20	Wiring Schematics .....	52
Purging/Cooling Air .....	20	Supply Voltage Tolerance.....	55
Enclosures .....	21	3 - P Circuit Tolerance .....	55
		Grounding Methods .....	56
		Display Module .....	58
		EPD Style Programmers.....	59
		Flame Monitor Messages .....	60
		Logic Flow Diagrams .....	62
		Trouble Shooting Flame Monitor .....	65



The control of fuel fired equipment can be divided into two categories; “Flame Safeguard Control” and “Combustion control”. Flame Safeguard Control provides operation and monitoring for safety in meeting fuel-handling and equipment design limitations. Combustion Control provides operation and monitoring for a burner’s capacity by varying its output based on process demand.

## FLAME SAFEGUARD

By definition, the term Flame Safeguard (FSG) covers all aspects of “safety” in operation of fuel fired equipment. This includes the flame detection device used to sense the presence of flame, the fuel safety shut-off valves, fuel safety limits, auxiliary safety limits, sequencing and timing relays and any other controls used in conjunction with the burner safety control system.

The main functions performed by a flame safeguard system are:

1. Safely starting and stopping of the burner either, manually, semi-automatically, or automatically.
2. Enforcing proper event-sequencing during starting and stopping.
3. Performing flame supervision via sensing and reacting to presence or absence of flame.
4. Guarding the system against conditions outside of the equipment’s design limitations.

## HISTORY

Around the turn of the 20th century, FSG was limited to mechanically shutting off the fuel in the event of a flame failure. There was no way of detecting flame, so the weight of the unburned fuel, such as fuel oil, was used as a means of detection. The fuel oil, when the flame went out ended up being collected in the furnace area, or overflowed into an exterior container, where its weight was used to cause a lever to close the fuel supply valve.

As electricity began to play a role in the industry, around the 1930’s, giving rise to electrically controlled valves, electromechanical ways of detection were also developed. Bimetal and thermocouple type instruments were developed which reacted to the temperature in flue gases or to direct radiation from the flame and many of these are still in use today.

The bimetal and thermocouple method, although suitable for low capacity applications, proved too slow for high fuel input type applications and the



**Fig. 1** Fireeye “P” Series control.  
Model: 26RJ8

search continued for faster means of flame failure detection.

It was found that a gas flame envelope could carry a small electrical current. This characteristic led to the development of a new and electronic type of flame detection. A rod (flame rod) was inserted into the flame and the conductivity of the flame, if present, could be measured. Although this system eliminated reaction time issues, it proved unreliable. Any high resistance short in the sensing circuit could also simulate flame. This was later overcome by the introduction of the “flame rectification” circuit whereby the alternating current (AC) has to be rectified to direct current (DC) in order to be accepted as flame signal. This system is still widely in use today. Both the bimetal or thermocouple and flame rod systems require direct contact with either the flue gases or flame envelope and it was not until the mid 1940’s that optical flame detection became a reality. The first optical detector was a photocell to sense visible light in oil burners, followed by infra red detectors in the 1950’s and ultra violet detectors in the 1960’s. Ongoing developments continue

to fine-tune these sensors to meet the ever-increasing demands for safety in the industry.

## TYPES

There are many types of flame safeguard controls designed for use in residential, commercial and industrial applications. Residential FSG controls generally rely on a thermocouple inserted into the pilot flame. The heat in the thermocouple generates just enough voltage to hold in a magnetic coil, which holds in a spring-loaded plunger inside the automatic gas valve allowing gas flow to the burner. The plunger is manually pushed in and the pilot lit, followed by a short period of time for the thermocouple to start generating enough current to hold in the plunger. This system requires that the pilot flame is on at all times whether the burner is on or off. As this wastes fuel, more modern residential equipment utilize an automatic pilot light on-demand via spark ignition combined with flame-rod flame detection.



**Fig 2** Burner control panel with Fireye Flame Monitor and “First-out” expansion module.

**Commercial** FSG controls are divided into “Primary” and “Programming” controls. The distinction between primary and programming is that primary controls have a minimum in operating parameter logic, such as safe start check, trial for ignition, flame failure response time and lock-out functions. This makes them ideally suitable for appliances such as small direct light-off (no pilot burner) burners and burners for make-up air heaters, direct or indirect fired.

Programming controls operate with many additional functions such as pre-purge, proof of

purge, low fire start, check fuel-valve closed, post-purge and other functions.

Both residential and commercial FSG products are designed with single burner appliances such as furnaces and boilers in mind. These appliances require that the flame safeguard control properly sequences the operation of the burner system: energizing the combustion air blower motor, purging the combustion chamber of any combustibles, opening pilot fuel valve and energizing ignition, establishing main flame and monitoring flame for failure. All components must be energized in the proper sequence to prevent unburned fuel from accumulating in the equipment where it could cause a hazardous condition. It continuously senses presence or absence of flame while controlling the operation and sequence of all components on the burner in the proper order.

**Industrial** FSG controls generally operate in a multi burner environment. This environment places different demands on flame safeguard controls, the most important of which is the ability of the flame detection system to discriminate between its targeted flame and other flames sharing the combustion chamber. Programming and sequencing logic in a multi burner appliance generally resides in a burner management system (BMS) which may be in the form of a programmable logic controller (PLC) or a relay logic panel, or a combination of both. A separate Fireye bulletin “Flame Safeguard Controls in Multi Burner Environments”, publication WV-96, deals with this subject in detail.

## COMBUSTION

Combustion or burning, is a rapid combination of oxygen with fuel, resulting in release of heat. The oxygen comes from air. Air is about 21% oxygen and 78% nitrogen by volume. Most fuels contain carbon, hydrogen, and sometimes sulfur. A simplification of combustion could be listed in the following three processes:

carbon + oxygen	=	carbon dioxide + heat
hydrogen + oxygen	=	water vapor + heat
sulfur + oxygen	=	sulfur dioxide + heat

The above three products of combustion are chemical compounds. They are made up of molecules in which elements are combined in certain fixed proportions. As per the law of science, matter is neither created nor destroyed in the process of combustion, and the heat given off in any combustion process is merely excess energy which the molecules are forced to liberate because of their internal make-up. Stoichiometric combustion is obtained when no fuel or air goes unused during the combustion process. Mixing and burning exactly the right proportions of fuel and oxygen so nothing is left over does this. Combustion with too much (excess) air is said to be lean or oxidizing. The excess air or oxygen plays no part in the combustion process. In fact it reduces the efficiency. The visual effect is a short and clear flame. Combustion with too much fuel is said to be rich or reducing, producing incomplete combustion. The visual effect is a long and sometimes smoky flame. The oxygen supply for combustion generally comes from the ambient air. Because air contains primarily (78%) nitrogen, the required volume of air is generally much larger than the required volume of fuel. Primary air is air that is mixed with the fuel before or within the burner's fuel delivery system. Secondary air is usually brought in around the burner's fuel delivery system and spun through a diffuser or turning vane system in order to optimize air-fuel mixing. Tertiary air is air brought in downstream of the secondary air and is sometimes used to control the shape of the flame envelope, and/or to control flame temperature on low-NOx burners.

**BURNERS**

Burners are a simple device to convert fossil fuels into useable heat energy. The primary functions of burners are:

- a) Controlled fuel delivery.
- b) Controlled combustion-air delivery
- c) Controlled fuel and air mixing.
- d) Controlled and reliable ignition.
- e) Evacuation of products of combustion.
- f) Controlled emissions.

Regardless of fuels fired, burners must reliably perform all functions. Choices of fuels burned and type of burner affect the difficulties in

achieving optimum results in any of these functions. The following lists some variations of burner types found:

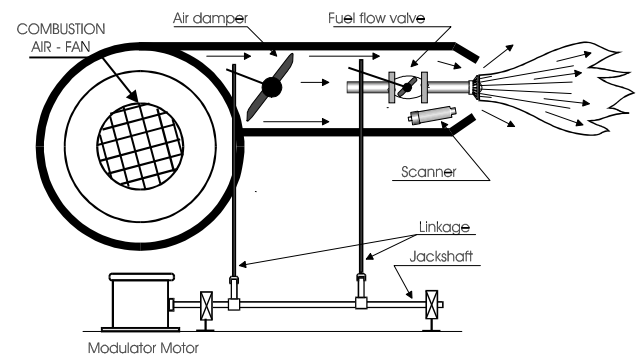
- a) Gaseous fuel fired:
  - a) Natural draft burner
  - b) Inspiring burner
  - c) Balanced draft burner
  - d) Induced draft burner
  - e) Forced draft burner

Liquid fuel fired: (forced or balanced draft)

- a) Mechanically atomized.
- b) Air atomized
- c) Steam atomized

Final fuel delivery and combustion-air & fuel mixing varies dependent on the burner types as per the following examples:

- a) Gun type (gas or oil)
- b) Cane (spud) type (gas)
- c) Ring type (gas)
- d) Rotary cup type (oil)



**Fig. 3** Principle parts of a forced draft burner.



**Fig. 4** Forced draft burner.



A burner must be equipped with a monitoring and control system to assure safe and reliable operation throughout its intended use. Complexity of this system is in relation to complexity of the process at hand and can vary from a single burner firing a single fuel, to a multi burner environment where many burners are operating into a common combustion chamber and a multiple choice of fuels are burned. The larger the burner input, or heat release of a burner, does not necessarily mean the more complex the monitoring and control system needs to be.

Conditions effecting complexity of control systems for burners are generally stipulated by:

- a) Type of process.
- b) Type of burner.
- c) Multi or single burner environment.
- d) Multi or single fuel operation.
- e) Safety hazard of fuel burned
- f) Local codes and standards.
- g) Redundancy and reliability factors.
- h) Continuous or intermittent burner operation.

Technological advances in recent years in particular microprocessor based hardware, has made it important that only qualified technicians are employed in the application of instrumentation hardware used in today's burner operating and safety systems. Components making up the system for monitoring and control of burners are subject to standards set by local authorities.

**FUELS**

Most fuels are mixtures of chemical compounds called hydrocarbons. When burning these fuels, the final products contain carbon dioxide and water vapor unless a shortage of oxygen exists in which case the products of combustion may contain carbon monoxide, hydrogen, unburned hydrocarbons and free carbon. Heat available from fuels is measured in Btu/lb or Kcal/kg (Btu/gal or Kcal/l for fuel-oil). Natural gas fuel is the most straightforward fuel to use. It requires no special handling in filtering, drying, heating, etc. On the other hand, the efficiency in utilization of fuel oils depends to a large extent upon the ability of the burner system to atomize the oil and mix it with combustion-air in the correct proportions. Heavy fuel oils are usually pre-heated with steam. Tank heaters may raise heavy fuel-oil temperatures sufficiently to reduce

its viscosity in order to facilitate pumping and straining.

Fuel Burned	Btu/Lb (Btu/Gal)		Kcal/Kg (Kcal/L)	
	Gross	Net	Gross	Net
Blast furnace gas	1,179	1,079	665	599
Coke oven gas	18,595	16,634	10,331	9,242
Natural gas	21,830	19,695	12,129	10,943
Propane gas	21,573	19,886	11,986	11,049
Oil #2	18,993 (137,080)	17,855 (128,869)	10,553 (9,130)	9,920 (8,583)
Oil #6	18,126 (153,120)	17,277 (145,947)	10,071 (10,198)	9,599 (9,720)
Coal	14,030	12,900	3,500	3,100

**Table 1** Comparative heating values for typical fuels.

In order to burn a liquid fuel, most burners atomize the liquid. Atomization is the formation of the smallest possible droplets. This is required in order to expose as much surface area of the fuel as possible within the flame envelope. Steam atomization can be accomplished by projecting steam tangentially across jets of oil at the oil nozzle, resulting in a conical spray of finely divided oil after the mixture leaves the nozzle. Air atomization is accomplished by using air as an atomizing agent in an arrangement such as a proportioning inside-mixing-type oil burner using low-pressure air as an atomizing agent. Large capacity oil burners use two steps to get the oil combustible: atomization and vaporization. Vaporization converts oil from the liquid to the Vapor State by application of heat at the flame-front. By first atomizing the oil into millions of tiny droplets, the exposed surface area is increased many times and the oil can vaporize at its highest rate. For good atomization and vaporization, a large volume of air must be initially mixed with the oil particles. Mechanical atomization - atomization without the use of either air or steam - is synonymous with pressure atomizing. The nozzle used in mechanical atomizing consists of

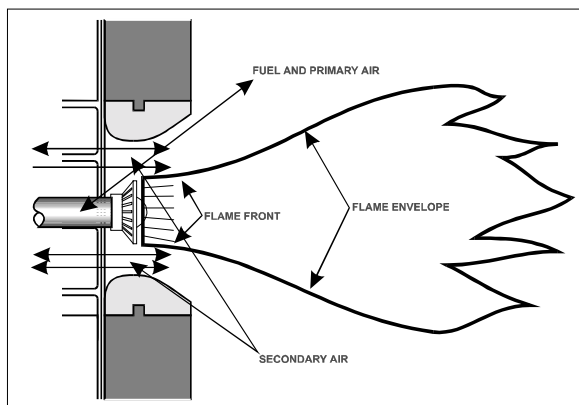


a system of slots tangential to a small inner whirl chamber followed by a small orifice. In passing through the slots, the liquid volume is increased. The high velocity prevailing in the whirl chamber in a tangential direction imparts a centrifugal effect that forces the oil against the walls of the nozzle. It then passes through the orifices in the nozzle tip and into the combustion chamber, fanning out into a cone shaped spray of very small particles.

## FLAME

A flame is merely a zone within which the combustion reaction takes place at a rate that produces visible radiation. A flame-front is the contour along which the combustion starts (the dividing line between the fuel-air mixture and the combustion process). In stable flames, the flame front appears to be stationary. The flame is actually moving towards the burner-nozzle(s) at the same speed that the fuel-air mixture is leaving the burner. Wide ranges of feed rates exist in a wide range of burner designs. In order to select the most suitable flame detection hardware, it is necessary to know the basic characteristics of flames. The combustion process actually is surprisingly complicated, yet it is only required to understand a few of the general characteristics of flames to assist you in selecting the best detector for the job. Common flame characteristics are:

- Production of heat energy.
- Expansion of gases.
- By-product production.
- Radiation emission.
- Ionization within the flame envelope.



**Fig 5** *Flame envelop*

## FLAME DETECTION

Heat energy from a flame has not been found to be suitable for flame detection. Sensors used to detect the presence or absence of heat given off by the flame do not respond fast enough. Additionally, the need to directly insert a sensing device into the flame to detect the targeted flames' heat energy would make such a system subject to high maintenance.

Expansion of gases as a fuel-air mixture burns can be detected and used as flame detection. It is not a useful system for main burner flame detection. In a multi-burner environment it is sometimes seen in igniter-flame detection. As this system requires the detection of relatively minute changes in pressures at the burner nozzle, it deals with tubing which run from the burner nozzle back to delicate pressure measuring devices, these systems also are subject to high maintenance to keep them operative.

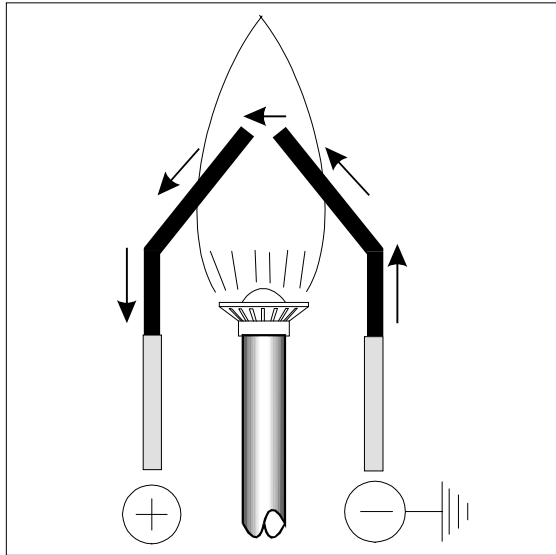
Production of by-products, chemically is a reliable source to detect whether or not combustion is taking place. But, as with heat energy, response time would be too slow, and the detection of an individual flame in a multi-burner furnace extremely unlikely.

Emission of radiation by the flame, and ionization within the flame-envelope are the two most commonly used flame characteristics used in FSG flame detection hardware. In industrial FSG systems, emission of radiation is used for main flame detection by means of optical flame detectors. Ionization, by means of a flame rod, is generally used for detection of a gas-igniter flame. Commercial and light industrial FSG systems may at times apply a single detector to detect both main and igniter flames.

## FLAME ROD

Flame ionization is the process of heat in the flame causing the molecules in and around the flame envelope to collide with one another with sufficient force to free some of the outer electrons of the atoms that make up the molecules. In this way, free electrons and positive ions have been created. This ionization process allows a very small current to be conducted through the flame. Flame conductivity is low. Resistance can vary from 100,000 to 100,000,000 ohms. Current conducted through the flame (flame current) is generally in the range of 2 - 4 micro-amps. If two

electrodes were placed in a flame and a voltage was applied, a current would be conducted between the two rods (flame rods). Naturally the positively charged ions would flow to the negatively charged rod. In order to use this process to determine presence of flame and to prevent the potential hazard of a high resistance short to ground effectively simulating flame signal, the flame current is rectified.



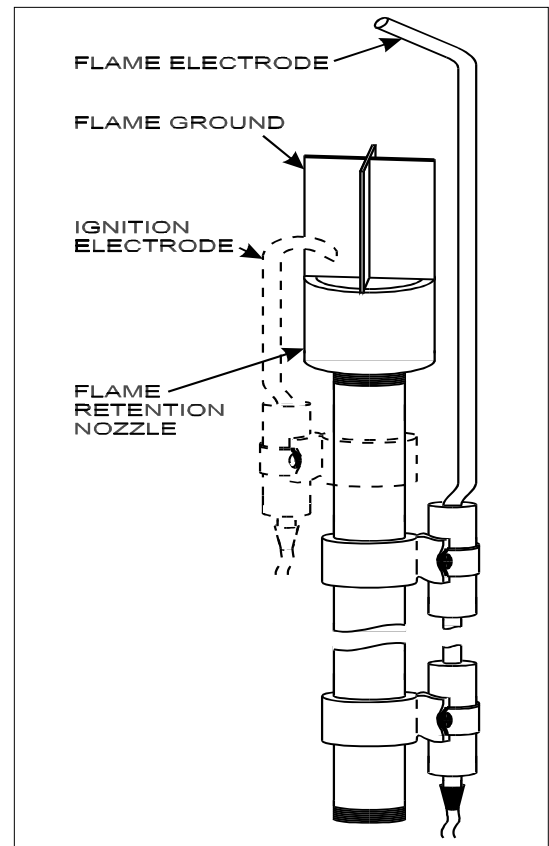
**Fig. 6** Electron flow through ionization within the flame envelop.

Generally referred to as a Flame Rectification System, it is achieved by placing a grounding electrode in the flame that is several times (generally 4 times) larger than the flame rod or electrode. An AC supply voltage is applied across the electrodes. During half of the AC cycle the flame rod is positive and the ground rod is negative. The positively charged ions will flow to the negatively charged grounding area. As the grounding area is larger, its capacity to hold electrons is increased, resulting in a relative high flame current flowing through the flame during this first half cycle. During the second half cycle, the reverse process will take place. However, the capacity of the flame rod to hold electrons is less than the grounding area and the resulting flame current is smaller. The greater the ratio of grounding area to flame rod area, the greater the rectified current. The only accepted type of current by the system is this rectified flame current. Any high resistance type short circuit will result in an AC type flame current, which is rejected by its FSG control.

The large grounding electrode generally forms part of the burner's fuel-nozzle, helping to stabilize and hold the flame firmly in place. Flame rods are simply small diameter metal rods supported by an insulator in order to be able to mount it such that the tip-end of the rod can project into the flame. Flame rods typically are made of a material called Kanthal, a high temperature alloy capable of operating in temperatures of up to 2400 degree F. or 1300-degree C. Other materials for even higher temperature ratings such as Global, a ceramic material, are also available.

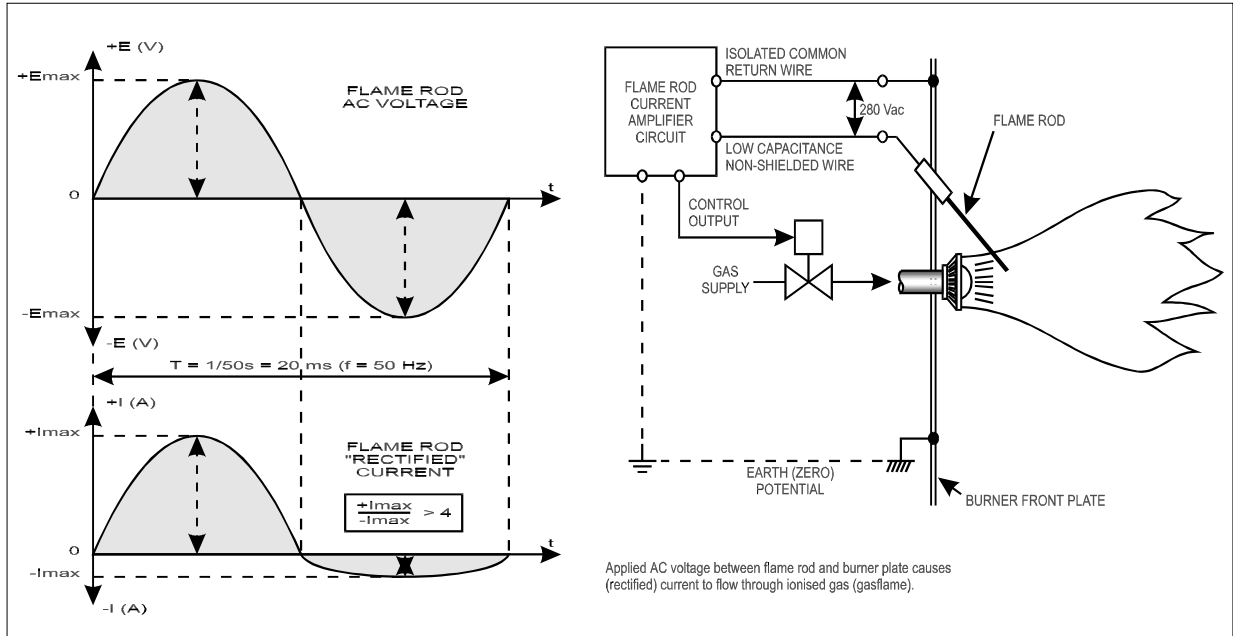
Requirements for successful flame rod applications are:

- Stable flame. (no movement from flame rod)
- Gas burners only, premixed were possible.
- Adequate flame-rod-to-grounding area proportioning. (4 to 1 minimum).
- Proper placement of flame rod in flames (short as possible, yet adequate contact).
- Proper rectifying flame current and associated circuitry.



**Fig. 7** Typical pilot burner assembly with flame-rod flame detection.





**Fig. 8** Flame-rod system operational diagram.

Advantages of flame rod applications:

- a) Location sensitive. Flame rod detectors prove the flame with extreme location sensitivity. The flame must be where the relative small rod can be in contact with it. This is most useful in controlling for example, that a pilot flame is detected only when it is at the optimum location to reliably ignite the main burner. Flexibility in placing the rod can assure this. Also, this location sensitivity will detect flame lift-off and as such can be used to prevent unstable flame conditions for both pilot and main flames.
- b) Fast response time. The relative low cost flame rod system has been put to use replacing many, and sometimes working as an auxiliary to, slow responding bi-metal and thermocouple based systems.
- c) Fail-safe system. Using electronics, this system responds safely to abnormal conditions such as open or short circuits, leakage to ground, all causing the system to fail-safe.

Ideally, the flame rod is mounted vertically alongside its vertical burner nozzle with only the tip bent in to make contact with the flame envelope. When installing a flame rod on a horizontally orientated burner assembly, care must be given to favor installing the rod on either one of the sides of the burner or directly below, with the tip bent up to make contact. Installing

the rod directly above the burner assembly is least favored as this may allow it to prove a lazy upward bending inadequate flame.

Some atmospheric burner assemblies use a runner type pilot, a pilot that is used to light off more than one burner. It may consist out of a tube with holes drilled along its side through which fuel gas is burned. An assembly such as this requires it to be proven at its ignition source and also at the extreme end of the runner pilot. A thermocouple may be used to prove the pilot at the ignition source and a flame rod may be used to prove it at its extreme, with the flame rod system in charge of main fuel.

On some direct fired air handling units burners are installed which are of significant length requiring the main flame to be detected at the end farthest away from the ignition source. This also has proven to be an ideal job for flame rod systems.

**INSTALLATION AND APPLICATION**

The Fireye part number 69ND1 flame rod is a spark plug type unit consisting of 1/2" NPT mount, a Kanthal flame rod, a glazed porcelain insulating rod holder and a spark plug connector for making the electrical connection. The 69ND1 is available in 12", 18" or 24" lengths.



The flame rod may be located to monitor only the gas pilot flame or both the gas pilot and main gas flames. It is mounted on a ½" NPT coupling.

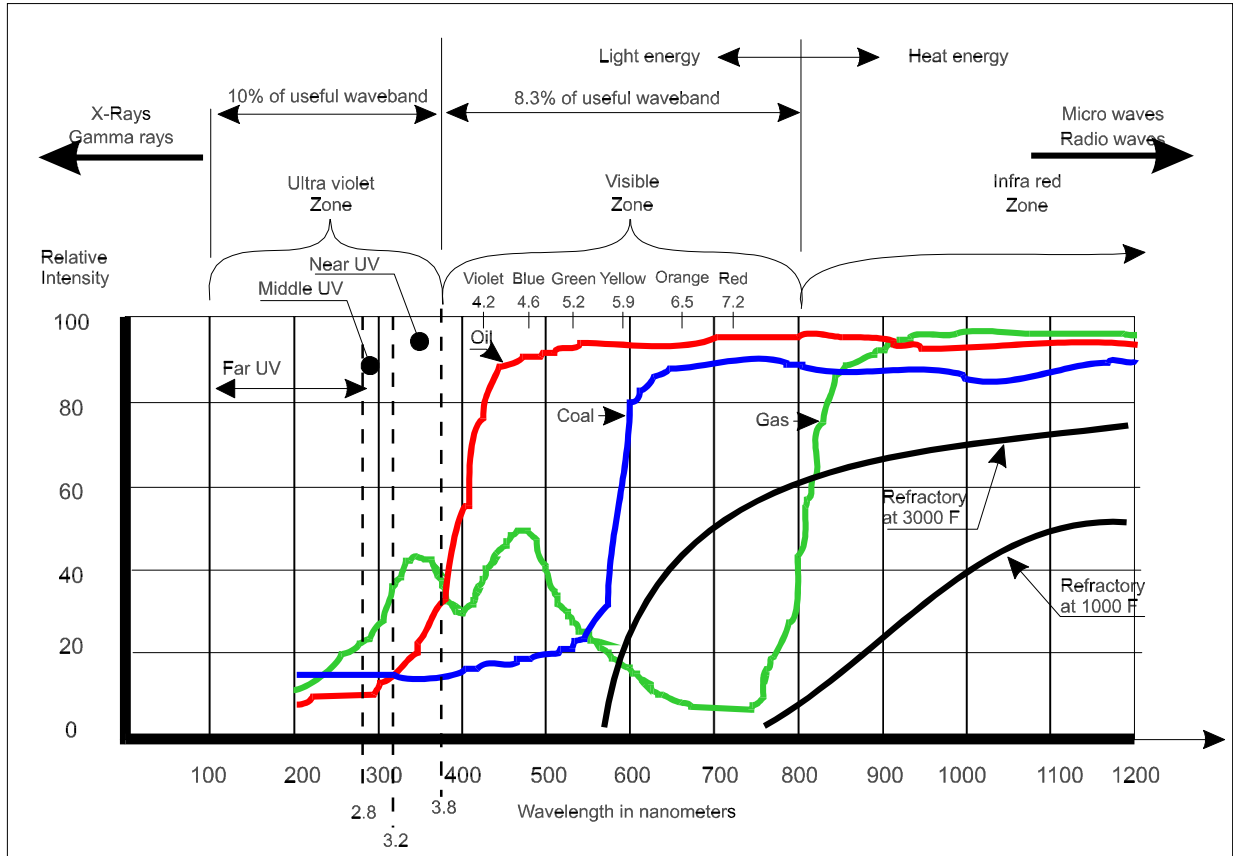
The following installation instructions should be observed:

1. Keep flame rod as short as possible.
2. Keep flame rod at least ½" from any refractory.
3. Flame rod should enter the pilot flame from the side so as to safely prove an adequate pilot flame under all draft conditions.
4. If the flame is nonluminous as with premixed burners, the flame rod tip should extend at least ½" into the flame, but not more than half way through.
5. If the flame is partly luminous, the flame rod tip should extend only to the edge of the flame. It is not necessary to maintain absolutely uninterrupted contact with the flame.
6. It is preferable to angle the rod downward to minimize the effect of sagging and to prevent it from coming into contact with any object.
7. An adequate grounding surface for the flame must be provided. The grounding surface in actual contact with the flame must be at least four times greater than the area of the portion of the flame rod in contact with the flame. It is essential to adjust the flame rod and ground area ratio to provide maximum flame signal reading.
8. Interference from the ignition spark can alter the true flame signal reading by adding to, or subtracting from it. Interchanging the primary wiring (line voltage) to the ignition transformer sometimes may reverse this trend. This interference can also be reduced by the addition of grounded shielding between the flame rod and ignition spark.
9. Proven types of flame grounding adapters may be used to provide adequate grounding surface. High temperature stainless steel should be used to minimize the effect of metal oxidation. This assembly may weld directly over the pilot or main burner nozzle.
10. Use the proper wire and wiring techniques. No. 14 wire, rated at 90 C or higher is recommended for control to flame rod. Actual wire size is not critical. Increased resistance that occurs with smaller wire size will not be of significance. Type of insulation is important. Use wire with the highest leakage resistance to ground. In practice

wire runs can be up to 200 feet long. Do not share the flame rod wire with ignition wires in same conduit.

## RADIATION PROPERTIES OF FLAMES

Emission of radiation from within a flame is the most widely used media for flame detection. The radiation properties of the flame are utilized to operate electronic optical flame sensing devices. Electronic sensing is required to achieve the quick flame-failure-response-time (FFRT) demanded by larger input appliances. Depending on type of fuel burned and rated input capacities, FFRT is generally from one (1) second to four (4) seconds. Flames emit radiation along a wide band of the flame's electromagnetic spectrum, which is called the flame spectrum. The flame spectrum is made up of ultra violet, visible, and infra red radiation. Ultra violet and infra red radiation are at the opposite extremes of the flame spectrum with only wavelengths of 400 to 800 nanometers visible to the human eye. The blue visible light is towards the ultra violet, and the red visible light is towards the infra red portion of the spectrum. Flame detectors are designed sensitive within either ultra violet, visible or infra red radiation. Various aspects determine the proper selection of flame detector type. Ultra violet, (at about one percent) is the least available of the three types of radiation from a flame. Generally, the first 1/3 of a burner flame is the main source of ultra violet radiation. High temperature flames give of high amounts of UV radiation. Both oil and gas flames radiate sufficient UV for detection. Visible radiation amounts to ten percent of total radiation and is detectable by the human eye in the various colors: blue with orange yellow for gas flames and bright yellow for oil and powdered coal flames. Infrared is emitted at about ninety percent of total radiation emitted by burner flames and is found mostly in the last 2/3 of the flame. Hot furnace parts such as refractories emit IR radiation when above 1000 F.



**Fig 9** Radiation characteristics for common fuels.

**VISIBLE LIGHT FLAME DETECTORS**

Detection of flame by seeing its visible light is the way man detected flame since it was first observed. There are two standard detectors used for sensing flame in the visible region; a photo-emissive cell (photocell) and a cadmium sulfide cell (cadcell). A photocell device is a glass-enclosed structure (tube) which has been completely evacuated. There are two elements within the tube, a thin metal plate that acts as the cathode and a collector wire assembly, which acts as the anode. When light strikes the cathode, electrons are emitted which are drawn to the anode. The current in this type of tube is very small and requires considerable amplification before it can operate a relay. Photocells are of the rectification detector type, where AC voltage is applied, but the operation of the electronic system depends on DC voltage. It is the job of the photocell to allow current flow and to convert alternating current to direct current when sensing flame. A cadcell device is a small device that is constructed from an

insulating plate covered with a deposit of cadmium sulfide that is mounted in a protective enclosure covered by a glass window. This device acts like a resistor, which is sensitive to light. When the cell is in the dark, the resistance of the element will be high (>50K ohms). When exposed to light (from a flame) the resistance will drop to a few thousand ohms, and enough current will flow to pull in a relay without further amplification. Flame detectors that operate in the visible region will also operate from other light-sources such as daylight or light from lamps. It is therefore necessary to make sure that they are used only in locations where they cannot be exposed to other sources of light. Visible light from hot refractory may also activate these sensors.

**APPLICATION / INSTALLATION**

Visible light flame detectors are used primarily in commercial and/or industrial oil-fired burners. Generally, they are not applied to gas burning equipment as a well-adjusted gas flame gives off

insufficient visible light for detection. In applying these detectors, special attention must be given to:

- 1) As with all optical detectors, the cell must have full view of the flame monitored.
- 2) Care should be given to protect it from possible visible light emitted by hot refractory or other sources.
- 3) The detector must be protected from ambient temperatures in excess of 165 F (74 C).
- 4) Proper wire must be used to connect the detector. Temperatures above 125 F (52 C) may require specially protected wiring.

### ULTRA VIOLET FLAME DETECTION

Flame scanners operating in the UV wavelength may utilize an ultra violet detection tube. In this type of system, when UV radiation is detected, the flame is considered present. Differentiation or discrimination between the targeted flame and neighboring flames or background is achieved by means of discriminatory scanner sighting. This means seeing as little as possible of the background, combined with signal sensitivity adjustment or threshold settings to tune out unwanted signal at the detector's controller. UV detection tubes should be sensitive only in the far UV wavelength range, 200 to 300 nanometers to be considered solar blind. Solar blindness is important in prevention of the detector picking up stray light from sources other than the flame spectrum.

UV detection tubes are made of quartz, the tube is sealed and filled with gas. It contains two electrodes connected to a source of AC voltage. When ultra violet radiation of sufficient strength falls upon the electrodes, electrons are released and the gas within the tube becomes conductive through ionization resulting in an electric current flow from one electrode to the other (cathode to anode). A relative high AC voltage (400 to 1200 VAC) is applied to the electrodes, resulting in the tube producing an arc between the electrodes when sufficient UV radiation is present to produce the required ionization of the inter-electrode gas. The tube is said to be "Firing". By design, this "arc" wanders back and forth along the electrodes, never staying in one place, thus preventing damage to the electrodes by over-heating. A quartz lens is needed to focus the UV radiation directly on the detector

tube electrodes. Generally the voltage supplied to the tube is AC. (DC voltage may also be used along with a square pulse generator). Voltage across the electrodes will go to zero for each half cycle of AC, allowing the tube to restore itself to a non-ionized or quenched state. On the next voltage half cycle the current is re-established across the electrodes in order to fire if UV radiation is present.



**Fig. 10** UV radiation detection tube. Fireye part no: 4-320

The amount of firings during each cycle is known as the count. The maximum counts of firings during one second is the number of counts during one half cycle, times twice the frequency of the supply voltage. (See figure 12) When flame is present and UV radiation enters the tube, the system begins to count. When the flame disappears, UV radiation stops and the system stops counting. A flame relay is part of the system. An electronic circuitry receiving the count signal from the detector pulls in the flame relay, which remains in as long as its pre-set threshold is satisfied.

The count is directly related to the intensity of the UV radiation; a very intense source of UV radiation may produce several thousand counts per second. As such, the count is a measure of flame intensity. Upon disappearance of flame,

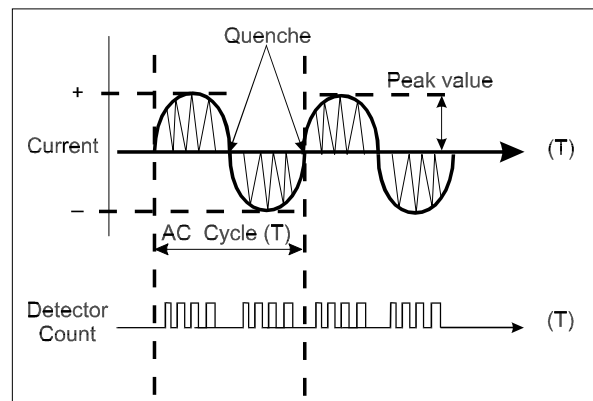
the detectors' count goes to zero except for very infrequent firings, inherent in this type of design, to which the system does not respond. UV flame detectors are designed to respond to UV sources in a flame, however it is possible for the detector to respond to other sources of UV radiation such as: Hot refractory well above 3000 degree F, also spark-ignition, welding arcs, halogen light, etc. Care should be taken to avoid picking up unwanted signal from any of these sources at, or near the burner-front. Ultra violet detection tubes can deteriorate due to degeneration of the special gas inside the tube. The cause of this could be over-heating the tube, subjecting the tube to excessive voltages or subjecting the tube to excessive UV radiation for long periods of time. Tubes deteriorated in this way can operate in a random failure mode; sometimes firing continuously after having started and failing to quench, or sometimes firing inconsistently causing nuisance shutdowns.



**Fig. 11** UV Flame scanner, non self check.  
Fireeye part no. UV1A

Tubes can also fail in a way that it causes the tube to fire as soon as the normal operating current is applied regardless of presence of UV radiation. Any flame safeguard system will pick-up a faulty UV detection tube during start up and no flame or signal should be present. The system will perform a "Safe Start Check" as first part of its sequence. A system lockout will occur if a bad tube is detected during safe start check. If a tube fails during normal operating flame-on conditions, the bad tube may not be recognized until a system re-start, when a safe start check is initiated. It is for this reason that scanner self-check systems were developed. A self-check system for an UV, tube type flame detector consists of an optical shutter device placed directly in the path of the tube's UV radiation.

The shutter opens and closes continuously, effectively blocking the UV radiation for a brief period (0.25 to 0.75 sec. depending on design, but less than the FFRT). The FSG system drives the scanner self-check shutter mechanism and checks for the scanner's pulse count to stop during the shutter-closed period. Scanner pulse counts detected during the shutter closed time causes the system to react to scanner self-check failure; by shutting off fuel and going to lockout. When using UV tube-type flame detectors, a scanner with self-check feature is mandatory for burners or appliances that are designed for continuous operation.



**Fig. 12** UV tube detector, AC current operation principle.

Continuous operation is defined as 24 hours of continuous use. In addition, UV self-checking scanners are mandatory in some locations, regardless of continuous operation. Ultra violet accounts only for about one percent of available radiation in the flame spectrum. UV also is relatively weak and is easily blocked by unburned fuel, products of combustion, smoke, water vapor, and other common substances found in and around flames. Accordingly, a detector close to the root of the flame picks up UV most easily, and UV radiation from background or adjacent flames tends to be a much weaker signal. With proper scanner sighting and set-up of associated controls, UV flame scanners remain a simple, well-trusted and acceptable option in today's FSG systems.



**Fig. 13** UV self check scanner.  
Fireye part no. 45UV5

### INSTALLATION; UV SCANNERS

Where possible, obtain the burner manufacturer's instructions for mounting the scanner. This information is available for most standard burners. The scanner mounting should comply with the following general instructions:

1. Reliable pilot signal
2. Reliable main flame signal.
3. A pilot too small or in the wrong position to ignite the main flame reliably, must not be detected.
4. The scanner must have an unobstructed view of flame being monitored.
5. Monitored flame must completely cover the scanner's field of view.
6. Position the scanner within the closest distance from the flame to be monitored (within 72 inches is recommended).
7. Select a location that will remain within the ambient temperature limits of the scanner. For UV scanners model 45UV5 this is max. 140 F (60 C) and for model UV1A maximum temperature is 200 F (94 C). Minimum temp is -40 F/C.
8. If cooling is required, you can use an insulating coupling, Fireye # 35-69 for UV1A scanners and Fireye # 35-127-1 for 45UV5 scanners, to reduce conducted heat. Cooling air can be added to reduce sight-pipe temperatures.
9. UV1A and 45UV5 scanners are not designed to seal off any sight-pipe pressures. To seal off positive furnace pressures in excess of 12 " WC, use Fireye # 60-1257, 1/2" NPT quartz window

arrangement for UV1A scanners. For 45UV5 scanners use Fireye # 60-1199, 1" NPT quartz window arrangement.

10. When possible, install the scanner on a standard NPT pipe (1/2" NPT for UV1A and 1" NPT for 45UV5) whose position is rigidly fixed. If the sight-pipe sights through refractory, do not extend it more than halfway through. Swivel type mounts are available if desired: Fireye # 60-302 for UV1A and Fireye # 60-1664-3 for 45UV5 scanners.
11. The sight-pipe must permit an unobstructed view of the pilot and/or main flame. Both pilot and main flame must completely cover the scanners' field of view.
12. Smoke or unburned combustion gases absorb UV energy. On installations with negative pressure combustion chambers, a small hole drilled in the sight-pipe may assist in keeping the pipe free from smoke. For positive pressure furnaces, provide clean purge-air to pressurize the sight-pipe if necessary.
13. A quartz lens can be used to increase scanner sensitivity, or to allow location of the scanner at twice the normal recommended distance.

### WIRING, UV SCANNERS

Fireye UV1A scanners are supplied with 36" or 72" long flexible armored cable. The two leads connect to S1 and S2 terminals located in the control's wiring base. Fireye 45UV5 scanners are supplied with four lead wires, each 72" long. These are to be installed in a suitable length of flexible armored cable. A conduit connector is supplied with this scanner. Connect the two red leads (signal) to terminals S1 and S2 and the two black leads (shutter) to terminals L1 and L2 located in the control's wiring base.

If necessary to extend the scanner wiring, the following instructions apply:

1. For extended wiring up to 500 feet; for each individual scanner wire of an UV1A, and each red wire of an 45UV5 scanner use shielded wire (Belden 8254-RG62 coaxial cable, or equal). The ends of the shielding must be taped and not grounded.
2. Avoid the use of asbestos wire.
3. Multiconductor cable is not recommended.
4. Keep any high voltage or ignition wiring away from all scanner wiring.

## INFRARED FLAME DETECTION

Flame scanners operating in the visible and infrared spectrum utilize a lens, photo-detector and a solid-state frequency tuning circuit.

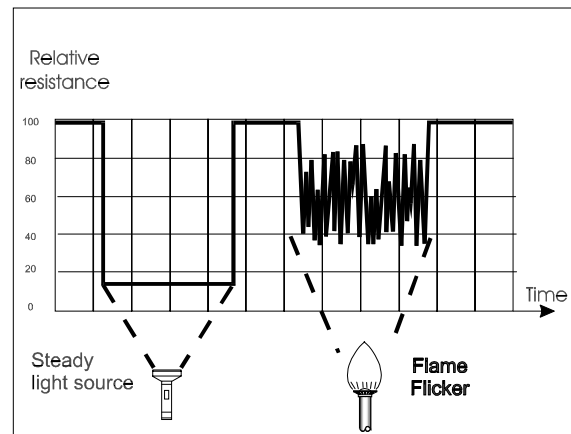


**Fig. 14** Infrared scanner with heat insulating mounting nipple. Fireye part no's. 48PT2 and 35-69.

In itself, IR and visible light, (400 nanometers wavelength and upwards) is not overly useful in detecting presence or absence of flame. A furnace area of a boiler with hot, glowing refractory contains both visible and IR radiation in great abundance and simply detecting the presence or absence of it, would not give any certainty of the on, or off condition of the targeted flame. In order to identify the targeted flame an IR scanner monitors the modulating frequency (flicker) of the radiation it receives. IR is radiated from a flame in a multitude of frequencies, called Flame Flicker. The burning process consists of a large number of small explosions as molecules of fuel unites and ignites with oxygen. Each of these explosions emits light and other radiation, giving the flame an appearance of relative steady shape and glow. When a high-speed film of a flame is played back, it reveals that the flame is constantly on the move changing shape and changing in brightness. It is the photo-detector's ability to monitor flame flicker, through the ability to alter its resistance in harmony, which makes the flame detector useable to distinguish between flame and other sources of radiation. The photo-detector most commonly used is the PbS (lead sulfide) photo resistor. The PbS cell lowers its electrical resistance in relation to amplitude of radiation >400 NM. (visible infra-red) region on the cell. The cell responds in a

modulating fashion, harmonized with the variations in radiation amplitudes given off by the combustion process. Not only do flames flicker in this way, the flicker frequency is actually different within the zones of the flame. If we look back at figure 8 for a moment, it would be the ultra-violet region of the flame, nearest the nozzle, the ignition-zone, which has the least amplitude but the highest flame flicker frequency. The opposite end, farthest from the burner nozzle produces the most amplitude of radiation but of the lowest flicker frequency. Thus a flame scanner mounted on the burner-front looking parallel with fuel flow would have the best possible view to pick up as much as possible of the ignition zone of its targeted flame. Should its targeted flame disappear, it would likely pick up radiation of lower frequency from hot surfaces such as refractory. If the detector's circuitry is designed in a way that it can be selective in the frequency it accepts as flame signal, then discrimination between targeted flame and background can be achieved.

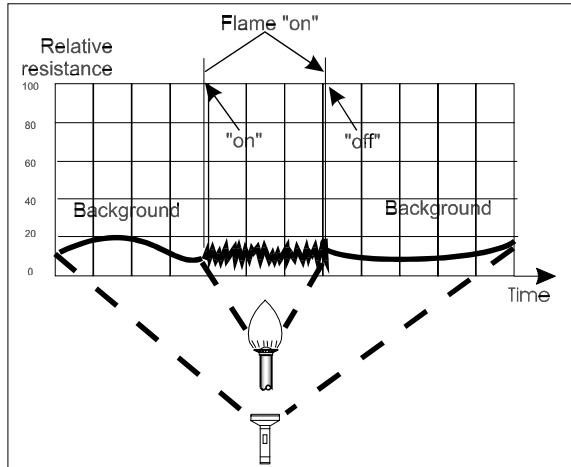
Flame flicker frequency is noted in Hertz. Flicker frequencies in flames can be found from 5 upward to well over 200 Hz. Variations in higher or lower frequencies found in flames are related to a variety of functions in burner design and fuel burned. Burner designs such as gun-type or ring-type produce flames with a wide range of frequencies, where as spud-type (gas) and low-NOx burners do not.



**Fig. 15** IR cell response to IR (DC) radiation and flame flicker.

Fuel oils and coal produce wide ranges of frequencies, where as fuel-gas, particularly low NOx or sub-Stoichiometric combustion does not.

This ability of the flame scanner to pick up flame flicker frequency can be adversely affected by over-powering low frequency radiation from furnace background.



**Fig. 16** IR cell saturation effect from abundant, low frequency infrared radiation.

Strong sources of this low frequency radiation will have a saturation effect. Also called Washout, saturation inhibits the cell's ability to maintain a high enough electrical resistance value, rendering it unable to monitor flame flicker. Imagine that in figure 16 the symbolic flashlight represents the low frequency IR-visible light radiation from furnace background and that the symbolic flame represents the ignition zone of the targeted flame. We see that the furnace background radiation focused on our detector drastically reduces its electrical resistance, leaving almost no room for the cell to respond to flame flicker modulation. To minimize this saturation effect it is desirable to sight the detector such that radiation from the ignition zone is maximized while radiation from furnace background is minimized. A task not always made possible within burner design. A later chapter dedicated to scanner sighting and positioning, deals with this issue in more detail. Lets look at frequencies of flame flicker as related to fuel being fired. Back in figure 9 we observed that oil and coal flames have strong radiation in the visible wavelength, and gas flames do not. Anyone having seen oil and coal flames through a burner's sight-glass will confirm the relative brightness of these fuels while burning, whereas gas flames tend to be more transparent or dim. All fuels however, radiate profusely in the infra red region of the flame

spectrum. Where the detector is sighted at the ignition zone of the targeted flame, it is not uncommon to find that the lowest frequencies increase dramatically in a "flame off" condition. This is due to the ignition zone of the targeted flame "masking" the bright background low frequency radiation while the targeted flame is on. Upon disappearance of the targeted flame this background radiation comes into full view.

## INSTALLATION OF INFRARED SCANNER

Where possible, obtain the burner manufacturer's instructions for mounting the scanner. If a single scanner is used to detect both pilot and main flames, the sight pipe must be aimed so that the scanner sights a point at the intersection of pilot and main flame. Proper scanner positioning must assure the following:

- 1) Reliable pilot signal.
- 2) Reliable main flame signal.
- 3) A pilot too small or in the wrong position to ignite the main flame reliably, must not be detected.
- 4) The scanner must have an unobstructed view of flame being monitored.
- 5) Monitored flame must completely cover the scanner's field of view.
- 6) Avoid sighting hot refractory.
- 7) Maintain scanner temperature as cool as possible (below 125 F (50 C))
- 8) Use 6" to 8" length of pipe between scanner and hot furnace plate.
- 9) Use Fireye P/N 35-69, heat insulator on the end of sight-pipe.
- 10) Sight-pipe should not extend more than half way through refractory wall.

## WIRING FIREYE IR SCANNER P/N 48PT2

Attach the cable supplied with scanner to a junction box. Splice the cable wires to a pair of wires not smaller than #18 gauge wire. Install the complete run in separate conduit to the control. Do not pass scanner wiring through any junction box containing other wires. Do not run other wires through scanner conduit. Continuous conduit bonding between scanner and control is important. The scanner may be located up to 100 feet (30 M) from control.





## TROUBLE SHOOTING AND TESTING OF FLAME DETECTORS.

Any flame detector system must be thoroughly inspected and tested prior to putting the system into permanent service. The following is a suggested listing of tests used to assure a safe system of flame detection:

1. Flame signal measurement (required for all types of flame detectors).
2. Hot refractory saturation test (required for infrared flame detectors).
3. Hot refractory hold-in test (required for visible light and infrared flame detectors).
4. Ignition spark sensing test (required for ultraviolet flame detectors).
5. Ignition interference test (required for flame rod type detectors).
6. Pilot turndown test (required for all flame detector types, when used to detect pilot flame).



**Fig. 17** Infrared scanner P/N: 48PT2 contains; Cell P/N: 4-263-1 and Lens P/N: 61-436

### FLAME SIGNAL MEASUREMENT

A steady flame signal of at least recommended minimum strength must be maintained throughout the operation of the burner. The minimum acceptable signal strength is listed in the technical bulletin of the control used. The flame signal can be checked via “test-jacks” provided (located on flame amplifier module), or via its control display readout. Unstable readouts may be caused by:

1. Unstable flame conditions.
2. Incorrect supply voltage.
3. Defective detector wiring.
4. Electrical noise on detector wiring.
5. Dirty viewing lens.

6. Faulty detector rod (flame rod), cell (infrared) or tube (UV).
7. Excessive detector temperatures.
8. Detector location.

### HOT REFRACTORY SATURATION TEST

Performed to insure that hot refractory does not blind or saturate the detector, preventing it from sighting radiation from the targeted flame.

- a) Start burner.
- b) Monitor flame while heating refractory.
- c) Note if any decline in flame signal as refractory heats.
- d) If signal declines, detector likely sights refractory. Try re-sighting scanner to see little or no refractory. If not possible try placing an orifice in front of scanner lens to reduce field of vision. Alternately, changing to a UV scanner may resolve this problem.

### HOT REFRACTORY HOLD-IN TEST

This test is done for infrared detectors to determine whether there is enough hot refractory sighted, combined with “shimmer” inside the combustion chamber, which could duplicate false flame signal.

- a) Start burner.
- b) Monitor flame while heating refractory.
- c) With refractory at maximum temperature, close manual fuel valve(s).
- d) With flame now out, take note of the time it takes for the FSG control to drop out its flame relay (close electric fuel valves).
- e) If d) is not within the flame failure response time (FFRT) of the FSG control, the system is experiencing hot refractory hold-in. Corrective measures must be taken. Try re-sighting scanner to see little or no refractory. If not possible try placing an orifice in front of scanner lens to reduce field of vision. Alternately, changing to an adjustable frequency range type infrared scanner, or to a UV scanner may resolve this problem.

### IGNITION SPARK SENSING TEST

This test is required on UV type detectors, proving that the detector is not picking up UV radiation from the ignition spark, creating a false flame sensing condition.

- a) Shut off pilot and main manual fuel valves.
- b) Start burner.



- c) Monitor for any flame signal during ignition spark period.
- d) There should be no signal what so ever.
- e) If any signal, take corrective action: Either re-sight the detector, or shield the detector from the spark via a metal shield at ignition electrode.

### IGNITION INTERFERENCE TEST

The ignition interference test is done on any flame rod system. It serves to determine whether or not ignition interference is creating a false flame signal from electrical noise, created by the ignition and superimposed on the flame rod system. Note that this can be either additive or subtractive to the flame signal.

- a) Start normal burner cycle.
- b) Monitor flame signal during, and after spark ignition.
- c) If a noticeable difference is observed, ignition interference is experienced and the following may help to alleviate
  - a)  Check for proper grounding area.
  - b)  Maintain maximum distance between ignition electrode and flame rod.
  - c)  Check ignition electrode(s) spacing (1/16" to 3/32")
  - d)  Replace deteriorated ignition / flame rod leads.

### PILOT TURN-DOWN TEST

Required on any type of flame detection system, this test should be performed on:

- a) Any new installation.
- b) Following any changes to the detector's location or viewing angle.
- c) Following replacement of the flame detector.

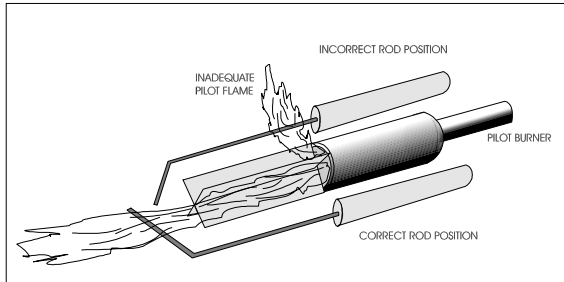
This test serves to assure that the detector is positioned such that it will not detect a pilot, which is insufficient to reliably light off its main burner. The minimum pilot is the smallest possible pilot flame that a flame detector will sight to hold in the flame relay on its FSG control:

- a) Shut manual fuel valve to main burner (test firing valve).
- b) Start burner.
- c) Monitor flame signal during pilot trial for ignition (PTFI). (Some systems; Fireye Flame Monitor and Fireye MP560, have a "run-check" switch to stop and hold program during PTFI for this purpose)

- d) Reduce fuel supply to the pilot burner until flame signal is at its minimum (see technical bulletin of FSG control for this information). This is the minimum pilot detectable.
- e) Light off main fuel and insure that the main flame lights off promptly and smoothly (within 1 second).
- f) If light off appears to be delayed, re-sight detector so that a larger minimum pilot flame is required.
- g) Repeat test until main lights smoothly with minimum pilot.
- h) After completion of test, restore pilot flame to its normal capacity.

**TIPS FOR FLAME DETECTOR MOUNTING AND ENCLOSURES.**

**Flame rod** applications allow for pin-point accuracy in location of a pilot flame. Particular attention should be given to the ability of the pilot flame to light off the main flame reliably and under all conditions.

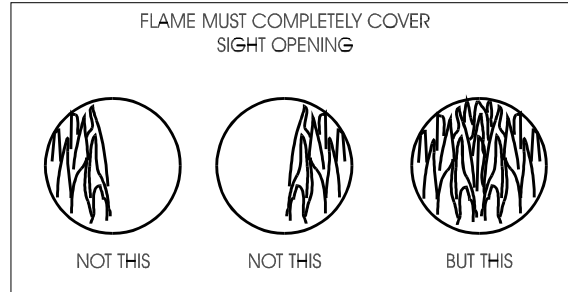


**Fig. 18** Importance of flame rod placement.

As is shown in Fig. 18, it is important that the flame rod enters the pilot flame from the side so as to safely prove an adequate pilot flame under all draft conditions.

Note the rectangular plates attached to the pilot burner assembly to provide a large grounding surface. Proven types of flame grounding adapters as shown may be used to provide adequate grounding. High temperature stainless steel should be used to minimize the effect of metal oxidation and these assemblies may be welded directly to the pilot burner nozzle.

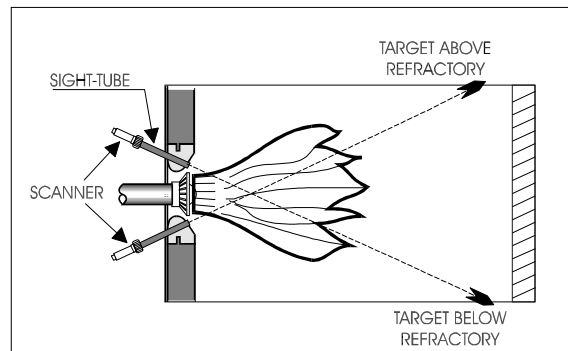
When the pilot burner assembly includes a spark igniter, care should be given to place it opposite the flame rod. Also, interference from the ignition spark can alter the true signal by adding to, or subtracting from it. Interchanging the primary wires (line voltage) to the ignition transformer sometimes may reverse this trend. The addition of grounded shielding between flame rod and ignition spark may also reduce this interference.



**Fig. 19** Scanner sight-tube must provide unobstructed view of flame.

**Optical flame detectors** need to be mounted on a sight-tube. Care should be given that the sight-tube permits an unobstructed view of the pilot and/or main flame. Both pilot and main flame must completely cover the scanner's field of view.

Preference should be given to an angular (about 5 to 25 degrees) on-axis view, perpendicular with the fuel nozzle.

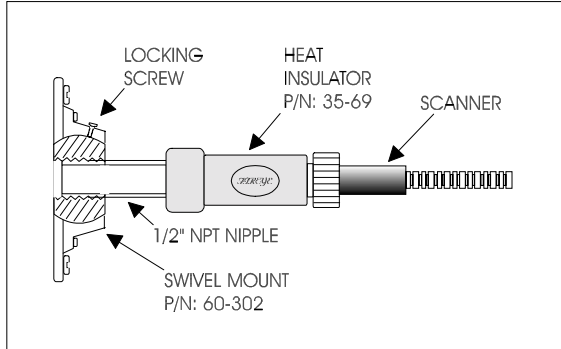


**Fig. 20** Scanner sighting

**Infrared scanners** must not sight hot refractory as this may cause unwanted signal or detector saturation. If at all possible aim infrared scanners away from refractory as shown in Fig. 20. Alternately, extending the length of the sight-tube, or place scanner orifices inside the sight-tube arrangement in order to minimize refractory sighting. In any event, a "hot refractory hold-in test" should be performed.

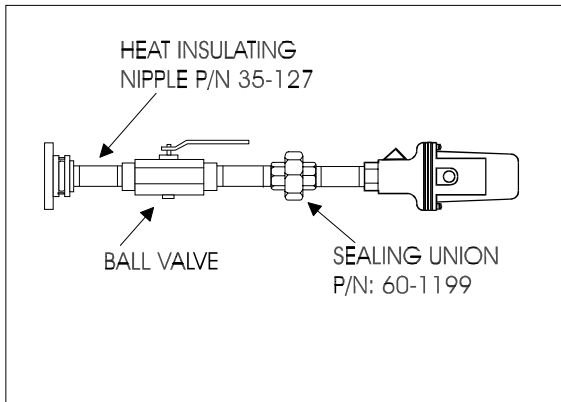
**Ultra Violet** scanners should be aimed at the first one-third of the flame. This is the area where the maximum UV signal from a flame is found.

**Swivel mounts** are used to simplify scanner sighting. They are available for 1/2" and 1" NPT scanner mountings and are bolted to the burner front. The scanner sight-tube is threaded into the swivel mount, with the scanner mounted at the other end. When satisfactory aiming is achieved, the swivel mount's locking bolts are tightened.



**Fig. 21** 48PT2 or UV1A scanner mounting using swivel mount and heat insulating nipple.

**Sealing unions** are provided with either a Pyrex (for infrared) or quartz (for UV) window and are used to protect the scanner against excessive furnace pressures. It is good practice to install these along with a ball valve for servicing.



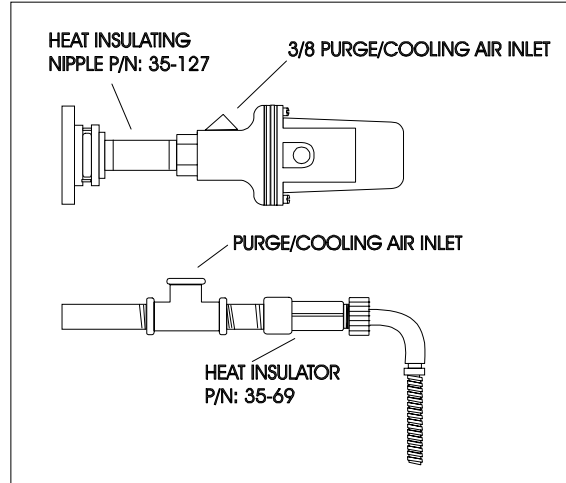
**Fig. 22** UV self check scanner installed in high furnace pressure application.

**Purging air** is used to prevent the sight tube from becoming obstructed by dust or dirt and also serves to keep the scanner cool.

For large multi burner furnace installations scanner cooling air fan assemblies may be used. These fans provide ambient air at a few inches of water column above furnace pressure and this air is distributed to all scanners via cooling air piping. On smaller installations instrument-air is often used. Scanners need very

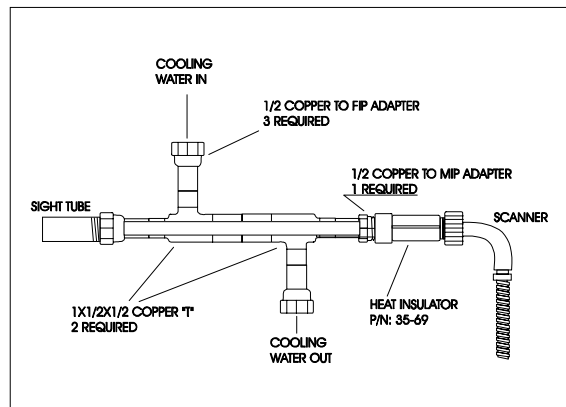
little of this purge/cooling air; 4 SCFM or 113L/min is recommended.

Fireye self check scanners are provided with a 3/8 " NPT purge air opening. Infrared, 48PT2 and UV, UV1A scanners need to have fittings installed on the sight tube arrangement to suit.



**Fig. 23** Purge/cooling air details.

In extremely high temperature applications it may be required to cool the sight tube with cooling water. Figure 24 shows how, by using an assortment of standard copper fittings, a water-cooled sight tube may be made.

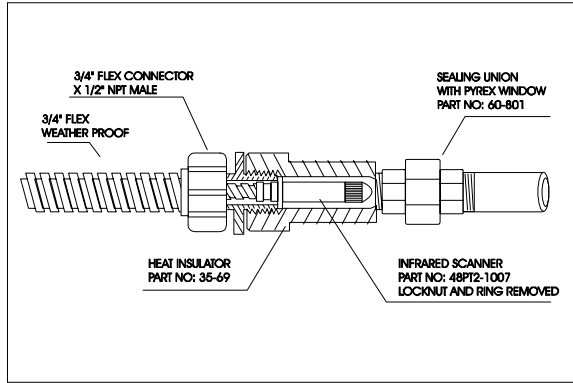


**Fig. 24** Water-cooled sight tube for 1/2 inch mount scanners.

The copper tees need the end-stops located inside the female 1/2 inch connections removed in order to allow a 1/2 inch copper tube to run uninterrupted from the sight tube end to scanner end. This arrangement can easily be adjusted to be used with 1 inch mount scanners also.



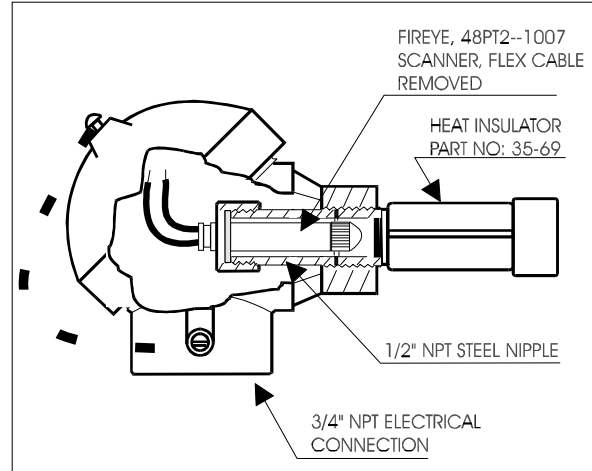
**Enclosures** for Fireeye standard scanner types 45UV5, UV1A and 48PT2 do not have listed NEMA ratings. By design, these scanners are suitable for use both indoor and outdoor application and their enclosures provide protection against wind-blown dust and weather hazards such as rain, sleet or snow.



**Fig. 25** Weather proofing a 48PT2 scanner.

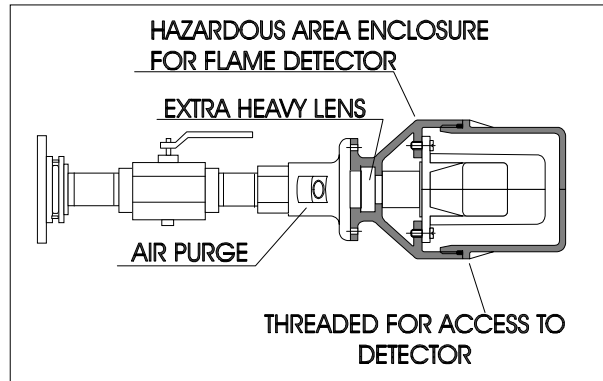
For applications with a 48PT2 infrared scanner, where that extra bit of protection is required, you may consider the assembly described in figure 25. Here the heat insulator P/N: 35-69 (supplied with all 48PT2 scanners) is used backwards. The scanner has its lock-nut and ring removed and is inserted into the female threaded end of the 35-69. It will seat on the ridge where the female threads end, and threading in a weatherproof flexible conduit connector completes the assembly. Finally, insert the male threaded portion of the 35-69 into the sealing union P/N: 60-801 and mount it on the sight-tube.

To meet specified NEMA ratings, the detector needs to be housed in an enclosure which is certified to the desired rating. For the relative small UV1A and 48PT2 scanners, various types of enclosures are available ranging from junction boxes to instrument enclosures. Industrial type thermocouple heads are readily available in NEMA ratings varying from the lowest to the highest. See figure 26.



**Fig. 26** Enclosure rated for Class 1 & 2, DIV. 1, Groups B, C, D, E, F, & G, and NEMA 4, for UV1A or 48PT2 scanner. For NEMA 4X, this housing must be epoxy coated.

For the larger, self check type 45UV5 scanners when used in areas requiring hazardous area classification, these can be ordered with special enclosures. Figure 27 shows the European style, CENELEC approved housing rated at IP-66. This enclosure is also available for scanners using fiber optics.



**Fig. 27** Cut-away view of flame detector mounted in Cenelec approved hazardous area enclosure rated IP-66 (NEMA 4X).



## COMMON TERMS IN FLAME SAFEGUARD

Flame failure response time (FFRT) is the time from loss of flame, to the closure of fuel valve(s). This may vary from 4 seconds (maximum) to less than 1 second. The control may respond by recycling or re-lighting the burner, or by going into a safety lockout requiring manual reset.

**Prepurge** is required to provide a complete air change to the combustion chamber. A prepurge time is a period of time after the combustion air fan has been started and proven, (sometimes the combustion air damper is driven and proven to the high purge position) during which the combustion chamber and flue gas passages are provided with minimum of four complete air changes.

**Pilot Trial For Ignition** time (PTFI) is the maximum time allotted for the system to establish and detect the pilot flame during start up. Failure to establish the pilot flame within the selected PTFI will cause the flame safeguard system to lockout on safety, requiring a manual reset.

**Main Trial For Ignition** time (MTFI) is the maximum time during which both the pilot and main fuel safety valve(s) are permitted to be open before the pilot valve is de-energized and the flame safeguard system is to supervise the main flame alone.

**Post Purge** time is a short period of time (10 – 15 sec.) after the a burner cycle during which the combustion air fan continues to operate, evacuating products of combustion from the furnace area.

## TYPES OF PILOT BURNERS

**Interrupted Pilot:** is a pilot that is ignited during each burner cycle and withdrawn after establishing main flame, at the end of MTFI.

**Intermittent Pilot:** is a pilot that is ignited with each cycle and remains on throughout the entire running cycle and is terminated the same time as the main flame at the completion of each cycle. In order to have an MTFI period, the burner must utilize an interrupted pilot, unless two separate flame detectors are used; one for pilot and one for main.

**Standing Pilot,** or continuous pilot, is a pilot that burns regardless of whether the burner is firing or not. Generally these pilots are used in atmospheric burner systems and most often need to be manually lit. In any event, a standing pilot must be monitored by a flame detection system.

## FLAME SAFEGUARD CONTROLS

A flame Safeguard system consists of a flame safeguard control, also called flame relay, and a flame detector. The primary functions of a flame safeguard control is to:

1. Properly sequence the burner's operation through its start up, running cycle and its shutdown.
2. Provide flame supervision, de-energizing the fuel supply valves within the flame failure response time if flame is no longer detected.
3. Monitor the safety interlocks before and during the operation of the burner.
4. Provide "safe start check", during which the control prevents a burner start up if flame signal is present prior to its next cycle.

## OPERATING INTERLOCK CIRCUIT

The operating interlock circuit, when closed, cycles the burner on and off. Burner cycling, or operation, i.e. call for heat, or call for steam, is provided by the Controller. The controller is the device which cycles the burner, for example: An aquastat for hot water systems, an area thermostat for commercial heating systems, or a pressure sensor for steam boilers. The controller is wired into the operating interlock circuit. Other devices such as a low water cut-off, or remote setpoint control, are sometimes also wired into the operating interlock circuit, preventing the burner from operating unless the device allows it, and recycling the burner when the condition is met.

## RUNNING INTERLOCK CIRCUIT

The running interlock circuit, when closed, insures the operating limits of all safety devices wired into it are met. The term "running interlock circuit" refers to the fact that some of the safety devices being checked are not into play until the flame safeguard control has started its cycle. For example, the combustion air fan is first turned on by the control and then its proper operation is verified via an "air-proving device".



Some examples of running interlocks:

- High temperature or pressure limits.
- High and low fuel pressure limits.
- High and low water cutoff
- Proof of closure switch on fuel valve(s).
- Combustion airflow limit.

The above mentioned operating and running interlock circuits, along with the flame detector circuitry, are inputs to the system. A flame safeguard system also needs to control and operate various equipment found on a burner via its' outputs. For example:

- Combustion-Air fan
- Ignition transformer.
- Pilot fuel valve.
- Main fuel valve.
- Modulation motor.

Flame safeguard controls can be classified in three main groups:

1. Non programming controls
2. Programming controls
3. Flame switches

**FIREYE, M SERIES FLAME SAFEGUARD CONTROLS**

A Fireeye M series type flame safeguard control provides the minimum basic functions to safely operate a burner. It monitors the inputs from the operating control, interlocks limits and flame detector and translates these into control outputs to the combustion air-fan motor, ignition transformer, pilot fuel valve and main fuel valve. Fireeye M series controls are used for supervision of small and moderate size burners, firing gas and light fuel oil.



**Fig. 28** M Series, model TFM1 control.

**UVM / TFM CONTROLS**

Fireeye UVM and TFM controls (discontinued in 1999 and replaced by the Fireeye M Series II control) provide five basic styles of function:

1. M1: Relight
2. M2: Recycle with prepurge
3. M3: Non recycle with prepurge
4. M3H: Non recycle with prepurge and pilot stabilization period.
5. M5: Non recycle with prepurge, pilot stabilization period and interrupted pilot.

The UVM and TFM controls monitor both pilot and main flames and with pilot ignited burners prevent the main fuel valve from being energized until the pilot flame is proved. With spark ignited burners the trial for ignition is safely limited to 10 seconds, with 4 seconds available in models M2, M3, M3H and M5.

Plug in purge timer cards for use with M2, M3, M3H and M5 provide selectable 7 or 30 or 60 or 90 second prepurge. A running interlock circuit is provided for an airflow switch and other limits and is monitored throughout the operating cycle. In the event of PTFI failure, or following a safety shutdown, the lockout switch trips, activating an alarm circuit.

UVM and TFM controls incorporate a safe start check circuit that is operative on each start. If flame, real or simulated, is detected prior to a start or during prepurge, the unit will perform a safety shutdown.

Below are the M Series models:

- UVM1D: UV, FFRT: 0.8 sec., Relight
- UVM1F: UV, FFRT: 4.0 sec., Relight
- UVM2: UV, FFRT: 4.0 sec., Recycle
- UVM3: UV, FFRT: 4.0 sec., Non Recycle
- UVM3H: UV, FFRT: 4.0 sec., Non Recycle
- TFM1D: FL. Rod, FFRT: 0.8 sec., Relight
- TFM1F: FL. Rod, FFRT: 4.0 sec., Relight
- TFM2: FL. Rod, FFRT: 4.0 sec., Recycle
- TFM3: FL. Rod, FFRT: 4.0 sec., Non Recycle
- TFM3H: FL. Rod, FFRT: 4.0 sec., Non Recycle

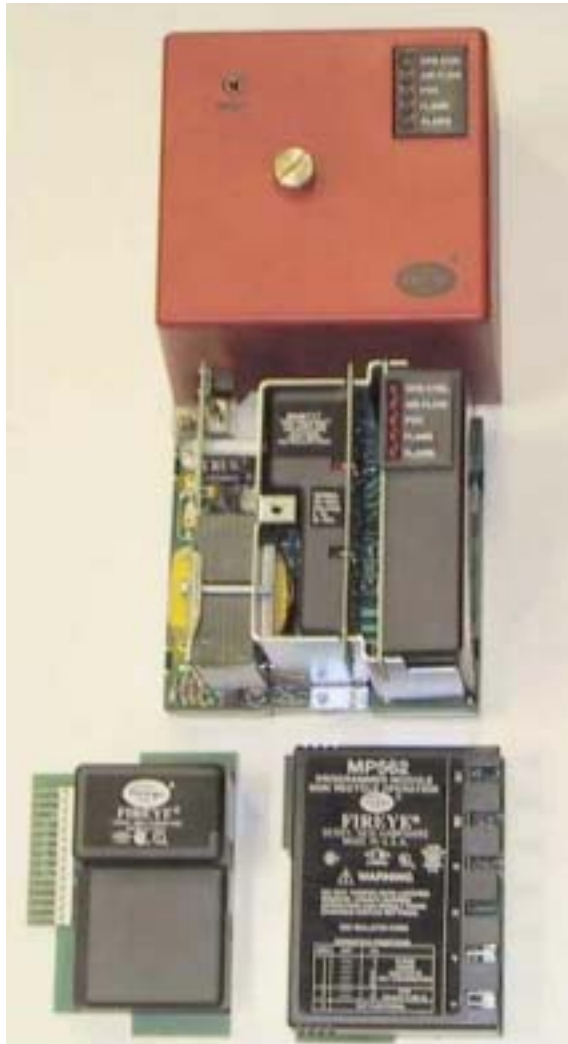
Purge timing Cards for M2, M3 or M5

Card	Prepurge	PTFI
MT55	5 sec.	5 sec.
MT74	7 sec.	4 sec.
MT304	30 sec.	4 sec.
MT710	7 sec.	10 sec.
MT904	90 sec.	4 sec.
MT3010	30 sec.	10 sec.
MT6010	60 sec.	10 sec.
MT9010	90 sec.	10 sec.



## FIREYE, M SERIES II

**Fireye, Modular M Series II** controls are of solid state design and provide a multitude in basic styles of functions. The M Series II is a compact, modular design flame safeguard control, designed to provide automatic ignition and flame monitoring for commercial heating and process burners. Interchangeable programmer and flame amplifier modules allow for versatility in selection of control functions, timing, and flame detector types. The programmer module determines control functions. Detector type and flame failure response time (FFRT) are determined by the amplifier module.



**Fig. 29** M Series II: Control with cover, chassis with modules, amplifier and programmer module.

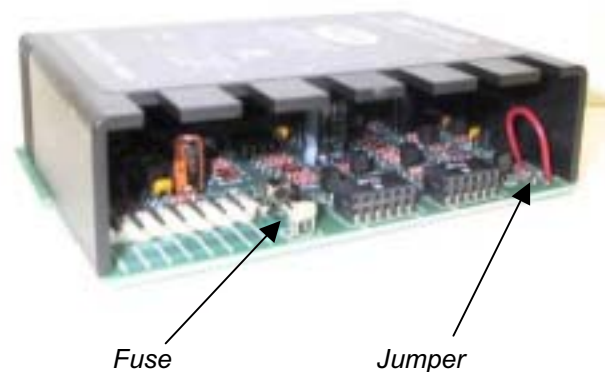
Programmer modules may be equipped with dipswitches to select Purge timing, Pilot Trial for Ignition (PTFI) timing, and Recycle or Non-Recycle operation. The M Series II has a clear plastic window covering all dipswitches, which must be in the closed and permanently locked position in order for the programmer to be operational. Programmer modules are also provided with LED indicator lights characterizing the operating status of the control.

The following components are required for a complete system.

1. Control Chassis
2. Amplifier Module
3. Programmer Module
4. Wiring Base
5. Flame detector

The **Control Chassis** for the Modular M Series II control are designed to receive the flame amplifier and programmer module, which insert into their respective slot. The following models are available when selecting the chassis:

- MC120 120vac, 50/60 Hz.
- MC120R 120vac, 50/60 Hz. Remote reset
- MC120P 120vac, 50/60 Hz. Post purge
- MC230 230vac, 50/60 Hz.
- MC230R 230vac, 50/60 Hz. Remote reset



**Fig. 30** Programmer module. Showing location of jumper and replaceable fuse. Fuse protects control outputs. Jumper is on 100 series programmers only and is clipped when used on "standing pilot burners" with flame rod detection.





**Programmer Modules** are the heart of the system and are selected based on functions required. The following models are available:

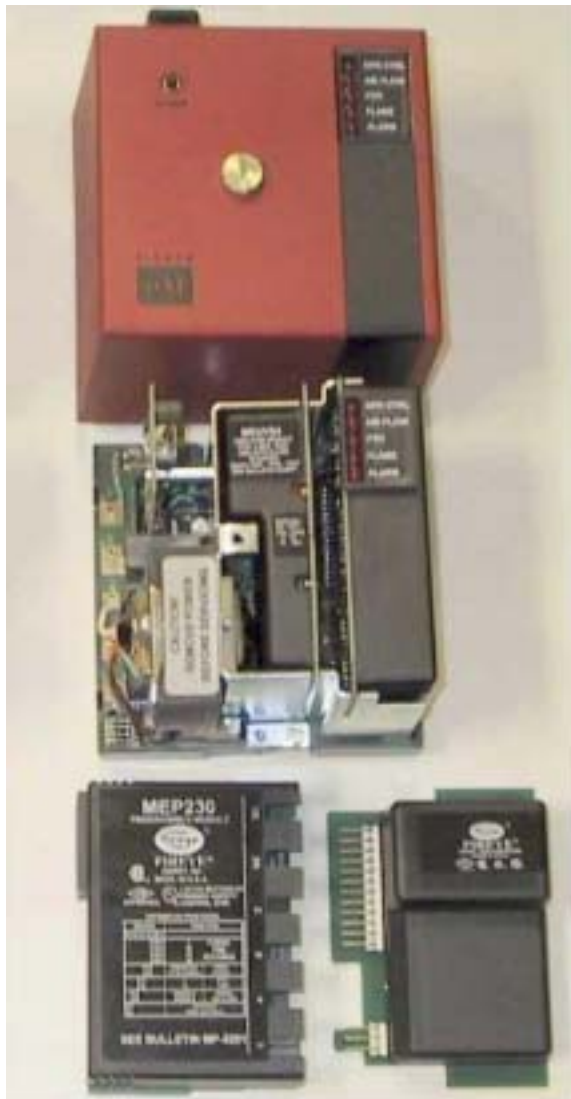
- MP100 Relight operation. Control will relight on flame failure during main flame on. Locks out if pilot fails to be detected.
- MP102 Non-relight. 5 sec. PTFI
- MP230 Selectable prepurge and PTFI timing, recycle/non recycle operation.
- MP230H Same as MP230, with pilot stabilization period.
- MP560 Same as MP230H, with 10 sec. MTFI. Includes run-check switch.
- MP561 Same as MP560, with lockout on flame fail and running interlock.

**Amplifier Modules** are selected based on type of flame detector and required FFRT. The following flame amplifier modules are available:

- MAUV1 UV Detector, 2-4 sec. FFRT.
- MAUV1T UV Detector, 0.8 sec. FFRT.
- MART1 Flame Rod Detector, 2-4 sec. FFRT.
- MART1T Flame Rod, Detector, 0.8 sec. FFRT.

## FIREYE, MICRO M SERIES

Fireye, Micro M Series controls are of microprocessor based design and, as with the M Series II, are a modular burner management system designed to provide automatic ignition and continuous flame monitoring for commercial sizes of heating and process equipment firing any type of fuel. The Micro M design is backward compatible to the wiring base of existing UVM, TFM and M Series II controls. The Micro M incorporates smart diagnostic LED's causing the programmer's LED's to illuminate in a coded sequence identifying the reason for the lockout.



**Fig. 31** Micro M series: Control with cover, chassis with modules, programmer and amplifier module.

This remains true even if power was removed and later restored during a lockout condition. Lockout codes are described in detail in the Micro M technical bulletin MC-5000.

There is also provision for "Smart Reset", in where the control's remote reset terminals of multiple units can be wired parallel to a common push button. Useful in a multi burner system where the controls are mounted in a common panel. The Smart Reset function allows, when the remote reset push button is energized for between 3 and 5 seconds, to reset only those controls which are in lockout condition, without affecting those which are in normal operation.

The Micro M control is also compatible with the Fireye alpha numeric display module, part no. ED510, which can be remote-mounted for permanent use via a remote mount kit part no. 129-145, or can be used hand-held as a service tool to retrieve important service related information.

Serial communications are available via either a Modbus driver, or a Fireye E500 communications interface.

The Micro M series control provides for greater flexibility in flame detector selection. In addition to the standard UV1A non self-check UV, and Flame Rod applications, this control is also compatible with 45UV5-1009 self-check UV scanners, 48PT2 Infra Red scanners, and Cadmium Sulfide detectors.

Amplifier modules are selected based on type of flame detector and required flame failure response time (FFRT).

Programmer modules are equipped with smart LED's and may be equipped with dipswitches to select Purge timing. Pilot Trial for Ignition (PTFI) timing, and Recycle or Non Recycle operation.

A "Burn-in Time", at which the dipswitch setting become permanently stored, occurs after 8 hours of continuous operation of the control.

The following components are required for a complete system:

1. Control Chassis
2. Amplifier Module
3. Programmer Module
4. Wiring Base
5. Flame Detector

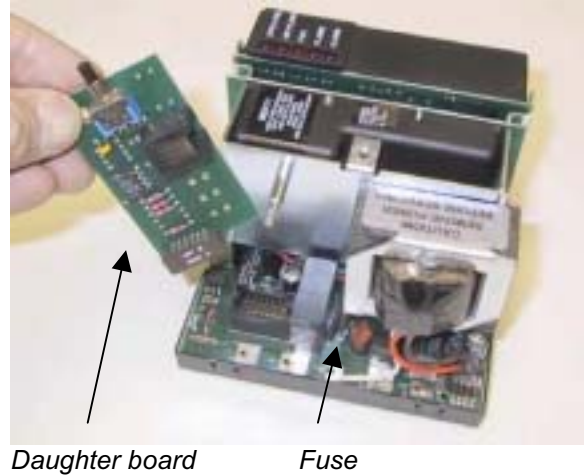


**The control Chassis** for the Micro M series control is designed to receive the flame amplifier and programmer module, which insert into its respective slot. When selecting a control chassis, the following modules are available:

- MEC120 120vac, 50/60 Hz.
- MEC120R 120vac, 50/60 Hz. Remote Reset
- MEC120D 120vac, 50/60 Hz. Display Output
- MEC120C 120vac, 50/60 Hz. Communications
- MEC120RC 120vac, 50/60 Hz. With R and C
- MEC230 230vac, 50/60 Hz. With R, D and C

**Programmer Modules** are the heart of the system and are selected based on functions required. The following models are available:

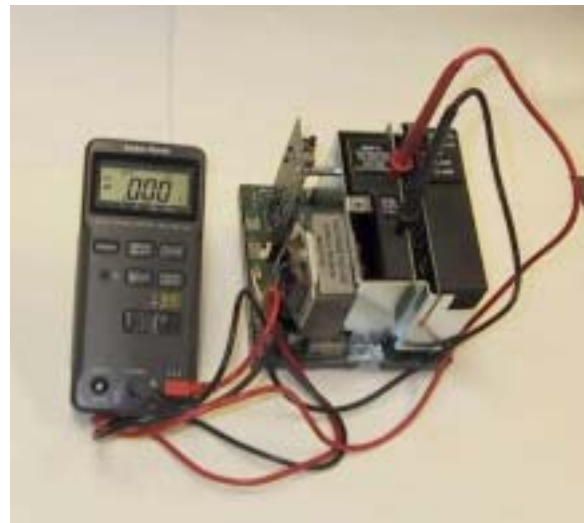
- MEP100 Relight operation, 10 sec. PTFI
- MEP101 Same as MEP100 but allows flame signal during “off cycle”
- MEP102 Same as MEP100 with 10 sec. PTFI
- MEP103 Fixed 10 sec. PTFI, 10 sec. MTFI and Post purge. Will retry once on pilot failure.
- MEP104 Non recycle on flame fail, 10 sec. PTFI
- MEP105 Non recycle on flame fail, lockout on limit failure, 10 sec. PTFI
- MEP100P Same as MEP100 with 15 sec. Post purge.
- MEP230 Selectable: PTFI, Pre-purge timing, Recycle or Non Recycle, Prove limits open on start.
- MEP230H Same as MEP230 with 8 sec. Pilot stabilization period.
- MEP234 Selectable: PTFI, Pre-purge timing, Prove limits open on start, 10 sec. Pilot proving, MTFI, Post-purge, Non Recycle on flame fail.
- MEP235 Same as MEP230 with lockout on limits open 10 sec. after start, Non Recycle on limits or loss of flame.
- MEP236 Same as MEP230 with 3 sec. additional ignition on with main fuel. For use with intermittent pilot only.
- MEP290 Same as MEP230H with 90 second post purge.
- MEP560 Same as MEP230H with 10 sec. MTFI, Run-Check switch.
- MEP561 Same as MEP560 without pilot stabilization period.
- MEP562 Same as MEP560 with lockout on loss of flame and limit circuit open.



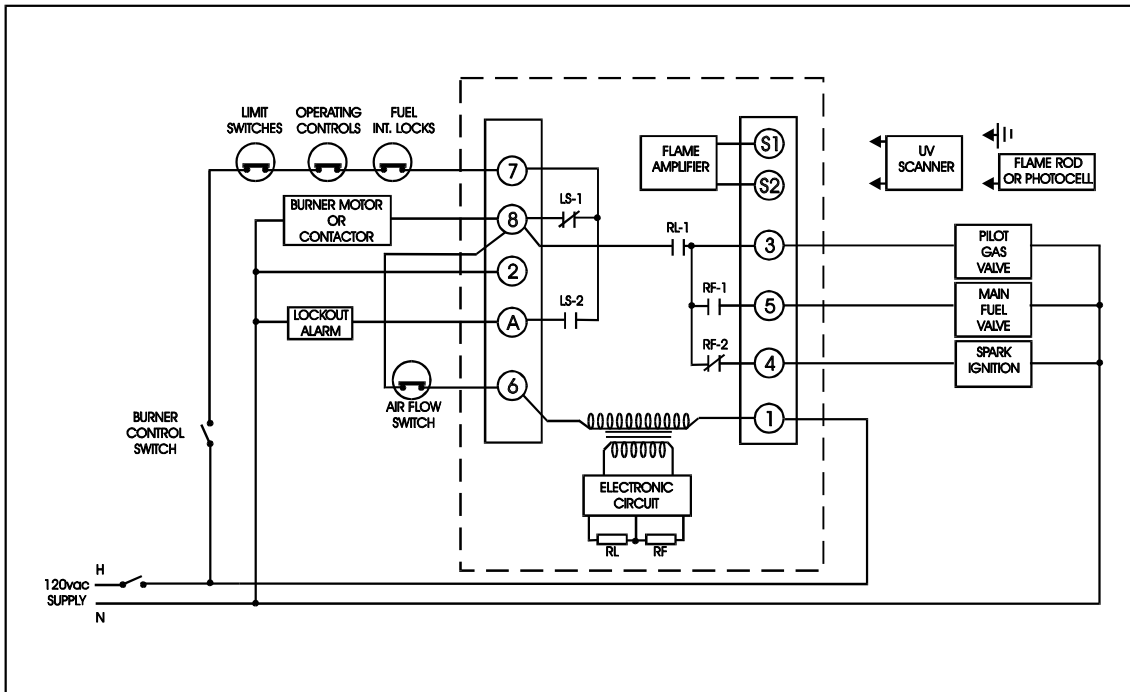
**Fig. 32** Remote reset, communications, and display output are all features located on the “daughter board. Picture shows board with display output only. Note: Micro M has fuse located on chassis.

**Amplifier Modules** are selected based on the type of flame detector and the required FFRT. The following amplifier modules are available:

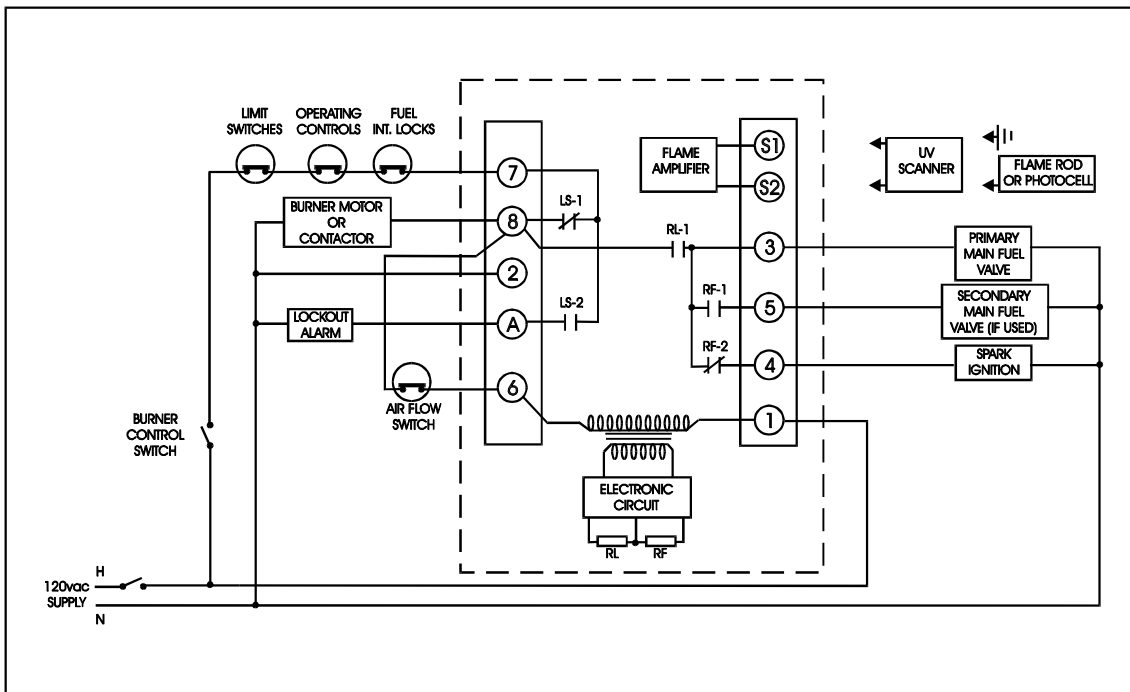
- MEUV1 UV non self check 0.8 sec. FFRT
- MEUV4 UV non self check 3 sec. FFRT
- MEUVS1 UV self check 0.8 sec. FFRT
- MEUVS4 UV self check 3 sec. FFRT
- MERT1 Flame Rod 0.8 sec FFRT
- MERT4 Flame Rod 3 sec FFRT
- MEIR1 Infrared 0.8 sec. FFRT
- MEIR4 Infrared 3 sec. FFRT
- MECD1 Cadmium Sulfide 0.8 sec. FFRT
- MECD4 Cadmium Sulfide 3 sec. FFRT



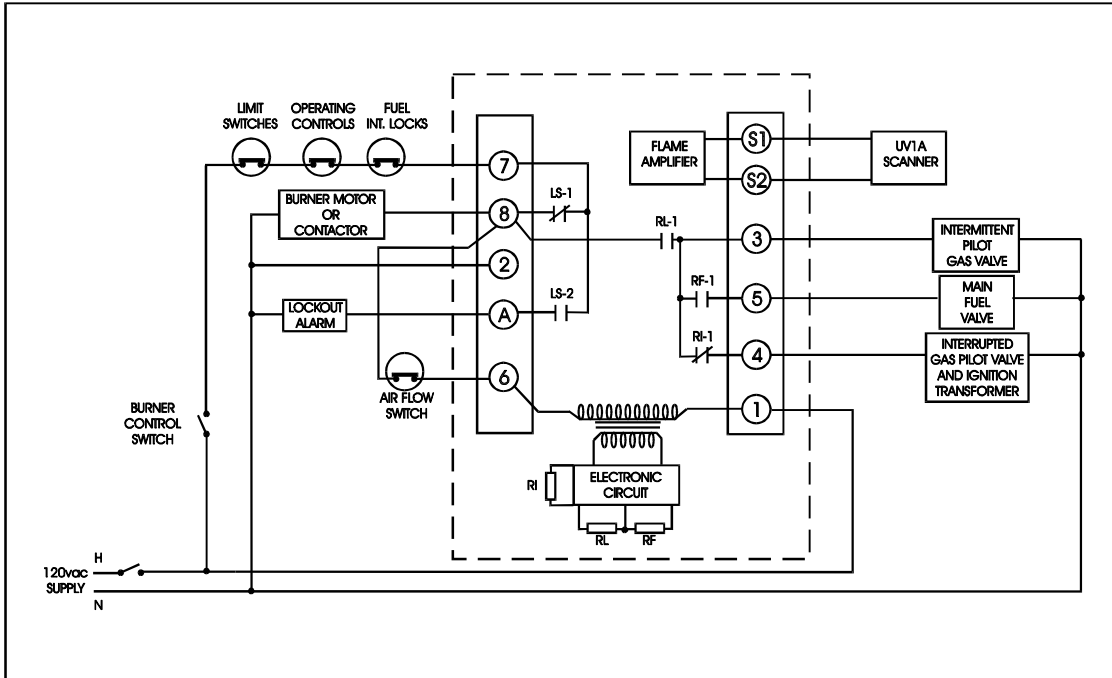
**Fig. 33** Measuring flame signal.



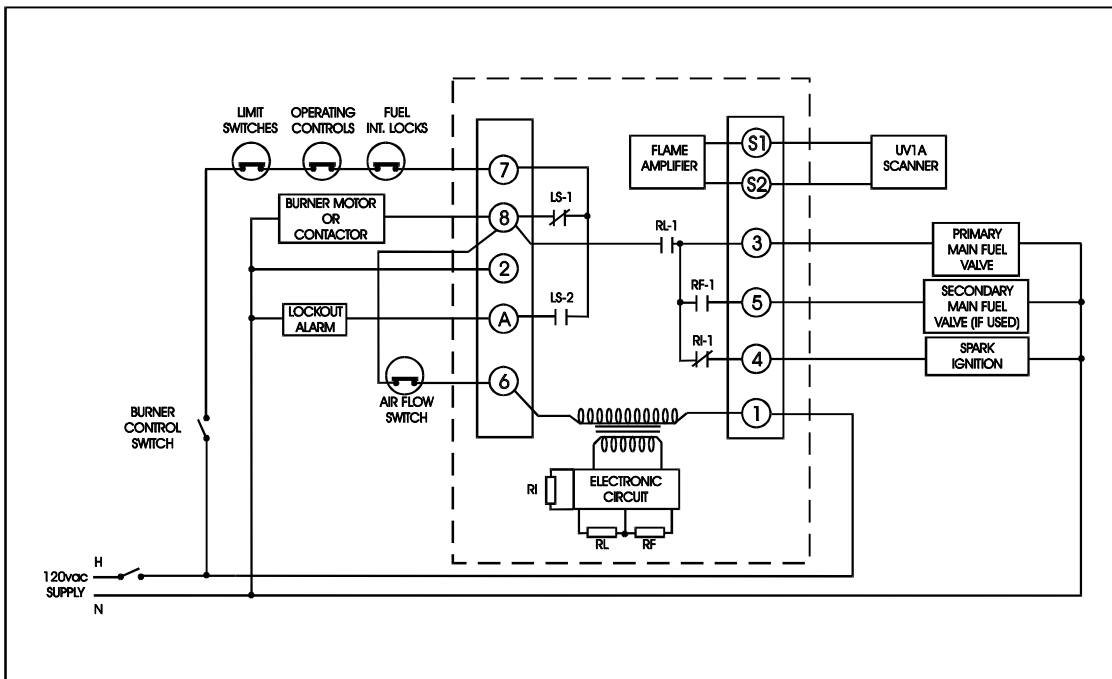
**Fig. 34** Typical wiring arrangement for pilot ignited burner using M series 100 and 200 programmer. Note: For Micro M wire limits between 7 and 6 (not 8 and 6).



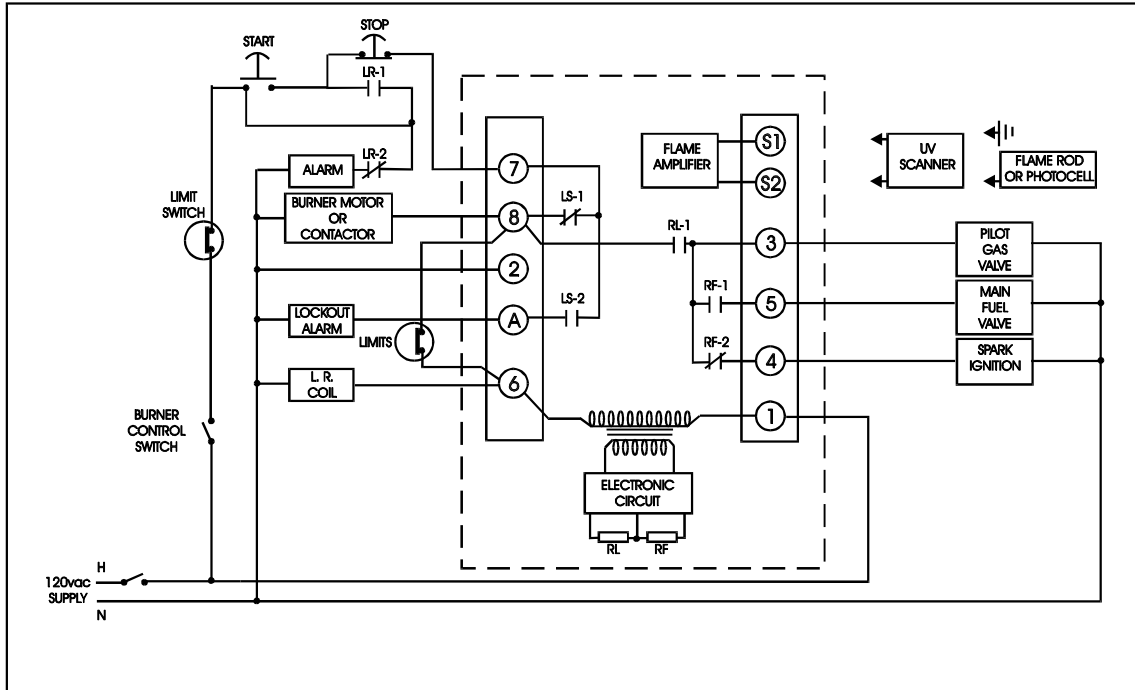
**Fig. 35** Typical wiring arrangement for direct spark ignited burner using M series 100 and 200 programmer. Note: For Micro M wire limits between 7 and 6 (not 8 and 6).



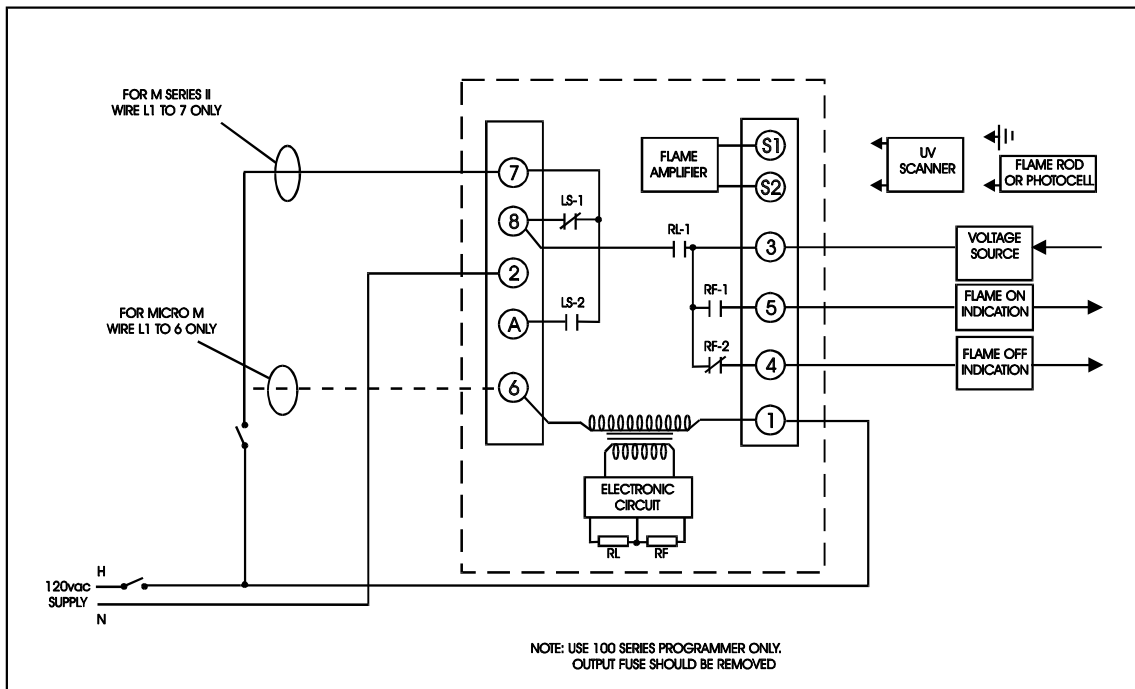
**Fig. 36** Typical wiring arrangement for pilot ignited burner using M series 500 programmer. Note: For Micro M wire limits between 7 and 6 (not 8 and 6).



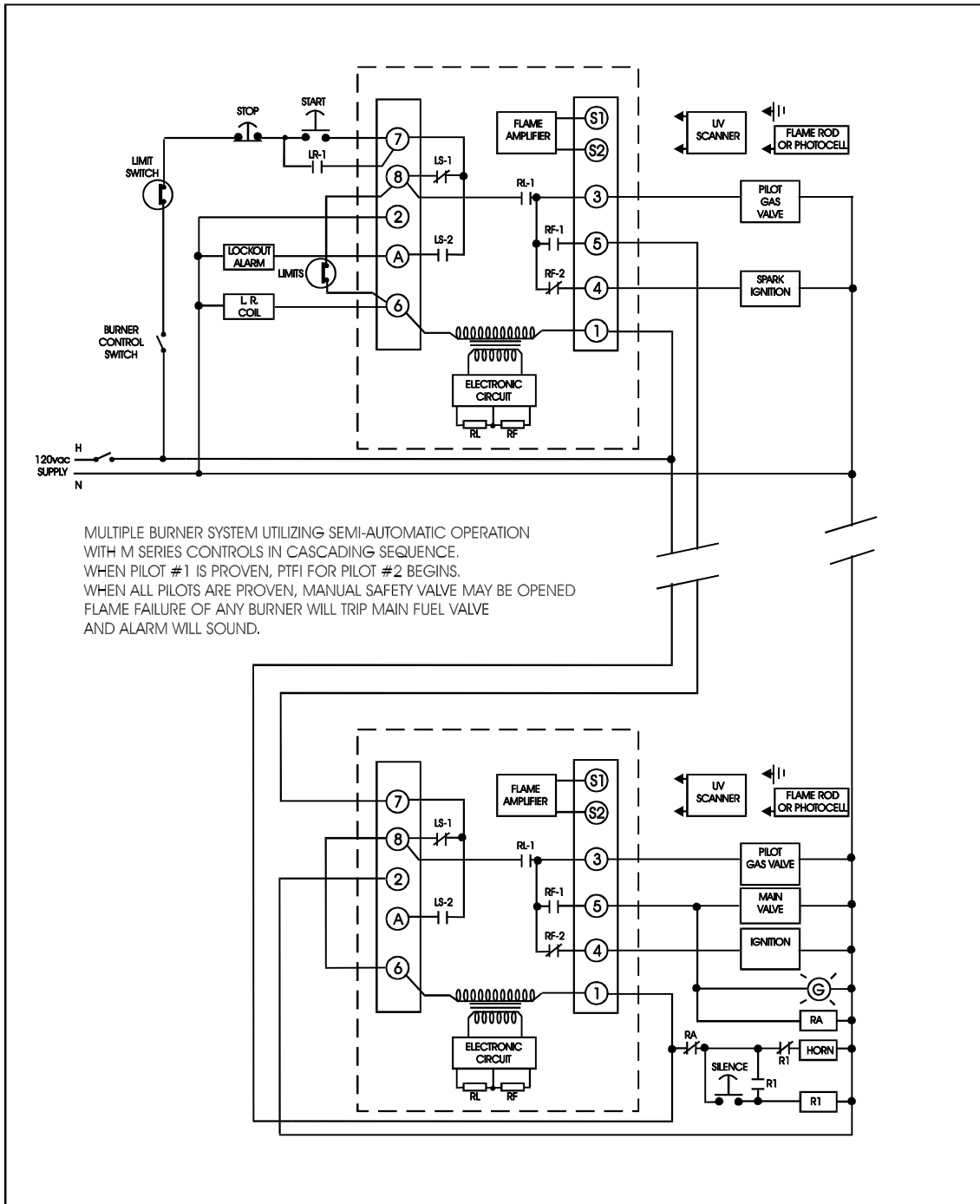
**Fig. 37** Typical wiring arrangement for direct spark ignited burner using M series 500 programmer. Note: For Micro M wire limits between 7 and 6 (not 8 and 6).



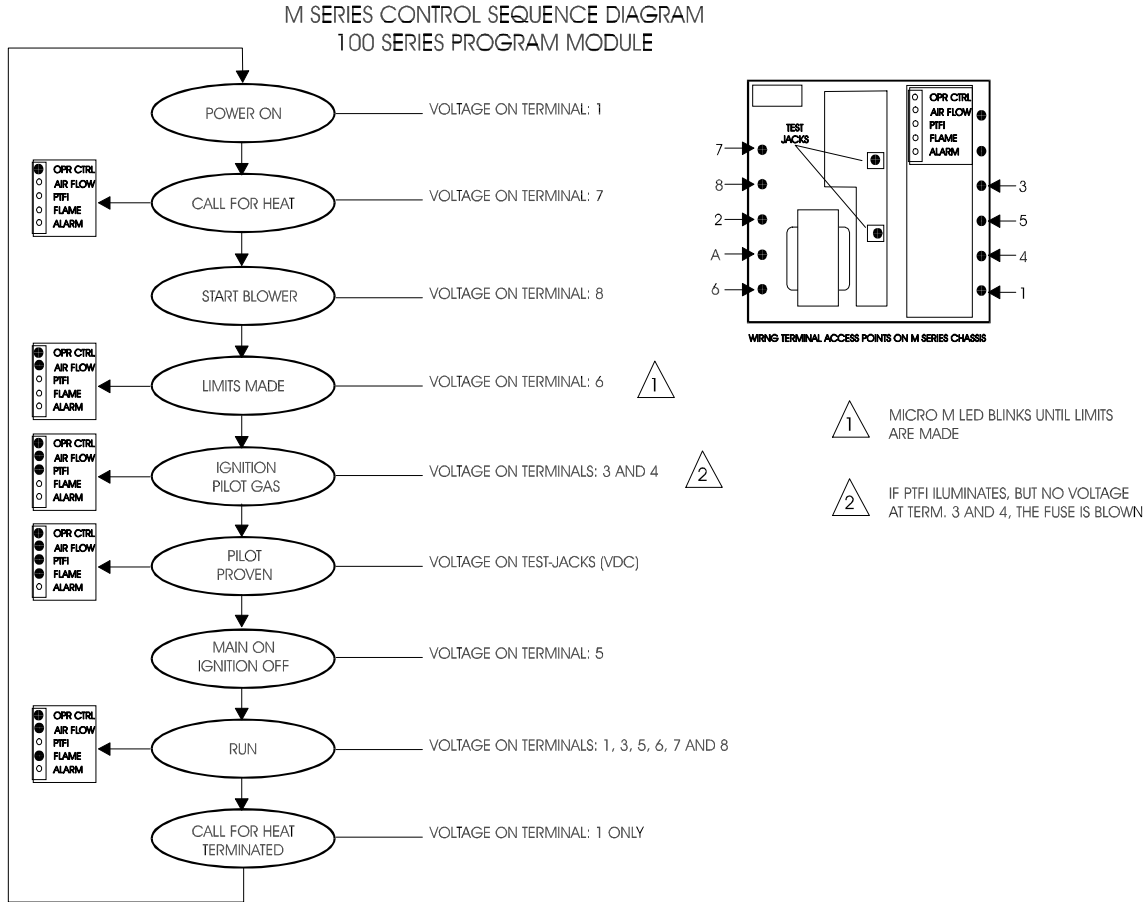
**Fig. 38** *M series control wired for operator to start up each time the burner is fired.*



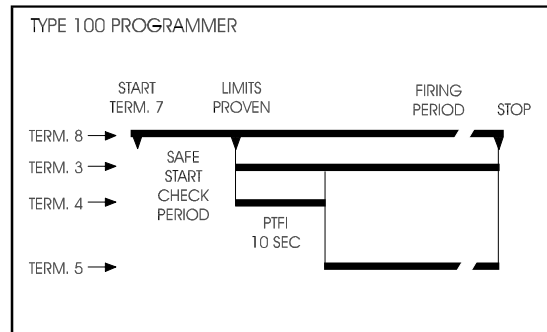
**Fig. 39** *M series control wired as flame switch only.*



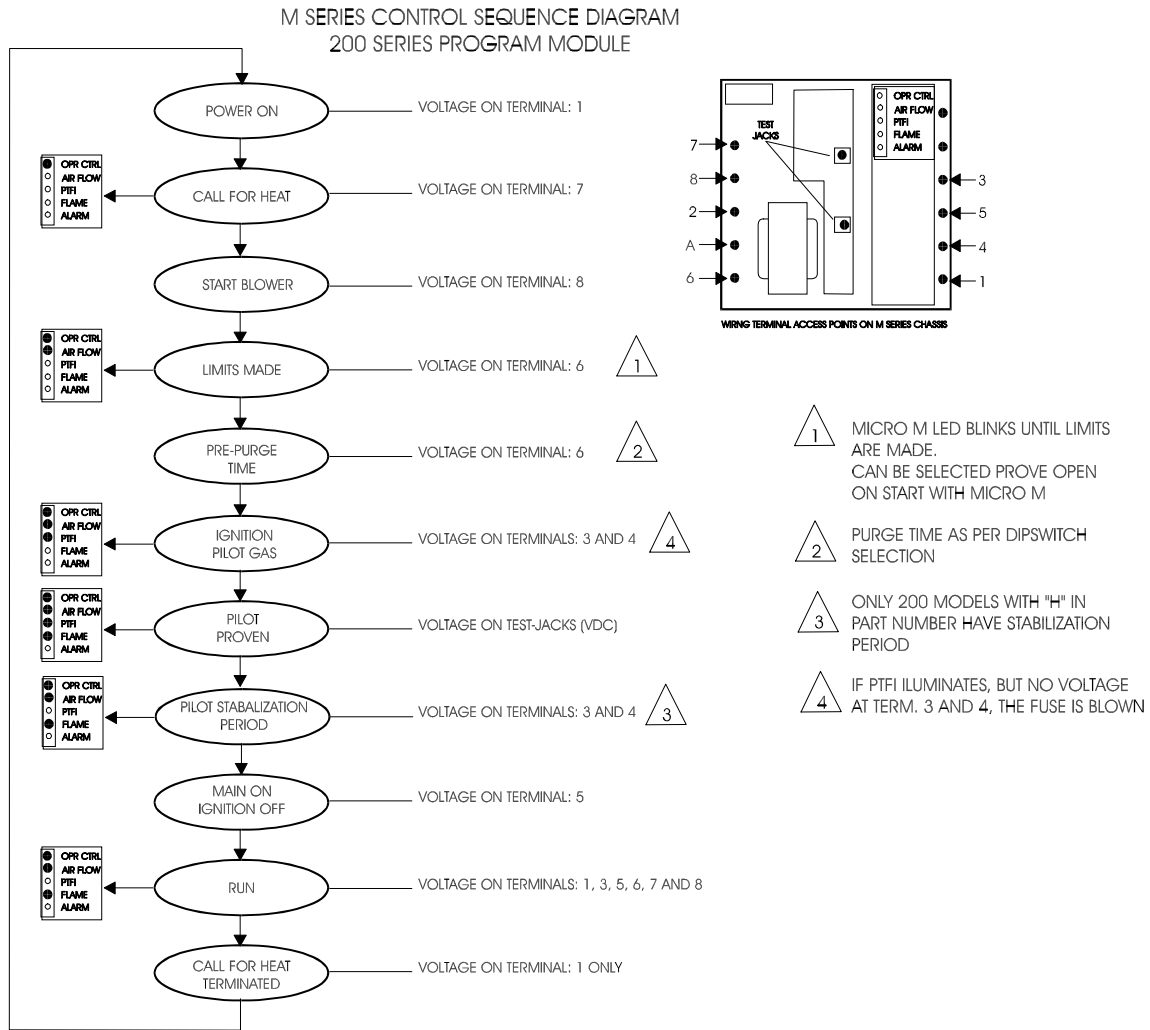
**Fig. 40** M series controls in cascading sequence for multi burner system.



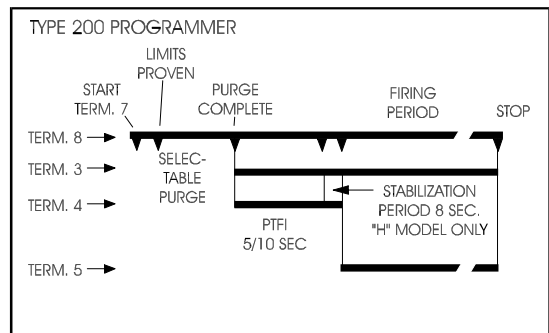
**Fig. 41** Control sequence diagram for M series control with 100 series programmer. Voltage at terminals can be measured as shown when control's cover is removed.

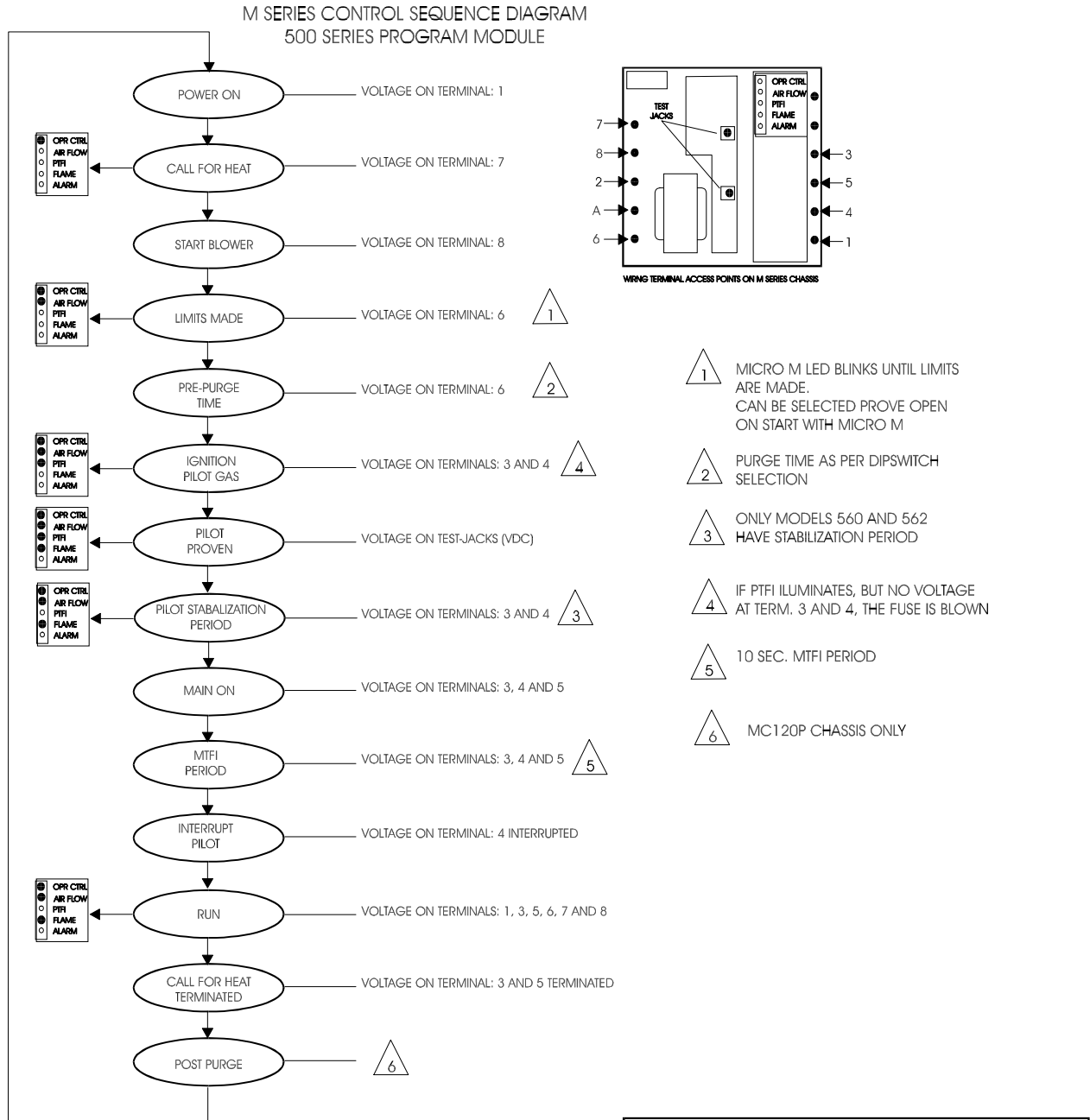




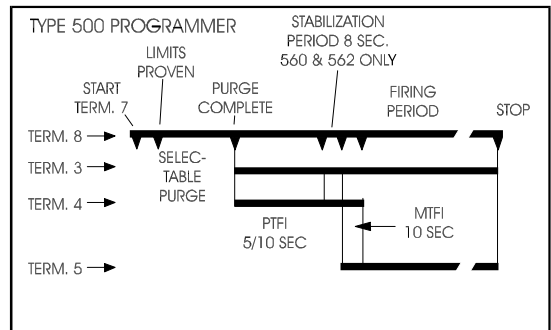


**Fig. 42** Control sequence diagram for M series control with 200 series programmer. Voltage at terminals can be measured as shown when control's cover is removed.





**Fig. 43** Control sequence diagram for M series control with 500 series programmer. Voltage at terminals can be measured as shown when control's cover is removed.





## TROUBLE SHOOTING M SERIES CONTROL

### No voltage at term. L1 – L2

- Electrical supply switched off.
- Blown fuse or tripped breaker.
- Bent Tab on bottom of control.
- Loose connection.
- Wiring error.

### Improper voltage at term. L1 – L2

- Min. operating voltage 102vac
- Max. operating voltage 132vac

### No voltage at term. 7

- Burner on/off switch off.
- Operating or limit control open.
- Loose connection.
- Wiring error.

### Voltage at term. 7 but not term. 8

- Control is in lockout.(Alarm LED on)
- False flame signal detected (Flame LED is on). Check for false flame being detected, or possibly incorrect scanner wiring causing electrical noise.
- Defective UV tube giving false flame signal.
- Defective control chassis.

### Voltage at term. 7 but not term. 6

- Interlock(s) wired between term. 8 and 6 open. (Airflow LED remains off)
- Wiring error.

### Control locks out before prepurge begins.

- Prove Airflow (Term. 8 – 6) open on start is selected “enabled” via its dipswitch.

### It seems prepurge is too long.

- Check dipswitch settings on programmer module.

### PTFI starts, PTFI LED on programmer module lights, but no power on term. 3 & 4.

- Fuse is blown (Inside program module for MC120, on chassis for MEC120 type control).

### Pilot fails to establish, PTFI LED on for 10 seconds, followed by lockout. No visual presence of flame.

- Fuel supply shut off.
- Air in fuel line (needs purging)
- Defective pilot valve.
- Incorrect fuel pressure (check pilot reg.)

- Defective ignition transf. (Check for spark).
- Incorrect spark-gap at igniter assembly.
- Incorrect location of spark electrode tips in relation to pilot burner.
- Incorrect wiring of pilot components.

### Pilot fails to be detected, PTFI LED on for 10 seconds, followed by lockout. Yet visual presence of flame.

- Flame detector not detecting flame.
- Inadequate pilot flame.
- Improper amplifier module installed.
- Flame rod not making contact with flame.
- Defective flame rod. (porcelain)
- Grounding surface of pilot assembly too small (corroded). Replace pilot burner. See page 8
- Incorrect detector wiring.
- (Flame rod system). No ground-path from pilot burner to FSG control. Provide ground wire from control chassis to pilot assembly. Provide ground to terminal S1.
- Flame detector dirty.
- Incorrect line of sight for flame detector.
- Unstable pilot flame.
- Defective flame detector or amplifier module.

### It takes seconds before the pilot flame is detected after pilot valve and ignition transformer are energized.

- Incorrect location of spark electrode tips in relation to pilot burner.
- Incorrect (too high) fuel pressure.
- Incorrect primary air adjustment on pilot burner.

### Main flame fails to establish after PTFI

- Run check switch in “check” (500 series programmer modules only)
- Main, manual shut off valve closed.
- Defective main safety shutoff fuel valve.
- Improper fuel pressure.
- Main valve opening causes fuel pressure limits (high or low) to trip.
- Wiring error to main fuel valve.

### Main flame lights, but goes out when pilot flame is shut off (500 series program modules only)

- Main burns off-ratio. Main fuel pressure too high.
- Main burner improperly adjusted.
- Scanner does not detect main flame.



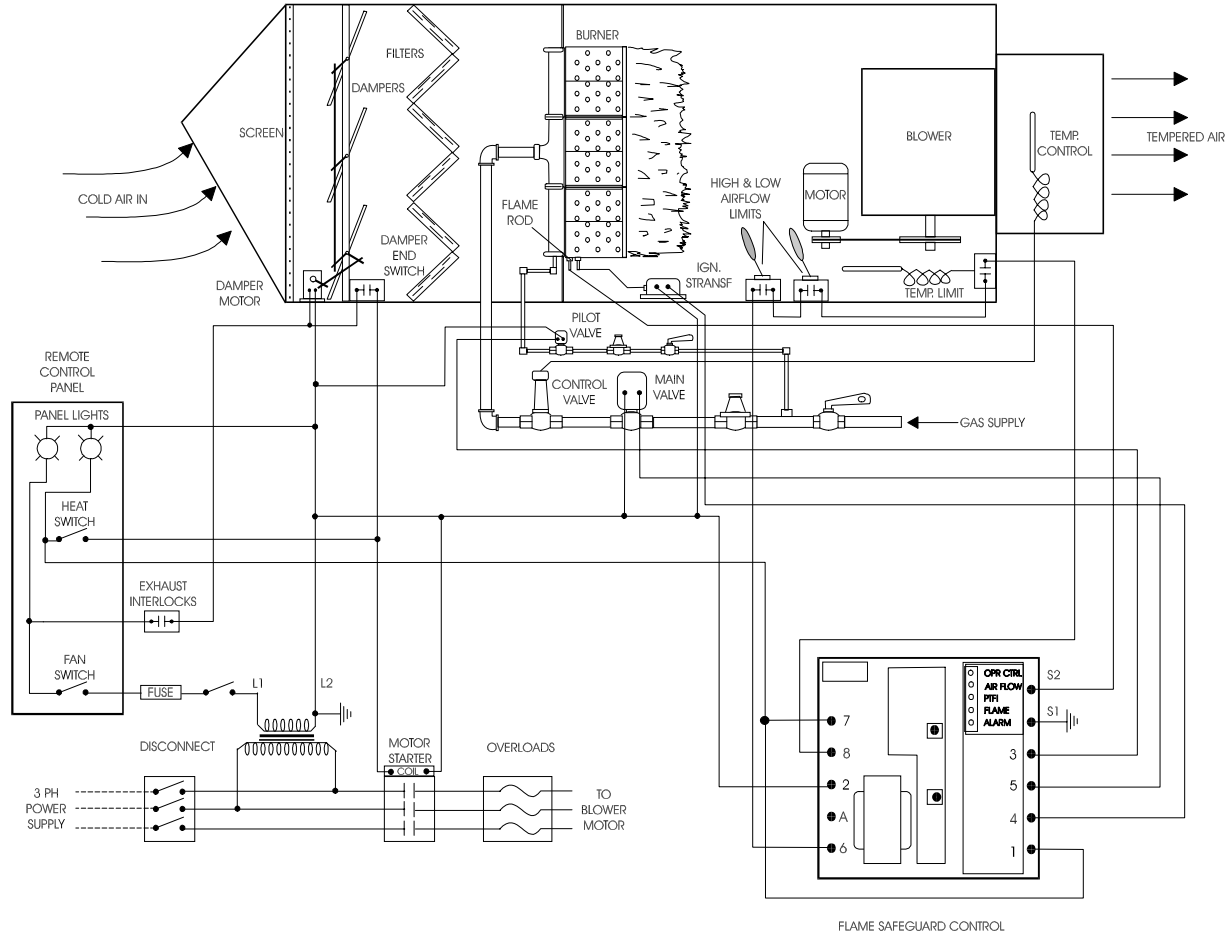
---

**Flame Signal diminishes with time after main burner lights.**

- Main burns off-ratio. Main fuel pressure too high.
- Main burner improperly adjusted.
- Infrared detector saturates. (see page 16)
- Bad UV tube in ultraviolet flame detector.
- Steam atomization blocks flame signal. (UV detector on steam atomized oil burner).  
Reposition detector for more angular view if possible.
- Pilot burner “pulled away” from flame rod by main burner firing. (Flame rod systems on natural draft burners).
- Excessive scanner temperatures.

**Burner locks out on Flame Failure during main flame firing.**

- Main burns off-ratio. Main fuel pressure too high.
- Main burner improperly adjusted.
- Infrared detector saturates. (see page 16)
- Bad UV tube in ultraviolet flame detector.
- Steam atomization blocks flame signal. (UV detector on steam atomized oil burner).  
Reposition detector for more angular view if possible.
- Pilot burner “pulled away” from flame rod by main burner firing. (Flame rod systems on natural draft burners).
- Power spike, unnoticed by FSG but closing fuel solenoid valves.
- Operating, or running interlock limit “weak” causing short drop in voltage, unnoticed by FSG but closing fuel solenoid valves.
- Insufficient grounding to control wiring base when using Micro M control.
- Flame detector wiring in common conduit. Should be in separate conduit.
- Interference by x-rays or extreme sources of electrical noise.
- Defective main safety shutoff valve.
- Defective main gas regulator.



**Fig. 44** Typical application for M series control in a direct fired make up air unit.

Figure 44 is an example of a control wiring arrangement for an air make up unit. Air make up units are generally mounted on the roof of the building and are provided with a remote control panel which is located inside the building for ease of operating the equipment. All other equipment shown is located on the unit.

Fused, 3 phase power is run to a disconnect, which generally is attached to the outside of the unit. From the disconnect, the 3 phase power wires are run to the motor starter/overloads, and on to the blower motor. A step-down transformer provides 120vac control-voltage; L1 (hot) and L2 (neutral). From the transformer, L1 is run through a fuse and connected to the fan switch located in the remote control panel.

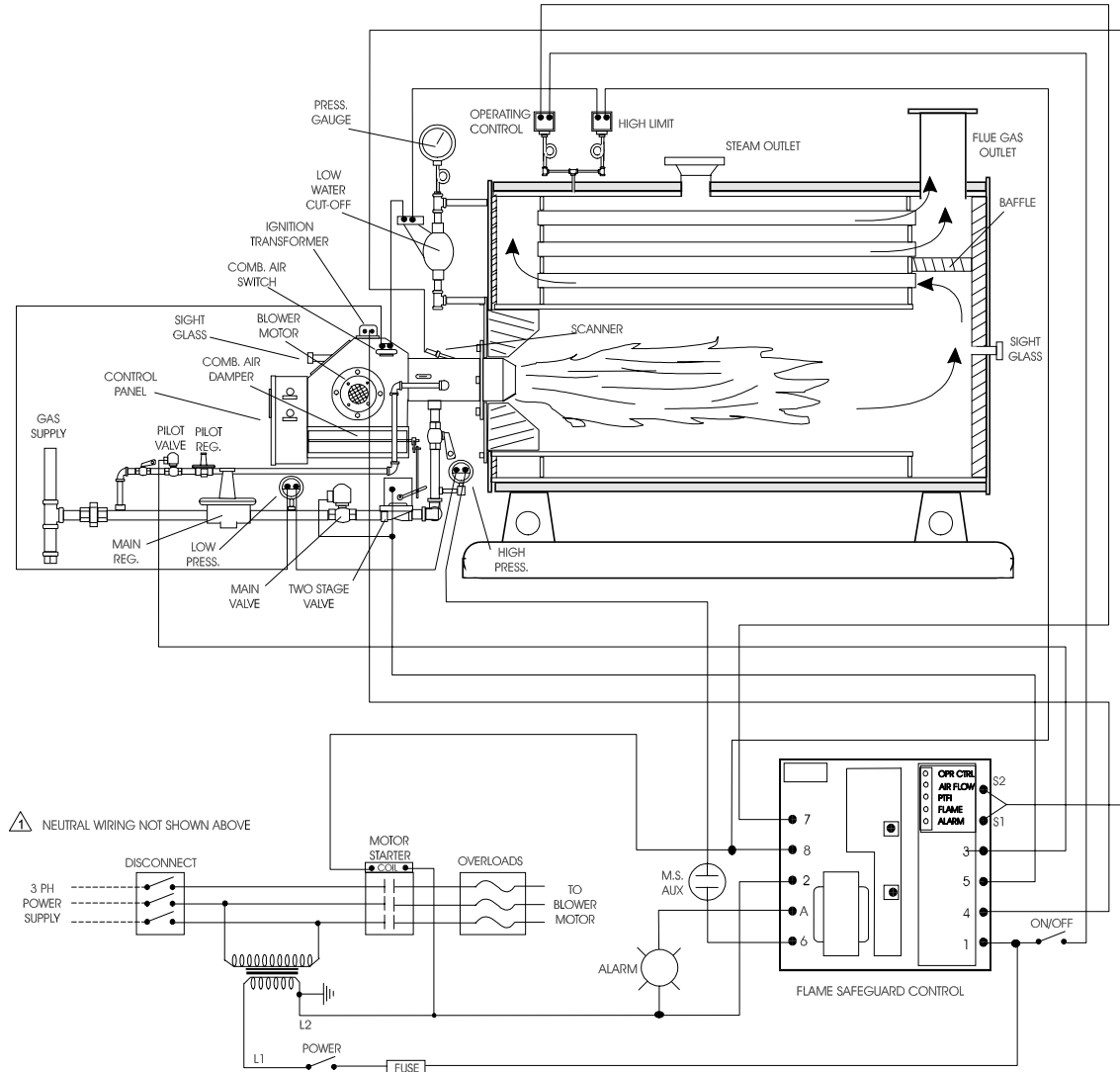
To operate, close the fan switch. The inlet damper motor opens and exhaust interlocks, are checked.

When the dampers are fully open, the damper end-switch closes and will provide voltage to the motor starter coil, starting the blower motor. Outside air is now forced into the building.

To heat the make up air, close the heat switch. This will energize the flame safeguard control by powering its terminal 7 and 1, and a control sequence will begin as described in figure 41

Temperature control is achieved via a direct acting control valve having a capillary tube in the discharge duct.

Prepurge is not required in air make up equipment, as large amounts of air are moved across the burner area at all times.



**Fig. 45** Typical application for M series control on a 3 pass low pressure steam boiler with interrupted pilot and 2 stage firing valve.

Figure 45 is an example of a control wiring arrangement for a small power burner mounted on a steam boiler. Fused control voltage (L1) is wired to terminal 1 from where it is run to the boiler on/off switch. From the switch a wire is run to the boiler operating control and terminated at terminal 7, completing L1 to 7. Running interlocks are shown wired between terminals 8 and 6, some of these such as low water cut-off may be found wired in series with the operating control between terminals 1 and 7. To operate, close the on/off switch. On a call for steam and with other limits wired into the 1 to 7 circuit satisfied, terminal 8 will become energized, starting the combustion air blower.

All limits wired between terminals 8 and 6 must be satisfied and a control sequence will begin as described in figure 43  
Two stage firing control is achieved via separate controller (not shown).



## FIREYE D SERIES

D series flame safeguard controls, in addition to the standard functions of M series flame safeguard control, provide those functions required for fully modulating burners of unlimited capacity. Some of these functions are:

1. Firing rate motor positioning for purge, light-off and run/auto position.
2. Air damper fully open position supervision during purge.
3. Low-fire start-position supervision.
4. Proof of fuel valves closed supervision.
5. Early ignition spark termination.
6. Post purge timings

**Fireeye D series solid-state programming FSG controls** (replaced by E Series, Flame Monitor microprocessor based controls) are comprised of a Chassis, a Programmer, an Amplifier and a Wiring Base. The following is a listing of D Series part numbers and descriptions:



**Fig. 46** D Series control chassis with program module and amplifier installed.

### D Series Chassis

- 70D10 Non recycling  
With modulation terminals
- 70D20 Recycling  
With modulation terminals  
No high purge position supervision.
- 70D30 Recycling  
No modulation terminals  
No high purge position supervision.

### D Series Programmers

- 71D60 30 sec. purge, 10/15 sec. MTFI  
Use with 70D10 and 70D20
- 71D61 30 sec. purge, 10/30 sec. MTFI  
Use with 70D10 and 70D20
- 71D70 30 sec. purge, 10 sec. MTFI  
Use with 70D10 and 70D20  
Early spark cut-off
- 71D80 30 sec. purge, 5/10 sec. MTFI  
Recycles, Use with 70D30
- 71D81 15 sec. purge, 5/10 sec. MTFI  
Recycles, Use with 70D30
- 71D90 90 sec. purge, 5/10 sec. MTFI  
Recycles, Use with 70D30

### D Series Amplifiers

- 72D1R1 Infrared, 2-4 sec. FFRT
- 72D1R1T Infrared, 1 sec. FFRT
- 72D1R3 Infrared, 2-4 sec. FFRT for solid fuel only.
- 72D1R3T Infrared, 1 sec. FFRT for solid fuel only.
- 72DRT1 Flame Rod, 2-4 sec. FFRT
- 72DRT1T Flame Rod, 1 sec. FFRT
- 72DUV1 UV, 2-4 sec. FFRT
- 72DUVS4 UV Self-Check, 2-4 sec. FFRT
- 72DUVS1T UV Self-Check, 1 sec. FFRT

### D Series Wiring Base

- 60-1386-2 Closed wiring base for surface mounting.
- 60-1466-2 Open wiring base for cabinet mounting.

## ASSEMBLY

To assemble a control and its plug-in modules, remove the two module retainer hold-down screws and remove the module retainer.

Note; this retainer cannot be removed while the control is mounted in its wiring base.

Insert the amplifier module in the slot at the left side of the control and gently push into position. Insert the programmer module into the right side of the control and gently push into position.

To mount the unit into its wiring base, the module retainer must be installed.



**Fig. 47** *D Series chassis, module retainer removed, showing insertion of amplifier module.*

## BEFORE INSTALLING THE CONTROL

Before installing the chassis into its wiring base, it is good practice to first do a voltage and short circuit check. First verify that the supply voltage, terminals L1 and L2 is within the specified rating; 120vac 50/60 Hz (132vac max., 102vac min.)

Follow this by a short circuit check. Use a volt meter set on ohms reading lowest scale. **Make sure line voltage power supply to control is off.** Remove the neutral wire from the terminal (L2). If a step-down transformer supplies the control voltage, remove its ground wire from the secondary side neutral also. Clip one meter test lead to the ground terminal located in the wiring base. (The wiring base ground terminal must have a ground wire connected to an earth-ground). With the other test lead make contact with each terminal in the wiring base. At no time should the meter read other than infinity.

Now reconnect the neutral to terminal L2 and remove the test lead from the ground terminal and reconnect this lead to neutral, terminal L2.

Again make contact with the other probe on each terminal in the wiring base. Some terminals may provide resistance readings (coils, transformers, lamps, etc.) these readings should not exceed 5 ohms. A reading of zero ohms on any terminal would indicate a short circuit and must be rectified before installing the control into the wiring base.

Before installing the control into the wiring base, check the electrical tabs on the bottom of the chassis. If they are bent out of position, reposition them with your fingers. The control is shipped with a red tag which has the proper angle marked on it. If the red tag is not available use your own judgment in order to line up each tab uniformly with respect to its neighbor. See figure 48.



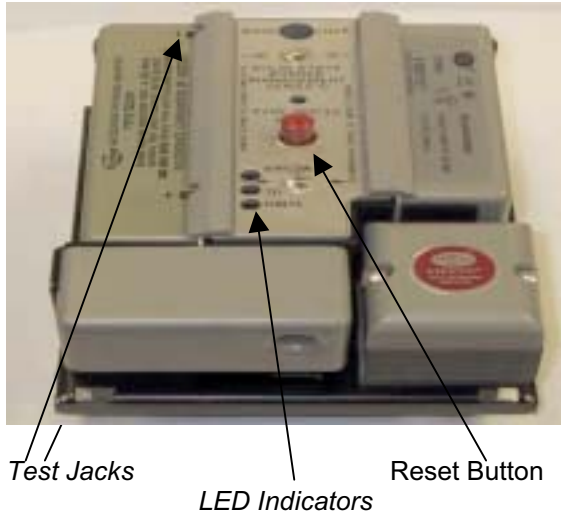
**Fig. 48** *Tabs on bottom of wiring base of D series and Flame Monitor series control.*

With the unit complete, module retainer in place and screwed down, insert the chassis into the wiring base and tighten retaining screw.

Having assured yourself that all interlocks and valves are properly wired and that the sequence of operation is correct, close the manual fuel valves and proceed with checking all safety interlocks for proper shut down of the burner.

Cautiously proceed through a burner light off process.



**Fig. 49**

### LED INDICATOR LIGHTS

A **70D30** control chassis is equipped with three LED indicator lights each of which are labeled:

1. Airflow – Lights when running interlock limits are made (Terminals 3 –P)
2. TFI – Lights during trail for ignition.
3. Fireye – Lights when flame is detected.

A **70D10** and **70D20** control chassis is equipped with five LED indicator lights each of which are labeled:

1. Blower – Lights when blower circuit is energized (Terminal M).
2. Purge – Lights when firing rate motor is driven to high fire (prepurge) position (Terminals 10 – X).
3. TFI – Lights during trail for ignition
4. Fireye – Lights when flame is detected.
5. Auto – Lights when firing rate motor is released to modulate (Terminals 10 – 11).

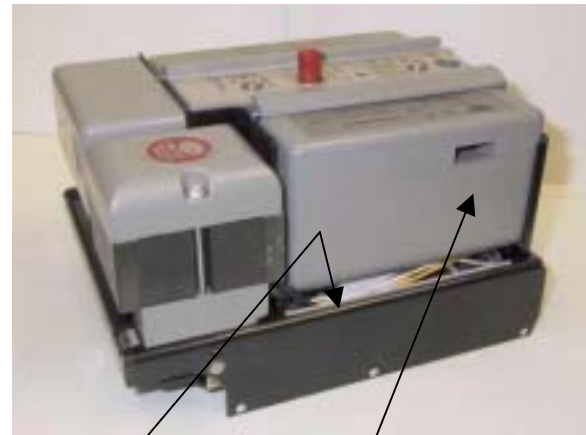
### FLAME SIGNAL STRENGTH

Test Jacks are provided on the front of the amplifier module to accommodate measuring the flame signal strength using a 1,000 ohm/volt (or greater) DC voltmeter, or a digital meter with an input impedance of 500K ohms or greater. Normal flame signal strength reads **18 – 25vdc**  
Flame Relay drop-out is approximately **5vdc**

### RUN CHECK SWITCH

A run check switch is located on the side of the programmer module. A small tool such as a screwdriver is required to operate it.

Putting the switch into the Check position prevents the control from proceeding beyond pilot trial for ignition (PTFI), in fact maintaining pilot until the switch is again placed in the Run position. This allows for adjustment of the pilot flame such as a “Pilot Turn-Down Test” as described on page 18.



Terminal Test-Points      Run Check Switch  
**Fig. 50**

For trouble shooting the control there are voltage test-point for each terminal. These are identified and located on the edge of the chassis board, see figure 50.

When trouble shooting be sure that:

1. Wiring is accordance with instructions
2. Contact tabs on bottom of chassis are not bent out of position.
3. Chassis is firmly secured in wiring base.
4. The Run-Check switch is in the desired position.
5. The correct amplifier module is installed for the flame detector used.
6. The flame detector is clean.
7. The lock-out switch is reset.

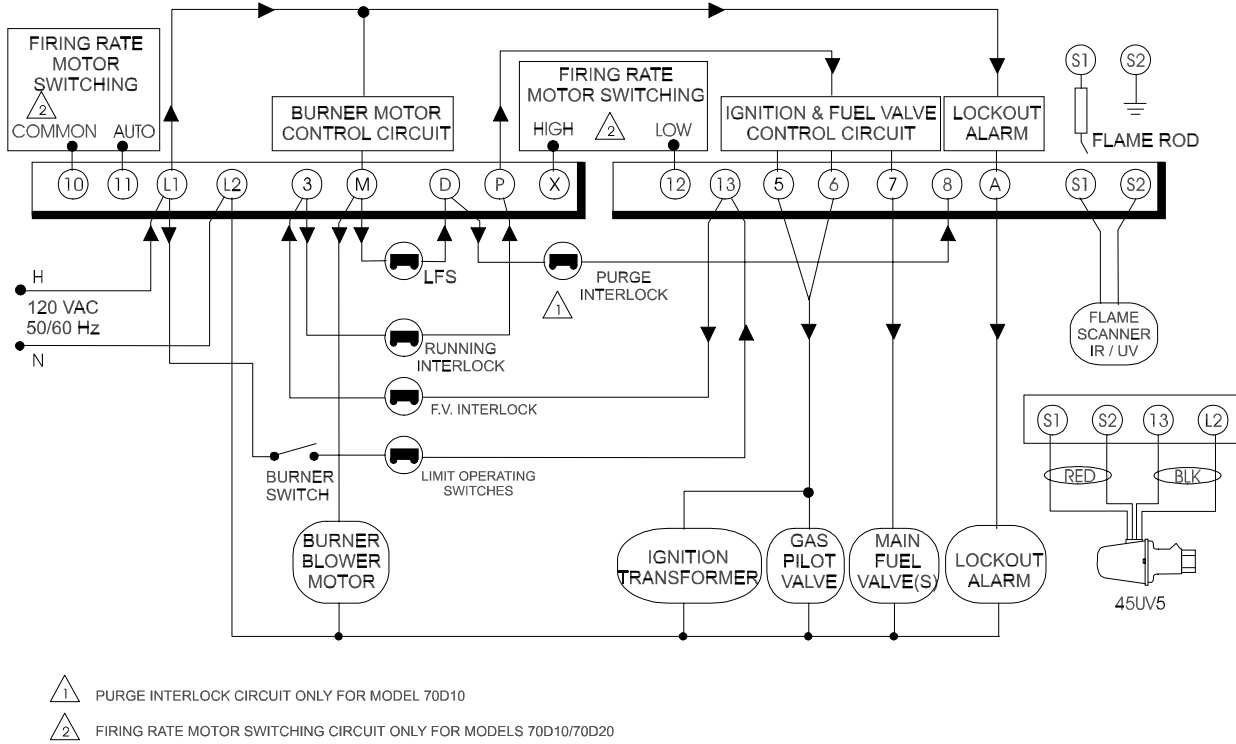


Fig. 51 Wiring schematic for 70D10 and 70D20.

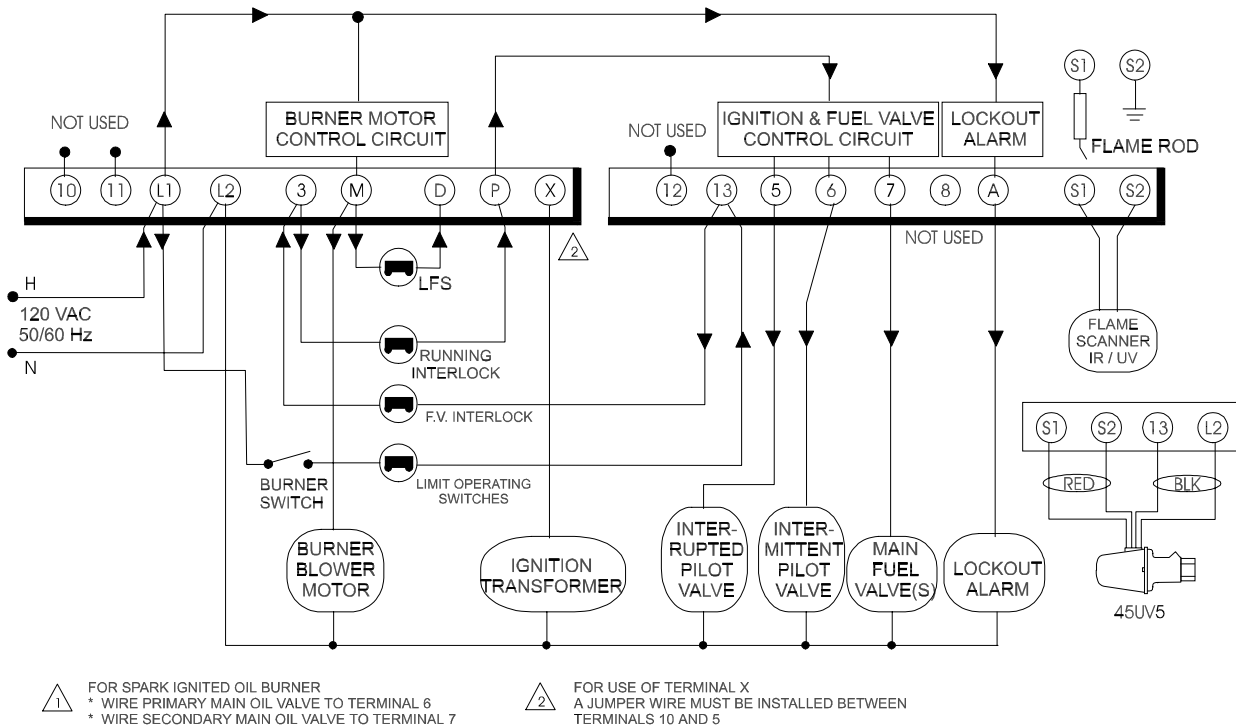
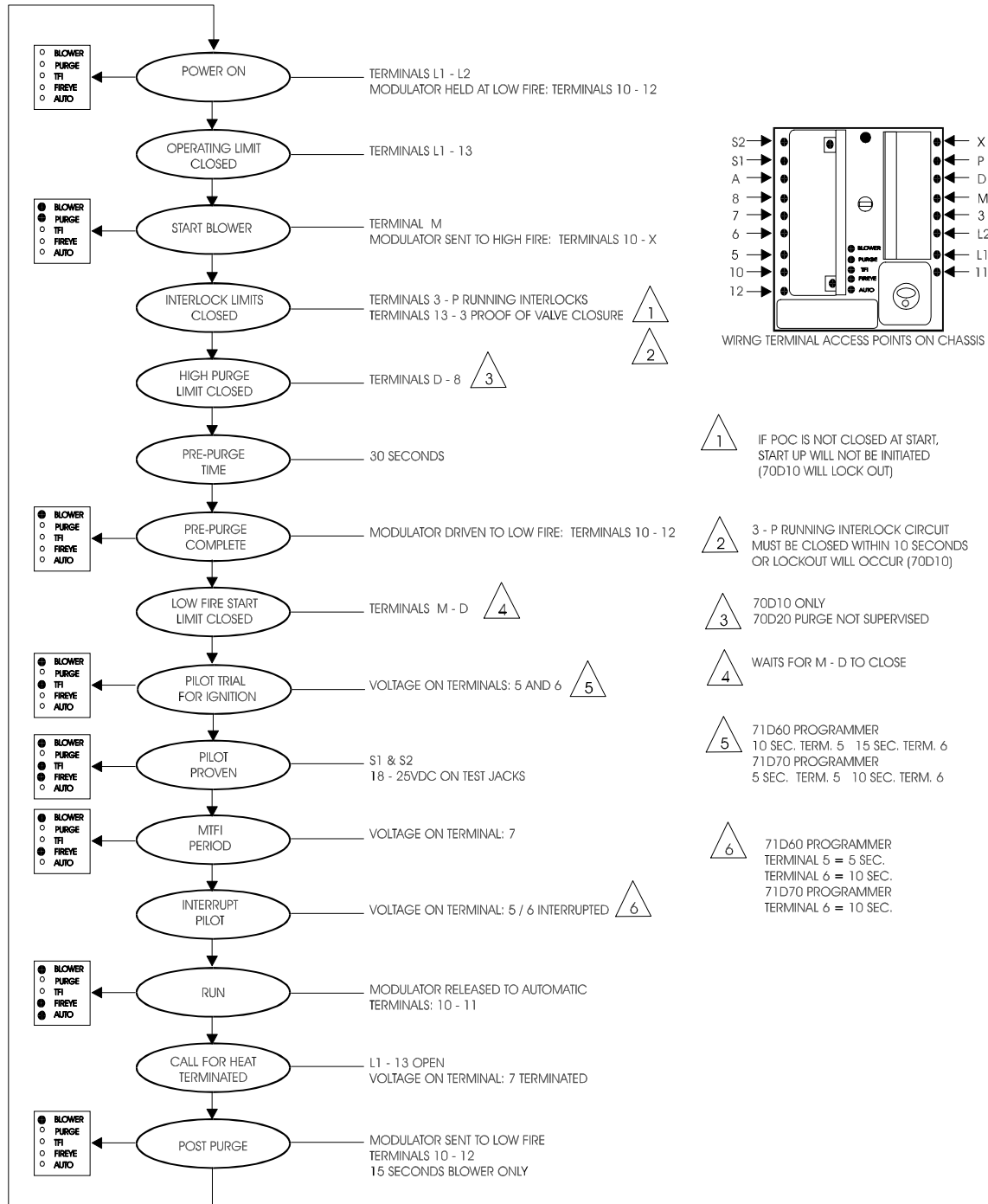


Fig. 52 Wiring schematic for 70D30

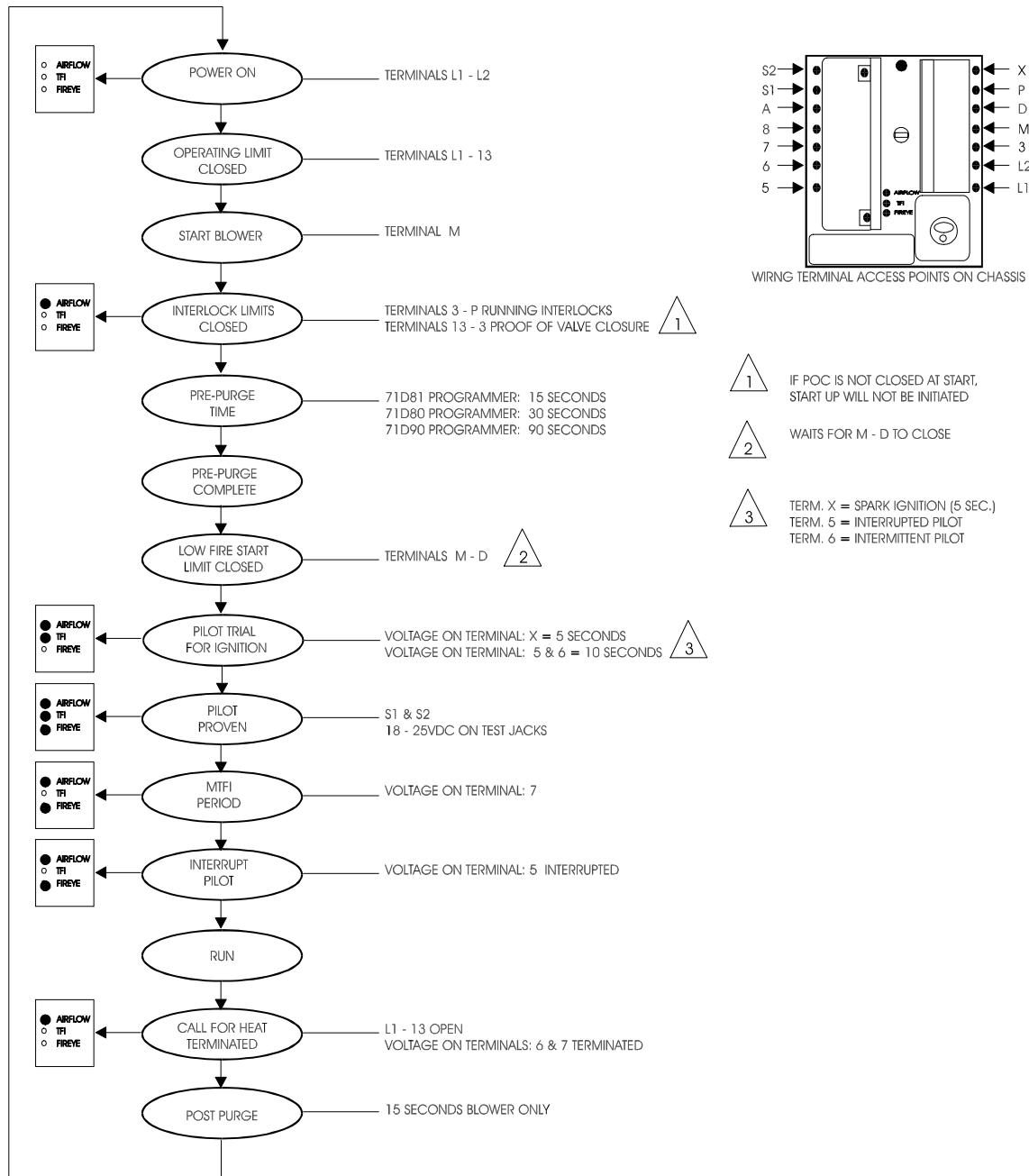
70D10 / 70D20 CONTROL SEQUENCE DIAGRAM



**Fig. 53** Control Sequence Diagram for 70D10 and 70D20 control

Note: In order to measure voltages at wiring terminals, remove the control's cover and measure at access point as shown above.

70D30 CONTROL SEQUENCE DIAGRAM



**Fig. 54** Control Sequence Diagram for 70D30 control

Note: In order to measure voltages at wiring terminals, remove the control's cover and measure at access point as shown above.



## TROUBLE SHOOTING D SERIES CONTROL

### No voltage at term. L1 – L2

#### (All LED's off)

- Electrical supply switched off.
- Blown fuse or tripped breaker.
- Bent tab on bottom of control.
- Loose connection.
- Wiring error.

### Improper voltage at term. L1 – L2

- Min. operating voltage 102vac
- Max. operating voltage 132vac

### No voltage at term. 13

- Burner on/off switch off.
- Operating or limit control open.
- Loose connection.
- Wiring error.

### No voltage at term. 3

#### (All LED's off)

- Fuel valve's "proof of closure" switch open.
- System has no POC switch and no jumper installed at terminals 3 – 13
- Bent tab on bottom of control.

### Blower motor does not start.

#### (Blower and Purge LED's on)

- Control is in lockout.
- Motor three-phase power off.
- Defective motor or contactor.
- Bent tab on bottom of control.
- Defective control chassis.
- If no voltage at term. M, replace chassis.

### Blower runs, but control locks out before end of purge.

#### (Blower, Airflow and Fireye LED's on).

- False flame is detected.
- Check for actual flame being detected.
- Check for incorrect scanner wiring causing electrical noise, causing false signal.
- Defective UV tube giving false flame signal.
- Defective amplifier module.
- 

### Blower runs, purge is not initiated, 70D10 locks out, 70D20 does not.

#### (Airflow LED remains off)

- Interlock(s) wired between term. 3 and P open.
- Wiring error.
- Bent tab on bottom of control.

### 70D10 only: Modulator driven to high, but no further progress in program sequence. (Blower and Purge LED's on).

- High fire purge interlock end-switch not made. Terminals D - 8

### Modulator driven to low, but no further progress in program sequence. (Blower LED on).

- Low fire end-switch not made. Terminals M - D

### PTFI starts, TFI LED on programmer module lights, but no power on term. 5 & 6, Control locks out.

- Replace 70D control chassis.

### Pilot fails to establish, Blower and TFI LED's on for 10 seconds, followed by lockout. No visual presence of flame.

- Fuel supply shut off.
- Air in fuel line (needs purging)
- Defective pilot valve.
- Incorrect fuel pressure (check pilot reg.)
- Defective ignition transf. (Check for spark).
- Incorrect spark-gap at igniter assembly.
- Incorrect location of spark electrode tips in relation to pilot burner.
- Incorrect wiring of pilot components.

### Pilot fails to be detected, Blower and TFI LED's on for 10 seconds, followed by lockout. Yet visual presence of flame.

- Flame detector not detecting flame.
- Inadequate pilot flame.
- Improper amplifier module installed.
- Flame rod not making contact with flame.
- Defective flame rod. (porcelain)
- Grounding surface of pilot assembly too small (corroded). Replace pilot burner. See page 8
- Incorrect detector wiring.
- (Flame rod system). No ground-path from pilot burner to FSG control. Provide ground wire from control chassis to pilot assembly. Provide ground to terminal S2.
- Flame detector dirty.
- Incorrect line of sight for flame detector.
- Unstable pilot flame.
- Defective flame detector or amplifier module.



**It takes seconds before the pilot flame is detected after pilot valve and ignition transformer are energized.**

- Incorrect location of spark electrode tips in relation to pilot burner.
- Incorrect (too high) fuel pressure.
- Incorrect primary air adjustment on pilot burner.

**Main flame fails to establish after PTFI (Blower, TFI and Fireye LED's on)**

- Run check switch in "check" (located in programmer modules )
- Main, manual shut off valve closed.
- Defective main ESD fuel valve.
- Improper fuel pressure.
- Main valve opening causes fuel pressure limits (high or low) to trip.
- Wiring error to main fuel valve.

**Main flame lights, but goes out when pilot flame is shut off. (Blower LED on)**

- Main burns off-ratio. Main fuel pressure too high.
- Main burner improperly adjusted.
- Scanner does not detect main flame.
- 

**Flame Signal diminishes with time after main burner lights.**

- Main burns off-ratio. Main fuel pressure too high.
- Main burner improperly adjusted.
- Infrared detector saturates. (see page 16)
- Bad UV tube in ultraviolet flame detector.
- Steam atomization blocks flame signal. (UV detector on steam atomized oil burner).  
Reposition detector for more angular view if possible.
- Pilot burner "pulled away" from flame rod by main burner firing. (Flame rod systems on natural draft burners).
- Excessive scanner temperatures.

**Burner locks out on Flame Failure during main flame firing.**

- Main burns off-ratio. Main fuel pressure too high.
- Main burner improperly adjusted.
- Infrared detector saturates. (see page 16)
- Bad UV tube in ultraviolet flame detector.
- Steam atomization blocks flame signal. (UV detector on steam atomized oil burner).

Reposition detector for more angular view if possible.

- Pilot burner "pulled away" from flame rod by main burner firing. (Flame rod systems on natural draft burners).
- Power spike, unnoticed by FSG but closing fuel solenoid valves.
- Operating, or running interlock limit "weak" causing short drop in voltage, unnoticed by FSG but closing fuel solenoid valves.
- Insufficient grounding to control wiring base.
- Flame detector wiring in common conduit. Should be in separate conduit.
- Interference by x-rays or extreme sources of electrical noise.
- Defective main safety shutoff valve.
- Defective main gas regulator.

**SPECIFICATIONS:**

Supply Voltage:	120vac (max. 132, Min. 102vac)
Pwr Consumption:	20VA operating
Max. connected load:	2000VA
Temp. Rating:	Max. 125 F, Min. -40 F
Max. load ratings for:	
• Term. 5 & 6 (ind. or combined)	550Va
• Term. 7:	250Va (Pilot duty)
• Term. M:	9.8 F.L.A. 58.8 L.R.A.
• Term. 10-11-12-X:	125Va Pilot duty
• Term. A:	50Va pilot duty

## FLAME MONITOR



**Fig. 55** *Flame Monitor*

The E110, Flame Monitor is a microprocessor based burner management system. It is designed to provide the proper burner sequencing, ignition and flame monitoring protection on automatically ignited oil, gas, and combination fuel burners.

Field inputs are wired into the control's operating and running interlock circuits, and in conjunction with these, the control programs the burner's combustion-air blower-motor, ignition and fuel valves to provide for proper and safe operation of the burner.

One of the strengths of the Flame Monitor system is its ability to display the current operating status plus lockout information in the event of a safety shutdown. The manner in which the information is displayed depends on the type of programmer selected.

The Flame Monitor System is of modular design allowing flexibility in adaptation to various applications. The system consists of a wiring base, control chassis, amplifier module, programmer module, display module and dust cover. The interchangeable aspect of these components provides for complete versatility in selection of control function, timing, and flame scanner means.

Functions such as pre-purge, recycle or not on interlocks, proving of high damper position

during pre-purge and trial for ignition timings are determined by the choice of programmer module. Amplifier modules are selected based on flame detector used.

Main features and benefits of the Flame Monitor include:

- A non-volatile memory, allowing the control to remember its history and present position even when power has been interrupted.
- A constant flame signal readout via display module, or 0 –10 VDC output on the EPD programmer modules.
- Read out of main fuel operational hours and complete cycles via display module.
- Modbus communications via RS485 multi drop link.
- Selectable pre-purge timings, via dipswitch settings.
- A service (Run-Check) switch, allowing the operator to stop the program sequence in any of the three events; Pre-purge, PTFI, or Auto.
- Ability to mount its display module remotely.

### SPECIFICATIONS

Supply voltage: 120 VAC (+10%, -15%)  
50/60Hz

Consumption: 25 VA

Temp. Limits: -40 –to + 125 F  
(Display: 32 to 125 F)

Humidity: 85% R.H. max. non condensing

Terminal load ratings:

- Term. 5 & 6: 550 VA, pilot duty
- Term. 7: 250 VA, pilot duty
- Term. M: 9.8 F.L.A, . 58.8 L.R.A.
- Term. 10,11, 12, X: 125 VA, pilot duty
- Term. A 50 VA, pilot duty



**AMPLIFIER MODULES**



**Fig. 56** Amplifier Module

Amplifier modules used in conjunction with the Flame Monitor System are selected based on the type of flame detector. The amplifier module is installed in the third set of guide channels found in the Flame Monitor Chassis, where it is clearly marked “Amplifier Module”. There is a total selection of six amplifier modules. The following table assists in clarifying the specifics of each.

Fireye Part Number	Description	Use with Scanner
EUV1	UV non self check amplifier	UV1A UV8A 45UV3
EUVS4	UV self check amplifier	45UV5-1007 45UV5-1008 45UV5-1009
E1R1	Autocheck infrared amplifier	48PT2
E1R2 (See note 1)	Autocheck infrared amplifier For special applications. Consult factory	48PT2
E1R3 (See note 2)	Autocheck infrared amplifier Without oil fog rejection	48PT2
ERT1	Rectification amplifier	45CM1 69ND1

**Note 1:**

The E1R2 has increased sensitivity, which may result in unsafe operation if not properly applied. Increased sensitivity implies that far less infrared radiation intensity is required as received from the flame envelope to be accepted as flame on. Only special applications can operate safely with this amplifier. Consult factory before using.

**Note 2:**

The E1R3 does not provide oil spray rejection protection, which may result in unsafe operation if not properly applied. Oil Spray Rejection implies that the system responds to any significant change in level of flame-brightness, such as a flame out condition where oil continues to be sprayed in front of bright, hot refractory. Consult factory before using.





FIREYE PART NUMBER	PRE-PURGE PROGRAMMING SECONDS 2	PROVEN HIGH FIRE PURGE INTERLOCK (D/8 Ckt)	PROVEN LOW FIRE PURGE INTERLOCK (M/D Ckt)	INTERMITTENT IGNITION / PILOT	INTERRUPTED IGNITION PILOT	EARLY SPARK TERMINATION	PILOT TRIAL FOR IGNITION		MAIN TRIAL FOR IGNITION		RUNNING INTERLOCK 3/P Ckt	FIRING RATE MOTOR CIRCUIT	FLAME FAILURE RESPONSE TIME (FFRT)
							TERM 5	TERM 6	TERM 5	TERM 6			
EPD160 EP160 EPD167 <sup>8</sup>	30 1 SUPERVISED	YES	YES	NO	YES	NO	10 10	10 15	NON RECYCLE	YES	4		
EPD161 EP161	30 1 SUPERVISED	YES	YES	NO	YES	NO	10 10	10 30	NON RECYCLE	YES	4		
EP163	30 9 SUPERVISED	YES	YES	NO	YES	NO	5 5	5 5	NON RECYCLE	YES	4		
EPD165 EP165 <sup>7</sup>	30 1 SUPERVISED	YES	YES	NO	YES	NO	10 10	---	NON RECYCLE	YES	2		
EPD166 EP166	30 1 SUPERVISED	YES	YES	NO	YES	NO	10 10	---	NON RECYCLE	YES	2		
EPD170 EP170	30 1 SUPERVISED	YES	YES	NO	YES	YES	5 10	---	NON RECYCLE	YES	4		
EPD260 EP260	30 1	NO	YES	NO	YES	NO	10 10	10 15	RECYCLE	YES	4		
EPD261 EP261	30 1	NO	YES	NO	YES	NO	10 10	10 30	RECYCLE	YES	4		
EPD265 EP265	30 1	NO	YES	NO	YES	NO	10 10	---	RECYCLE	YES	2		
EPD270 EP270	30 1	NO	YES	NO	YES	YES	5 10	---	RECYCLE	YES	4		
EPD380 EP380	30	NO	YES	YES <sup>3</sup>	YES	4 YES	10 10	10 3	RECYCLE	NONE	4		
EPD381 EP381	15	NO	YES	YES <sup>3</sup>	YES	4 YES	10 10	10 3	RECYCLE	NONE	4		
EPD382 EP382	0	NO	YES	YES <sup>3</sup>	YES	4 YES	10 10	10 3	RECYCLE	NONE	4		
EP383	30 11	NO	YES	YES <sup>3</sup>	YES	4 YES	15 11 15	10 11 15	RECYCLE	NONE	4 11		
EPD390 EP390	90	NO	YES	YES <sup>3</sup>	YES	4 YES	10 10	10 3	RECYCLE	NONE	4		

ALL PROGRAMMERS HAVE A MAXIMUM 4 SECOND FLAME FAILURE RESPONSE TIME WITH THE EXCEPTION OF THE EP165, EP166 AND EP265 (2 SEC.)  
ALL EPD AND EP PROGRAMMERS HAVE SELECTABLE 3 TO P "PROVE OPEN ON START" FEATURE VIA DIPSWITCH.

- 1 PROGRAMMER ADDS 30 SECOND AFTER PRE-PURGE TO ALLOW DAMPER MOTOR TO DRIVE TO LOW FIRE POSITION
- 2 PUGE TIMINGS CAN BE EXTENDED VIA THE DIPSWITCHES LOCATED ON THE PROGRAMMER MODULE
- 3 EP380, EP381, EP382 AND EP390 HAVE SELECTABLE INTERMITTENT OR INTERRUPTED (15 SEC.PTFI) OPERATION OF TERM. 6 VIA DIPSWITCH
- 4 THESE PROGRAMMERS CAN USE TERM. X FOR SPARK TERMINATION. REQUIRES TERMS 10 AND 5 TO BE JUMPERED
- 5 EP380, EP381, EP382 AND EP390 HAVE SELECTABLE RECYCLE OR NON RECYCLE OPERATION VIA DIPSWITCH
- 6 DURING MTFI, TERMINAL 6 IS ENERGIZED FOR 5 SECONDS, BEFORE MTFI (10 SEC.) FOR EP165 AND EP265, (15 SEC) FOR EP166 ONLY
- 7 EP165 LOCKS OUT ON POWER INTERRUPTION
- 8 THE EPD167 WAITS INDEFINITELY FOR THE LOW FIRE START SWITCH (M - D) TO CLOSE
- 9 THE EP163 PURGE AND IGNITION TIMINGS ARE PROGRAMMABLE VIA THE ED510 DISPLAY MODULE
- 11 THE EP383 PURGE, IGNITION, FFRT AND POST-PURGE TIME IS PROGRAMMABLE VIA THE ED510 DISPLAY MODULE
- 12 INTERMITTENT OR INTERRUPTED PILOT OPERATION MAY BE SELECTED VIA DIPSWITCH (OR VIA ED510 DISPLY MODULE, WITH EP383)

**Fig. 57 Flame Monitor Programmer selection chart**

Programmers for the Flame Monitor system are designated with prefix "EP" or "EPD".

**PROGRAMMERS**

The programming module is the hearth of the system. Figure 57 represents a chart of the most common programmers and lists the programming sequence.

Note that programming functions in the sequence may be selectable via dipswitches located on the module.

**EP** programmers are designed to receive the ED510 display module "snapped into the face of the module.

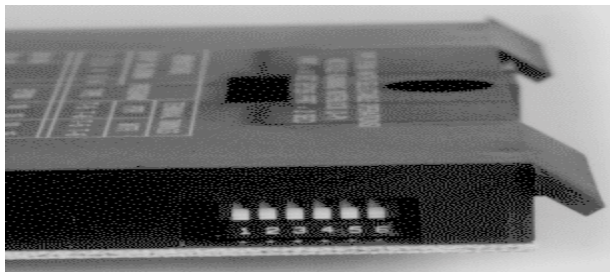
**EPD** programmers are designed with an integral LED display and are compatible to be used with an additional remotely mounted ED510 display module.



DIPSWITCH NUMBER						PROGRAMMER TYPE	TERMINAL TIMINGS			
							PTFI		MTFI	
1	2	3	4	5	6		TERM 5	TERM 6	TERM 5	TERM 6
NOT ACTIVE						EP160 EP260	10	10	10	15
						EP170 EP270	5	10	---	10
DIPSWITCH POSITION						EP161 EP261	10	10	10	30
						EP165 EP265	10	10	---	10 1
						EP166	10	10	---	15 2
						30 SEC.	SELECTABLE PREPURGE TIMING		NOTE: A 30 SECOND LOW FIRE PURGE IS ADDED TO THE SELECTED PURGE TIME	
						60 SEC.				
						90 SEC.				
						2 MIN.				
						5 MIN.				
						10 MIN.				
						15 MIN.				
						30 MIN.				
						PROVE 3 - P OPEN	DISABLED			
						PROVE 3 - P OPEN	ENABLED			
1 EP165 / EP265: DURING MTFI, TERM. 6 REMAINS ENERGIZED FOR 5 SEC. (PILOT STABILIZATION) BEFORE ENERGIZING TERM. 7 (FOR 10 SEC.)										
2 EP166: DURING MTFI, TERM. 6 REMAINS ENERGIZED FOR 5 SEC. (PILOT STABILIZATION) BEFORE ENERGIZING TERM. 7 (FOR 15 SEC.)										

DIPSWITCH NUMBER						FUNCTION	
1	2	3	4	5	6		
DN						RECYCLE ON 3 - P LIMITS OPEN	
UP						NON RECYCLE ON 3 - P LIMITS OPEN	
	DN					INTERMITTENT PILOT ON TERMINAL 6	
	UP					INTERRUPTED PILOT ON TERMINAL 6	
DIPSWITCH POSITION							
						1 SEC. -----EP382	
						5 SEC.	
						15 SEC. -----EP381	
						30 SEC. -----EP380	
						90 SEC. -----EP390	
						2 MIN.	
						5 MIN.	
						10 MIN.	
						PROVE 3 - P OPEN	DISABLED
						PROVE 3 - P OPEN	ENABLED
DIPSWITCHES ARE NOT ACTIVE ON PROGRAMMERS; EP383, EP390WR AND EP390WN							

**Fig 58** Description of programmer dipswitch functions. Upper chart is for EP100 and EP200 series, lower chart is for EP300 series.



**Fig 59** Dipswitch location

Figure 58 shows dipswitch functions for all programmer modules.

Figure 59 shows the location of the dipswitches on the programmer. Note that indications “DN” and “UP” in figure 58 relates to DOWN and UP for the switches as shown in figure 59

A further detailed description of the usage of the dipswitches can be found on the next page.

UP

DOWN



## DIPSWITCHES

Several operational characteristics of the EP160, Ep161, EP165, EP166 and EP170 programmer modules are determined by six dipswitches located on the side of the programmer. These characteristics include purge timing (dipswitches 3, 4, 5). The dipswitches are also used to select the option of proving the 3 - P running interlock open at the start of the each operating cycle, which includes that the high purge interlock (D - 8) and low fire start interlock (M - D) are switching open and closed at the appropriate times (dipswitch 6).

**Note: All dipswitch functions become PERMANENT after the control has been powered for more than eight (8) hours. After this "Burn-In" period changing the position of any dipswitch will not have any effect on the operation of the programmer module.**

Figures 58 and 59 show dipswitch location and functions.

**Dipswitches 1 and 2 are inactive on EP100 and 200 series programmers.**

The EP300 series programmer utilizes **dipswitch 1** to determine if the programmer will recycle, or not, when the running interlock circuit (terminals 3 - P) opens during the firing cycle. The programmers are shipped with the switch in the "Recycle" (switch down) position.

The EP300 series programmer utilizes **dipswitch 2** to select "Intermittent or Interrupted" operation of terminal 6 (Pilot or first stage valve). When selected for intermittent operation, terminal 6 remains energized throughout the firing period. When selected for interrupted operation, terminal 6 is energized for 10 seconds during PTFI and 15 seconds during MTFI before de-energizing. These programmers are shipped with dipswitch 2 in the down position (Intermittent operation).

## PRE-PURGE TIMING

**Dipswitches 3, 4 and 5 are for pre-purge timings.**

Purge timings are selectable as per the charts shown in figure 58.

Note that (only) on the EP100 series programmers the selected purge timing is not initiated until the firing-rate motor is driven to (terminals 10 - X made), and proven at (terminals D - 8 closed), **the high purge position.**

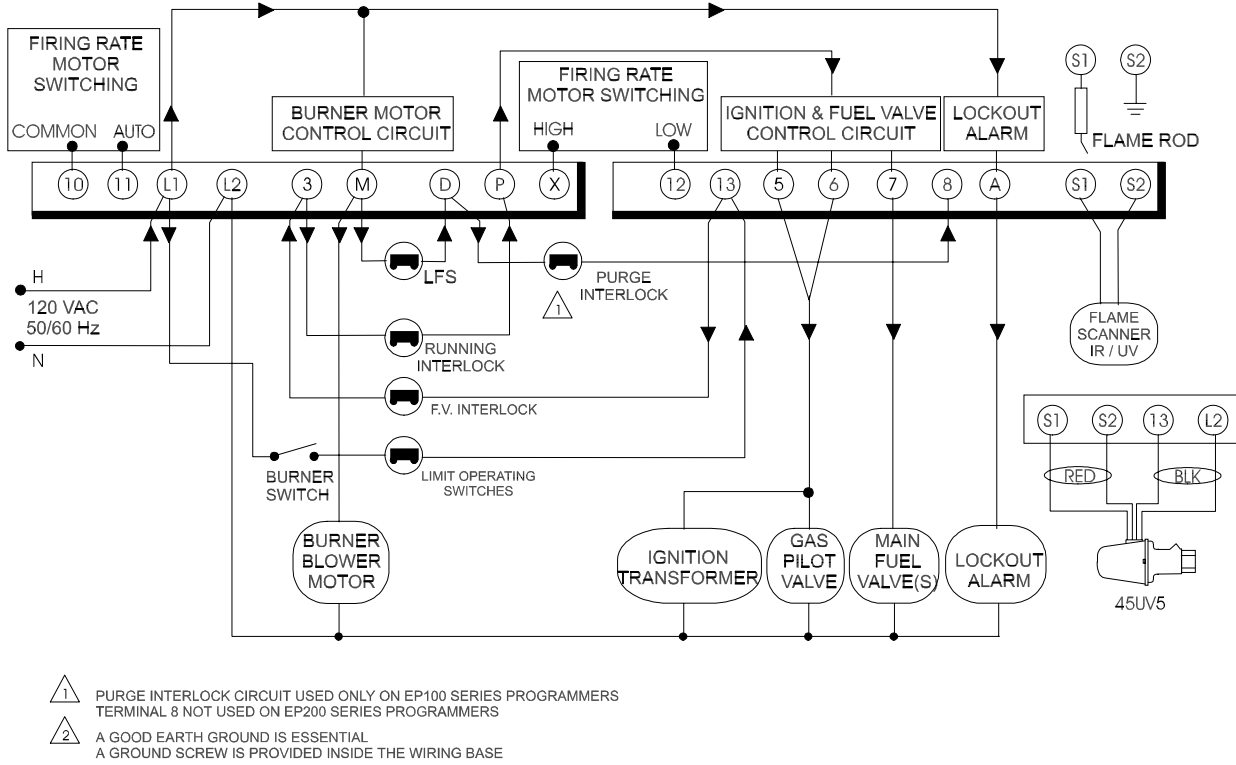
At the end of the pre-purge timing (EP100 and 200 series only), the firing rate motor is driven to the low fire (light-off) position (10 - 12 made). **EP100 and 200** series programmers will add a minimum 30 seconds (maximum 10 minutes) to the pre-purge timing, waiting for low fire start switch to be proven closed.

**EP300** series programmers do not have firing rate motor circuit control. These programmers do not prove high fire purge position and do not have a minimum wait period for low fire start switch to close (PTFI is initiated immediately after selected prepurge period is completed and low fire end switch is made).

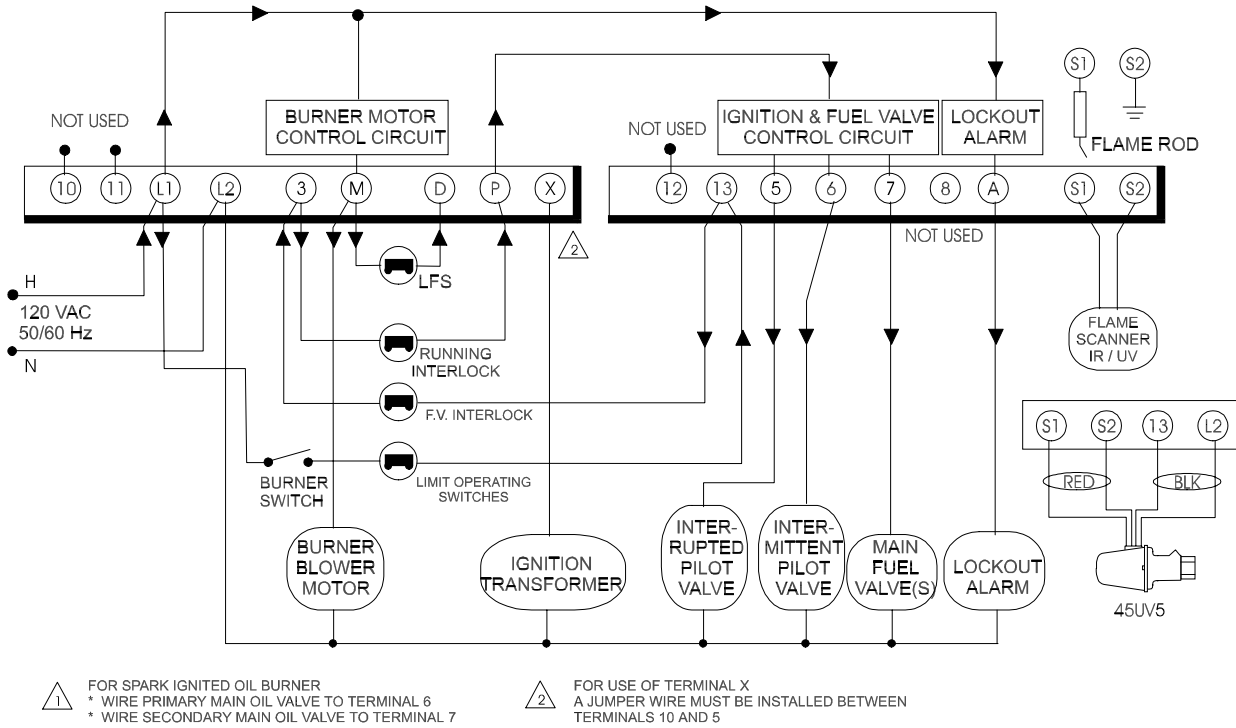
## PROVING THE RUNNING INTERLOCK CIRCUIT (3 - P) OPEN ON START.

**Dipswitch 6** provides the option to prove the running interlock circuit (terminals 3 - P) open at the start of the each operating cycle, **which also includes that the high purge interlock (D - 8) and low fire start interlock (M - D) are switching open and closed at the appropriate times.**

1. (**All series programmers**) If this option is enabled (Switch 6 is up), the running interlock circuit (terminals 3 - P) must be open at the start of each operating cycle (terminals L1 - 13 closing). If the 3 - P circuit is closed at the start of a new operating cycle, the control will "hold" for 1 minute, waiting for this circuit to open. If, within 1 minute, the circuit 3 - P does not open, the control will lockout. If circuit 3 - P is proven open, the control will start its cycle: The blower motor will energize (terminal M) and the control will wait 10 seconds for circuit 3 - P to be proven closed. If not proven closed within 10 seconds, a lockout will occur.
2. (**EP100 series programmers only**). If this option is enabled (Switch 6 is up), terminals D - 8 (high fire purge) and terminals M - D (low fire start) interlocks, are also monitored for open and closed during the programming sequence. If these circuits are proven "closed" at inappropriate periods during the prepurge and light-off sequence, the control will "hold" for 10 seconds, then lockout.



**Fig. 60** Wiring schematic for EP100 and 200 series programmer.

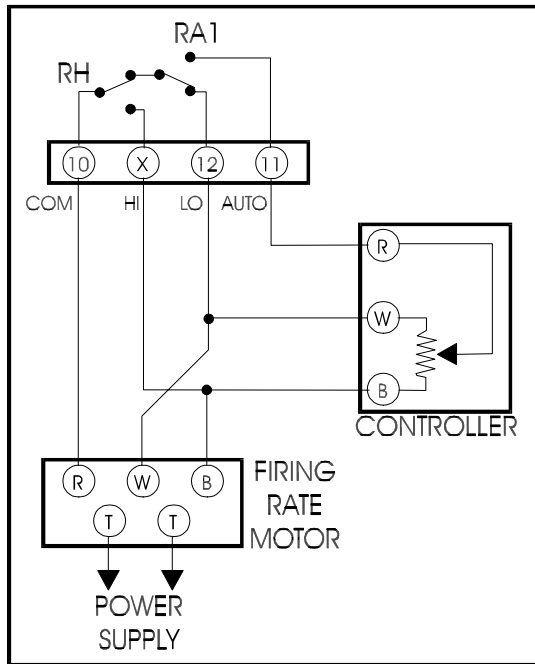


**Fig. 61** Wiring schematic for EP300 series programmer.

**WIRING**

Figures 60 and 61 show generic wiring schematics for flame monitor. Needless to say, each application has its peculiarity and style. But these diagrams, in conjunction with the flame monitor “control sequence diagram”, give a clear indication of the function of each terminal at specific periods in the control sequence. Use these schematics in conjunction with the equipment’s wiring diagram.

**FIRING RATE MOTOR CIRCUIT**



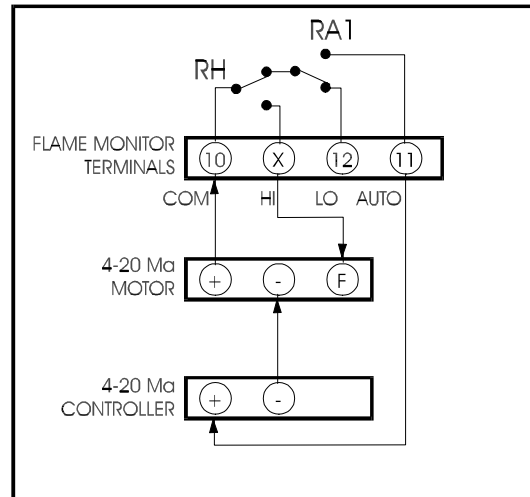
**Fig. 62** Firing rate motor switching wiring when using “Slide wire Potentiometer”

EP100 and 200 series programmers utilize terminals 10, 11, 12 and X to control the firing rate motor during the pre-purge and light-off period:

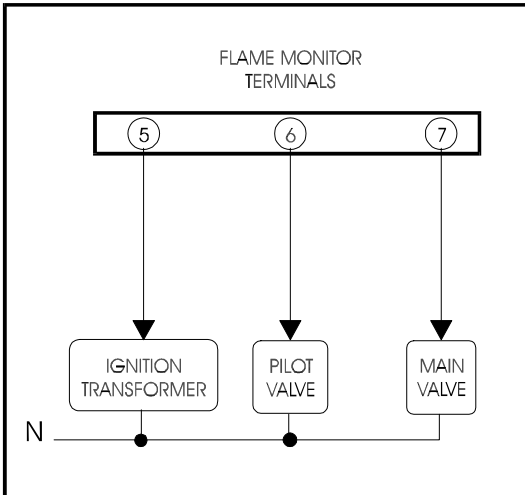
- The control needs to drive the motor to the high fire position and maintain it there during the pre-purge period. (Relay RH; Terminals 10 - X)
- The control drives the firing rate motor to the low fire position and maintains it there for both PTFI and MTFI. (Relay RH, Terminals 10 - 12)
- The control releases the motor to the modulating controller upon completion of successfully establishing main flame and the withdrawal of the pilot flame. (Relay RA1, Terminals 10 - 11)

Figure 62 shows the wiring for a proportioning controller with slide wire (135 ohm) potentiometer system. A potentiometer, or variable resistor, consists of a fine wire wound around a core (term. W – B). A wiper rests on this assembly and moves along the windings. The wiper is connected to terminal R. As the wiper moves back and forth (as determined mechanically by the process demand), the resistance between R and W, and between R and B changes. If the wiper moves toward W, the resistance between R and B increases, and the reverse is true, in that if the wiper moves toward B, the resistance between R and W increases. The modulating motor has a similar feed back potentiometer, which works in conjunction with a balancing relay. The unequal currents flowing through each side of the balancing relay will cause the relay to pivot , engaging the appropriate motor windings. Increasing resistance in the B wire of the motor circuit will cause the motor to drive to the low, or closed position. Increasing the resistance to the W wire of the motor circuit will cause the motor to drive to the high or open position. As is clear from figure 62, resistance between R and B, or R and W are manipulated by the Flame Monitor’s firing rate motor switching circuit, causing the desired effect during the control sequence.

Figure 63 shows the wiring when using a 4 – 20 mA control system

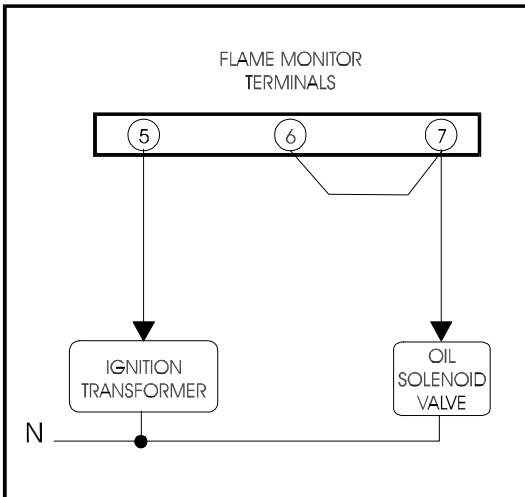


**Fig. 63** Firing rate motor switching wiring when using 4 – 20 mA damper motor.



**Fig. 64** Wiring arrangement for “spark cut-off” feature, EP170 programmer only.

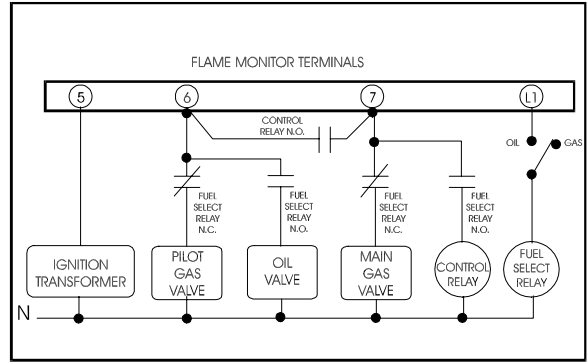
When using an EP100 series programmer and the ignition spark needs to be terminated prior to main trial for ignition, use an EP170 module and wire as shown in figure 64



**Fig. 65** Wiring arrangement for spark ignited oil burner.

Direct light-off oil burners may be wired as per figure 65.

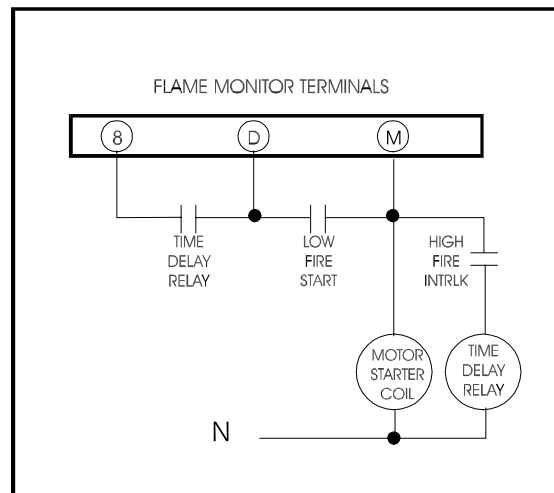
This arrangement may cause the control to lockout on the first light-off attempt and show the message “Fuel valve state change”. This is because the control does not expect voltage at terminal 7 during PTFI. Resetting the control will cause it to accept it. When the jumper between 6 and 7 is removed, it will again lockout displaying this message, requiring a reset to accept and continue.



**Fig. 66** Combination fuel burner wiring with relay for jumpering terminals 6 – 7

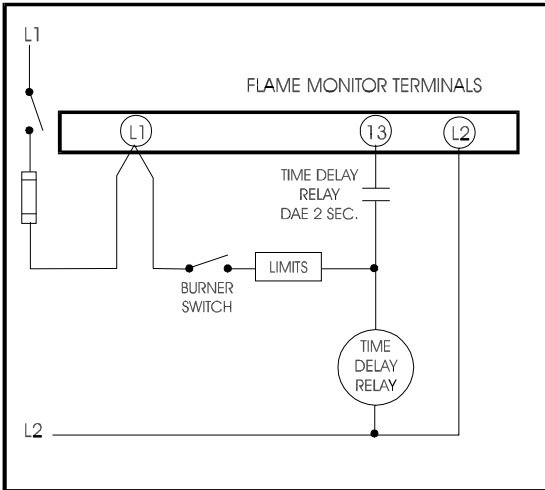
When changing fuels on combination burners where “Direct Spark” is used on oil, it is normal to jumper terminals 6 – 7. To assure that burner operation is not interrupted immediately following the change-over as described above (see figure 65), one of two things must be done:

1. Interrupt power to L1/L2 momentarily when changing fuels, just before the initial cycle on the new fuel.
2. Install a relay contact between terminals 6 and 7, with the relay energized by terminal 7. This will jumper 6 to 7 only after PTFI is complete and will be accepted by programmer.



**Fig. 67** Extending the prepurge for EPD programmer modules.

With EPD programmers there are no dipswitch selectable pre-purge timings. Pre-purge is limited to 30 seconds. Figure 67 shows how pre-purge may be extended using a timer. Maximum time delay setting should not exceed 10 minutes (see page 51).



**Fig. 68** Suggested wiring for power switch-over systems

**SUPPLY VOLTAGE TOLERANCE**

The Fireye Flame Monitor is designed for an input voltage of 120vac – 50/60Hz, with tolerance of + 10% and -15%

At a voltage drop to approximately 85vac the control will shut down and perform an internal reset. Restoration of input voltage to within the specified parameters will render the Flame Monitor operational again.

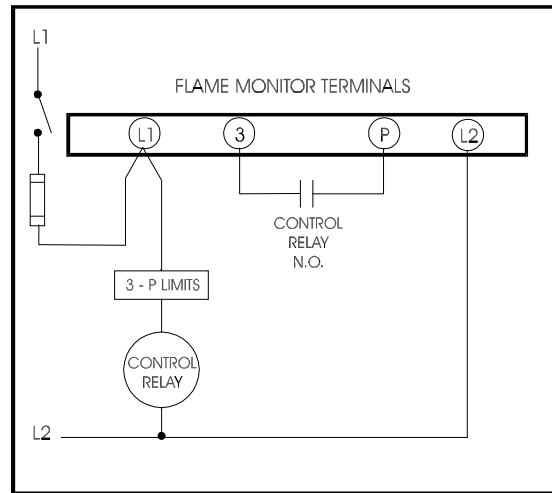
Sometimes a power brownout, or a switchover to a UPS systems may cause problems to the input voltage. Brown outs cause voltage drops and switchovers may cause very short (Microsecond) power interruptions to the control’s input voltage. Both of these may at times actually go unnoticed by the Flame Safeguard control, but their effect may be just enough to cause the fuel valves to close. When this happens, the FSG control will interpret it as a flame failure, not a power problem. In applications where this occurrence may be suspected, figure 68 shows a way to help alleviate this problem. The assumption is (and the time delay relay should be selected as such) that the relay coil would trip along with the fuel valves. Setting the DAE (Delay After Energize) at about two seconds will assure the control will recycle after any brownout or switch-over event, not lockout.

**RUNNING INTERLOCK CIRCUIT 3 - P**

On this note, it is important to remember that circuit 3 to P, the running interlock circuit, carries the complete electrical load of whatever is connected to terminals 5, 6 and 7

It is therefore important to take into account that each device, the sum of all devices and the length of wiring runs in the running interlock circuit 3 – P, needs to be taken into account when designing and trouble shooting the system. The same phenomenon as described above in supply voltage tolerance, applies to this circuit as well. A weak device or excessive wire runs in 3 – P may be the cause of voltage drops or micro-power interruptions, not noticed by the Flame Monitor but causing the fuel valve(s) to close, simulating a flame failure.

In extreme cases it may be required to look into isolating the running interlock circuit via the use of a control relay such as shown in figure 68A below.



**Fig. 68A** Control relay in running interlock circuit.



The following are extensive and very helpful tips for wiring issues with regard to Flame Monitor applications. They are contained in "Service Note #100" provided and released by Fireye in 1998.

For clarity, the entire service note is included below. Copies of this excellent service note can be obtained at your Fireye distributor, or at Fireye's web page; [www.fireye.com](http://www.fireye.com)

## **GROUNDING METHODS FOR FIREYE® FLAME-MONITOR™ APPLICATIONS SERVICE NOTE #100**

### **Definition**

The primary function of electrical grounding required by the National Electrical Code (NEC) is to provide safety for equipment and personnel from abnormal electrical conditions.

The grounding also provides a path for dissipation of the high-energy electrical discharges caused by lightning, as well as prevents build-up of static charges on equipment and materials. In addition, the ground establishes an equipotential or zero-voltage (reference) for the electrical system.

A good ground system should be provided to minimize the effects of AC quality problems. A properly designed ground system meeting all the safety requirements will ensure that any AC voltage quality problems, such as spikes, surges and impulses have a low impedance path to ground. A low impedance path to ground is required to ensure that large currents involved with any surge voltages will follow the desired path in preference to alternative paths, where extensive damage may occur to equipment.

### **General Rules**

The Flame-Monitor system, being microprocessor based, requires a ground system that provides a zero-voltage reference.

Fireye bulletin E1101 specifies, with the Flame-Monitor removed, the voltage measured from L2 to all other terminals except L1 should be 0 volts.

1. The most effective ground is to run the ground wire in the same raceway as the hot and neutral from the main distribution service panel (not intermediate subpanels) to the burner control panel and insure that this ground wire is well bonded to the control panel.

2. The wiring base of the Flame-Monitor must have earth ground providing a connection between the sub-base and the control panel or the burner.
3. The earth ground wire must be capable of conducting the current to blow the 20A fuse in event of an internal short circuit. A number 14 copper conductor is adequate, wide straps or brackets are preferred rather than lead wires.
4. The ground path needs to be low impedance (less than 1 ohm) to the equipment frame, which in turn needs a low impedance to earth ground. For a ground path to be low impedance at RF frequencies, the connection must be made with minimum length conductors having maximum surface areas.
5. All connections should be free of non-conducting coatings and protected against rust.
6. Utilizing conduit as a means of providing a ground must be avoided.
7. Installing ground rods at the burner control panel defeats the purpose of a single point ground as described above and could also present a safety hazard.

### **Upgrade or Retrofit**

It is recommended to change the existing P-Series chassis to a new Flame-Monitor subbase (60-1386-2 or 60-1466-2),

If the installation is an upgrade, particularly using a P-FM adapter, this means the wiring has been in place for a number of years and probably, over time, has had other wires added to the system. All wiring and terminal connections should be inspected for tightness. Long wires should be shortened and routed directly point to point instead of lengthened using wire nuts. If the existing frame is used, the frame of the P-Series chassis should be well bonded to the panel and the adapter securely screwed into the chassis. Often, C-Series and/or D-Series subbases are not properly grounded so the same rules for the P-Series should apply. The subbases for the C and D Series were factory painted and not plated. Good bonding screws with star washers should be utilized. Refer to General Rules above.

### **Installation**

Does not run high voltage ignition transformer wires in the same conduit that contain flame detection wiring. Do not run scanner wires in a conduit with line voltage circuits.





Ensure the frame of the ignition transformer is securely connected to control panel frame or the burner frame.

The Flame-Monitor chassis (E100/E110) contains a transient-suppressing device connected internally across hot and neutral and then to the internal bracket. For this to be effective the chassis must be screwed securely into the wiring subbase so that the spot face on the bracket located in the E100/E110 chassis comes in contact with the locking nut located in the subbase.

### **Remote Display**

When the ED510 is to be remotely mounted on the front of the control panel, the ED580 cable must contain a ferrite core, currently supplied by Fireye with the ED580 cable. High frequency currents flow more to the surface of the conductor. The 60 Hz ground system, properly designed, has sufficient low-impedance at 60 Hz to maintain all metal surfaces at the same ground reference. But, this same system is unable to provide this at higher frequencies because of the increased impedance caused by the 'skin effect'. The purpose of the ferrite core is to provide a low-impedance at these higher frequencies and absorb this unwanted energy. Care must be taken not to route the ED580 cable in close proximity to any starter motor contactor located in the control panel or across any high voltage ignition wires. Refer to Fireye bulletin E-8002 for proper installation.

### **Communications**

When interfacing Fireye controls to a communication system, be it an E500, PLC or other microprocessor based device, ferrite cores should also be utilized. Fireye supplied ED512 cables provide the ferrite cores attached to the cables. For longer runs beyond the lengths of ED512, proper twisted shielded pair cable must be utilized. In a multi-drop system, the shields should be tied together within a cabinet and not to any ground point. The shield at the source end of the cable of the multi-drop connection can then be terminated to ground. Source end is defined as the originating end of the communication system. Care must be taken not to route communication cables in close proximity to any starter motor contactor located in the control panel or across any high voltage ignition wires.

Refer to Fireye bulletin E-8002 for proper installation.

### **Expansion Module**

For connection to an E300 expansion module, the Fireye E350 cable must be utilized with the green grounding wire being connected to the green screw at the Flame-Monitor end. Care must be taken not to route the expansion module cable in close proximity to any starter motor contactor located in the control panel or across any high voltage ignition wires. It is not good practice to route the E350 cable in the same race way as the high voltage control wires.

### **Scanners**

The armored cable supplied with the Ultra-Violet and Infrared scanners should be connected to equipment by means of a good mechanical connection such as a conduit fitting. It may be necessary to utilize heat insulator (35-69) to isolate the sensing end of the scanner from boiler ground. Care must be taken not to route the scanner cable across the high voltage ignition cable. The high-energy ignition cable should be checked periodically for cracking, connections and aging.

In applications using flame rod units and the ERT1 amplifier, it may be beneficial to route a separate return wire for the S2 terminal to the flame rod assembly. This will minimize the effects of transient currents flowing into the Flame-Monitor.

In all cases, scanner wires should be routed in separate conduit and not joined with any high voltage AC or ignition cables.

### **Maintenance**

Periodically, the spark electrode should be inspected for proper gapping and cracked ceramics. At ignition time, the high energy from the ignition transformer will attempt to conduct to the point of least resistance and with an improper spark gap, where the conduction takes place will no longer be controlled. The VA rating of the control transformer must be sized to handle the inrush currents of the pilot solenoid and ignition transformer at PTFI and then the inrush currents of the main fuel valve assembly at MTFI time. Inspect neatness of wiring in junction boxes and cabinets. It is best to have connections short and direct and also not having wires bunched up and tied off. Also connections should be periodically inspected for tightness and corrosion.

## DISPLAY MODULE



**Fig. 69** Flame Monitor Display Module, part no. ED510 with connector cable part no. ED580-1

A key feature of the Flame Monitor system is its diagnostics capabilities. Current operating status and safety lockout information are displayed on the alphanumeric display module, part no. ED510, shown in figure 69.

The display module is designed to operate with the EP and EPD style programmer modules, as well as the Micro-M control series. (Operation with EPD style modules requires remote mount). The display module provides the following features and capabilities:

- Two line, each 16 character, LCD backlit display.
- Continuous display of current burner operating status, including burner, safety lockout information.
- Three key, tactile dome keypad allowing access to display functions, such as last six lockout conditions complete with burner cycle and burner hour time stamp
- Mounts directly onto the front face of EP style programmer modules.
- Module connects to EP, EPD style modules, or Micro M control, via standard RJ style connector (see figure 69).

- Designed for use with EP style programmer modules, but can be used with EPD style programmer, or Micro M control, when using remote mount kit utilizing standard DIN sized panel door opening (92 mm X 92mm).
- The display module can mounted 8 feet away from the control when using ED580-(length) cable, or hundreds of feet away when using belden cable plus the ED610 adapter board. When mounting the display module not within sight and sound of the burner, it may be desirable, and required, to disable the Reset function. A jumper located on the ED610 adapter board, disables the reset function when moved from position 1-2 to position 2-3 (see bulletin E-8002).



**Fig. 70** ED510 display module mounted on programmer, complete with ED580-1 cable



**KEYPAD**

There are three tactile pads to choose from located on the front of the display module:

**SCRL** (Scroll), **RESET** and **MODE**

**SCRL**

- Used to advance through and display operational information associated with the control, including various **sub-menus**. Treat it like a “NEXT” key. Where ever you are in a menu, pressing this key will “scroll” you to the next item.

**RESET**

- Press to reset the control after a lockout condition has occurred. The control will reset, and if conditions allow, the next operating cycle will start. Sub-menus also make use of this key for things like unit (Communication) address, and customized messages.

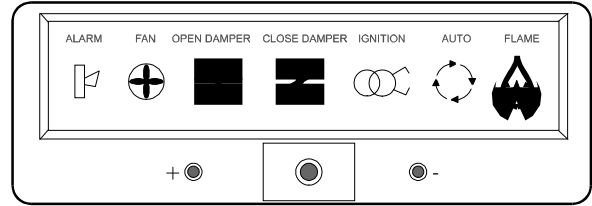
**MODE**

- Use this key to change mode, from standard menu to a sub-menu. Any time a small right pointing arrow appears at the end of a menu item i.e. “LOCKOUT HISTORY”, you can press the MODE key to enter this sub-menu, or to exit back to the standard menu.

**EPD STYLE PROGRAMMER MODULES**



**Fig. 71** EPD style programmer module



**Fig.72** EPD programmer module LED indicator lights. Shown here with description added above each.

EPD style programmers are provided with a series of seven LED indicator lights to annunciate the current operating status. Figure 72 shows the symbols of each LED with a description above.

- Alarm:** lights when unit is in lockout
- Fan:** Lights when blower motor is energized.
- Open Damper:** Blinks when damper is driven to high purge position, lights constant when high purge limit is made (Term. D – 8).
- Close Damper:** Blinks when damper is driven to low fire position, lights constant when high purge limit is made (Term. M - D).
- Ignition:** Blinks during PTFI, Lights constant during MTFI
- Auto:** Lights when MTFI complete and control releases to automatic (Terminals 10 – 11 made), blinks when RUN/CHECK switch is in Check mode during Run period.
- Flame:** Lights whenever flame is detected.

While the burner is off (L1 – 13 open), the LED’s blink every 60 seconds to indicate the “off” condition. Pressing the Reset button also causes the LED’s to blink in succession.

The LED’s also are used to provide information on the reason for the last lockout. The reset button must be pressed twice to reset any lockout. During any lockout, pressing the reset button once will cause the LED’s to light up according to a code, indicating the reason for the lockout condition. These codes are available in the technical bulletin provided with each programmer.

The ED510 display module can be used on any EPD style programmer, either mounted remote, for permanent use or hand held for service use only.



**FLAME MONITOR MESSAGES**

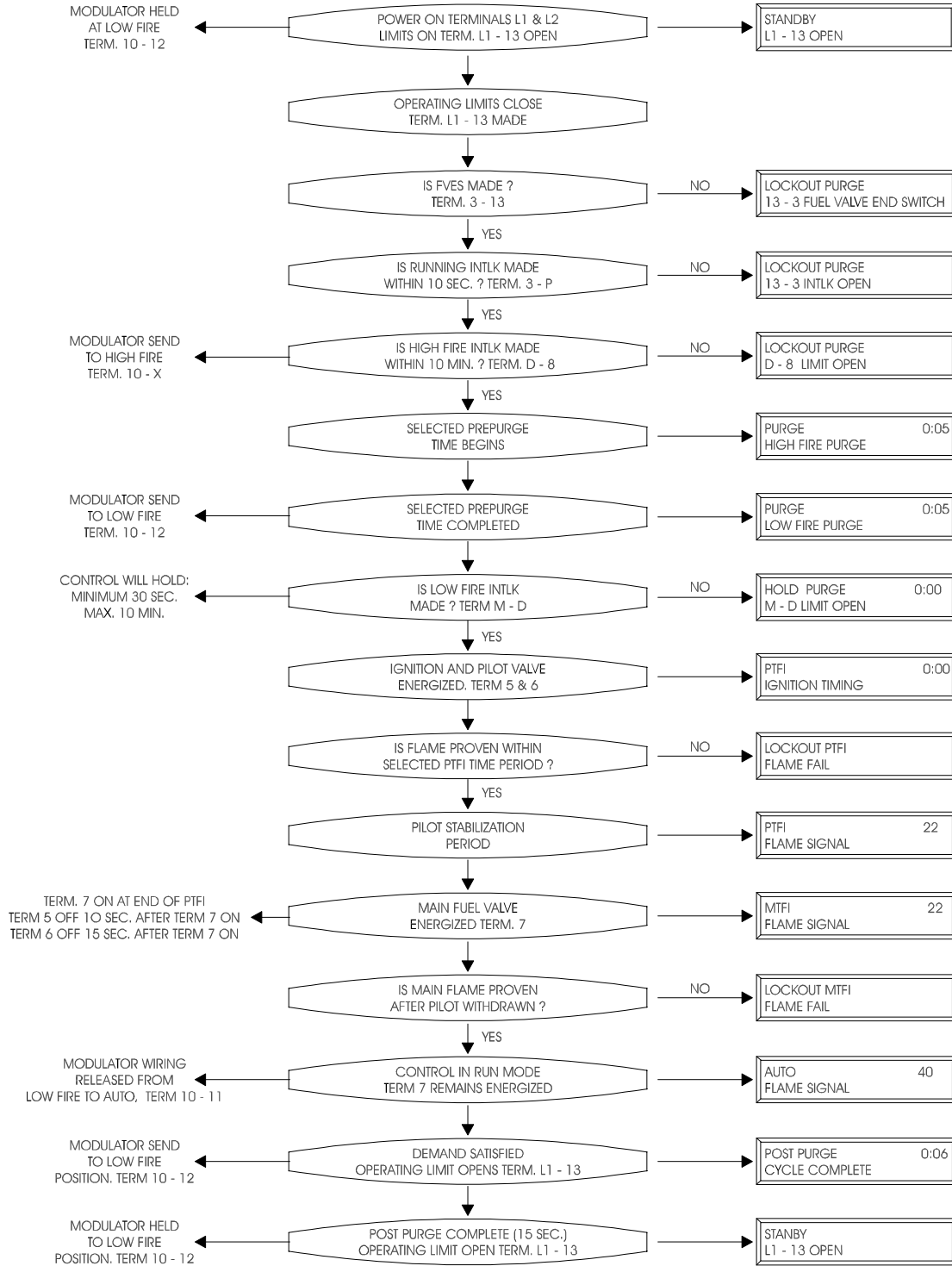
As previously mentioned, a key feature of the Flame Monitor is its diagnostic capabilities. Below is a listing of all known and available messages at the time of writing. These have been arranged in alphabetic order for ease of locating each.

<u>MESSAGE</u>	<u>DESCRIPTION</u>
3 - P LOW GAS PRESSURE	This is an E300 message and refers to a limit in circuit 3 - P
3 - P LOW OIL PRESSURE	This is an E300 message and refers to a limit in circuit 3 - P
3 - P LOW OIL TEMPERATURE	This is an E300 message and refers to a limit in circuit 3 - P
3 - P LOW WATER	This is an E300 message and refers to a limit in circuit 3 - P
13 - 3 FUEL VALVE END SWITCH	The POC switch wired between terminals 3 - 13 opened before MTFI
3 - P AIR FLOW OPEN	This is an E300 message and refers to a limit in circuit 3 - P
3 - P ATOMIZING MEDIA	This is an E300 message and refers to a limit in circuit 3 - P
3 - P AUX #4 OPEN	This is an E300 message and refers to a limit in circuit 3 - P
3 - P AUX #5 OPEN	This is an E300 message and refers to a limit in circuit 3 - P
3 - P AUX #6 OPEN	This is an E300 message and refers to a limit in circuit 3 - P
3 - P HIGH GAS PRESSURE	This is an E300 message and refers to a limit in circuit 3 - P
3 - P HIGH PRESSURE	This is an E300 message and refers to a limit in circuit 3 - P
3 - P HIGH TEMPERATURE	This is an E300 message and refers to a limit in circuit 3 - P
3 - P HIGH WATER	This is an E300 message and refers to a limit in circuit 3 - P
3 - P INTLK OPEN	Circuit 3 - P has failed to close within first 10 seconds of purge. Or has opened during operating cycle.
3 - P NO FUEL SELECTED	This is an E300 message and refers to a limit in circuit 3 - P
3 - P INTLK CLOSED	Dipswitch #6 is enabled. Check for 3-P circuit open on start has not passed. Unit will hold for 60 second for 3 - P to open followed by lockout. (Se page 51)
AC POWER FAIL	Power interruption caused the control to lockout. EP165 and 166 only.
AIR FLOW OPEN	This is a message selected from the E300 message menu and refers to a limit in either circuit L1 - 13, or 3 - P
AUTO CHECK AMPLIFIER FAIL	Amplifier module failure. Replace amplifier module
BLOWER MOTOR INTLK	This is a message selected from the E300 message menu and refers to a limit in either circuit L1 - 13, or 3 - P
BNR CYCLES	Number of hours operating control (L1 - 13) has been closed
BNR HOURS	Number of hours terminal 7 has been energized
BNR LOCKOUTS	Number of control safety lockouts

CHECK AMPLIFIER	: High electrical noise. Check phase on L1/L2 is the same as on the control's interlock circuits. Defective amplifier ? Defective IR scanner cell ? See page 56
CHECK CHASSIS	: Voltage on terminal 7 at improper time? Defective Chassis ? Defective programmer ?
CHECK EXPANSION MODULE	: Expansion module part no. E300 failed. Replace E300
CHECK PROGRAMMER	: Voltage on terminals 5, 6 at improper time ? Defective Chassis ? Defective programmer ?
CHECK SCANNER	: UV scanner "Self-Check" failure. Defective UV tube ? Defective shutter assembly ? Electrical noise on scanner wiring ?
COMBUSTION AIR END SWITCH OPEN	: This is a message selected from the E300 message menu and refers to a limit in either circuit L1 - 13, or 3 - P
CONTROL PANEL SWITCH OPEN	: This is a message selected from the E300 message menu and refers to a limit in either circuit L1 - 13, or 3 - P
CYCLE COMPLETE	: Operator open (L1 - 13) unit in post purge
D - 8 HIGH LIMIT	: Run-Check switch placed in Check, modulator driven to high position.
D - 8 LIMIT CLOSED	: Dipswitch #6 is enabled. Check for D - 8 circuit open on start has not passed. Unit will hold for 30 second for D - 8 to open followed by lockout. (Se page 51)
D - 8 LIMIT OPEN	: Waiting for terminals D - 8 to close. Maximum wait is 10 minutes followed by lockout.
DAMPER POSITION END SWITCH OPEN	: This is a message selected from the E300 message menu and refers to a limit in either circuit L1 - 13, or 3 - P
E300 MSG SELECT	: From here press MODE key to access the pre-programmed lockout messages stored in memory, associated with the E300 expansion module.
E340 OP CNTL OPEN	: This is a message selected from the E300 message menu and refers to a limit in either circuit L1 - 13, or 3 - P
E340 SAFETY INTLK OPEN	: This is a message selected from the E300 message menu and refers to a limit in either circuit L1 - 13, or 3 - P
F.D. FAN INTLK	: This is a message selected from the E300 message menu and refers to a limit in either circuit L1 - 13, or 3 - P
FALSE FLAME	: Flame has been detected at an inappropriate time
FLAME FAIL	: Control did not have, or lost flame signal
FLAME SIGNAL	: Flame proven, signal strength shown in upper right hand corner 0 - 9 Not acceptable 10 Minimum acceptable 20 - 80 Normal
FUEL VALVE STATE CHANGE	: During PTFI, the voltage sensed has changed from the previous cycle. See page 54, figures 65 and 66
HIGH FIRE PURGE	: Modulator motor send high (10 - X made)
HIGH GAS PRESSURE	: This is a message selected from the E300 message menu and refers to a limit in either circuit L1 - 13, or 3 - P

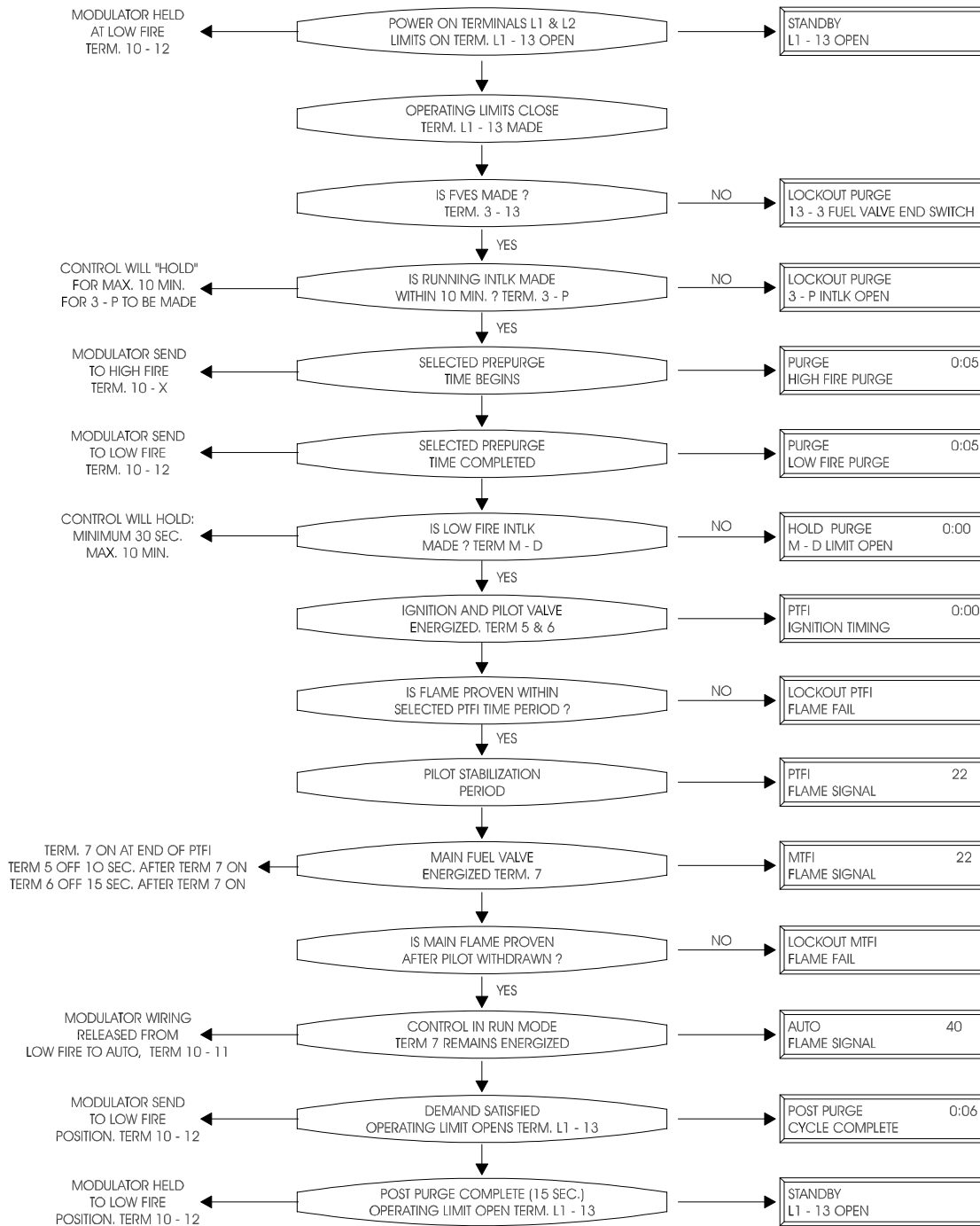


- HIGH OIL PRESSURE : This is a message selected from the E300 message menu and refers to a limit in either circuit L1 - 13, or 3 - P
- HIGH OIL : This is a message selected from the E300 message menu and refers to a limit in either circuit L1 - 13, or 3 - P
- TEMPERATURE
- HIGH PRESSURE : This is a message selected from the E300 message menu and refers to a limit in either circuit L1 - 13, or 3 - P
- HIGH STACK : This is a message selected from the E300 message menu and refers to a limit in either circuit L1 - 13, or 3 - P
- TEMPERATURE
- HIGH : This is a message selected from the E300 message menu and refers to a limit in either circuit L1 - 13, or 3 - P
- TEMPERATURE
- HIGH WATER : This is a message selected from the E300 message menu and refers to a limit in either circuit L1 - 13, or 3 - P
- I.D. FAN INTLK : This is a message selected from the E300 message menu and refers to a limit in either circuit L1 - 13, or 3 - P
- IGNITION TIMING : PTFI Started Flame not yet proven
- L1 - 13 AUX. #1 : This is an E300 message and refers to a limit in circuit L1 - 13
- OPEN
- L1 - 13 AUX. #2 : This is an E300 message and refers to a limit in circuit L1 - 13
- OPEN
- L1 - 13 AUX. #3 : This is an E300 message and refers to a limit in circuit L1 - 13
- OPEN
- L1 - 13 OPEN : Operating control open (L1 - 13)
- LINE FREQUENCY : Electrical noise detected on L1 and L2.
- NOISE DETECTED : Refer to page 56
- LOCKOUT HISTORY : From here press MODE key to access information on the last 6 lockouts stored in memory.
- LOW ATOMIZING : This is a message selected from the E300 message menu and refers to a limit in either circuit L1 - 13, or 3 - P
- PRESSURE
- LOW FIRE PURGE : Modulator motor send low (10 - 12 made)
- LOW FIRE SIGNAL : Run-Check switch placed in Check, modulator driven to low position. Flame signal strength is displayed
- LOW GAS : This is a message selected from the E300 message menu and refers to a limit in either circuit L1 - 13, or 3 - P
- PRESSURE
- LOW OIL PRESSURE : This is a message selected from the E300 message menu and refers to a limit in either circuit L1 - 13, or 3 - P
- LOW OIL : This is a message selected from the E300 message menu and refers to a limit in either circuit L1 - 13, or 3 - P
- TEMPERATURE
- LOW WATER : This is a message selected from the E300 message menu and refers to a limit in either circuit L1 - 13, or 3 - P
- LOW WATER : This is a message selected from the E300 message menu and refers to a limit in either circuit L1 - 13, or 3 - P
- M - D LIMIT CLOSED : Dipswitch #6 is enabled. Check for M - D circuit open on start has not passed. Unit will hold for 30 second for M - D to open followed by lockout. (Se page 51)
- M - D LIMIT OPEN : Waiting for terminals M - D to close. Maximum wait is 10 minutes followed by lockout.
- M - D LOW LIMIT : Run-Check switch placed in Check, modulator driven to low position.
- OIL GUN END : This is a message selected from the E300 message menu and refers to a limit in either circuit L1 - 13, or 3 - P
- SWITCH OPEN
- PROGRAM SETUP : From here press MODE key to display details on operating parameters of programmer and amplifier module.
- SCANNER NOISE : Electrical noise on scanner wiring. See page 57 "Scanners"
- SHORT CIRCUIT : Short circuit, or excessive current detected on terminals 5, 6 or 7. See page 40 "Before installing the control"
- TERM 5,6,7
- SYS HOURS : Number of hours the control has been powered (L1 / L2)
- SYSTEM ERROR : Programmer module failure. Replace programmer module
- SYSTEM INFO : From here press MODE key to display details on operating parameters of the control.
- UNIT ADDRESS : Run-Check switch placed in Check, L1 - 13 (operating control is open), press reset button here for one second intervals to increase unit address
- WAITING FOR DATA : Communication between control and display module is disrupted and needs time to correct. Plugging in the ED510 display while control is powered may cause this. Running ED580 cable with other power wiring also causes this. See page 57 "Remote display" Removing and restoring power while ED510 is connected will recover proper operation.



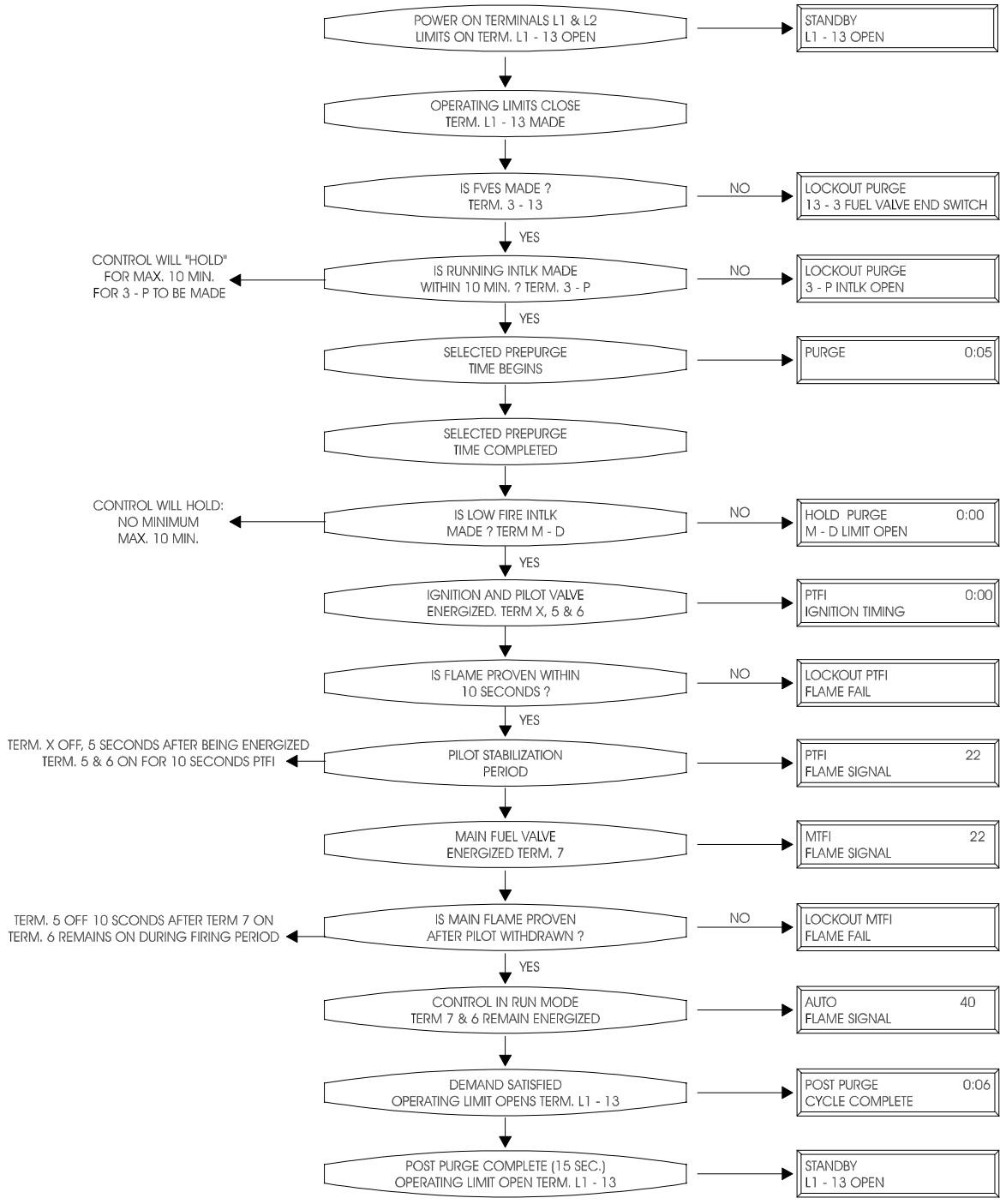
CONTROL LOGIC FLOW DIAGRAM, NORMAL CYCLE.  
FOR EP100 AND EPD100 SERIES PROGRAMMER MODULES

**Fig. 73** Logic flow diagram for EP 100 series programmers



CONTROL LOGIC FLOW DIAGRAM, NORMAL CYCLE.  
FOR EP200 AND EPD200 SERIES PROGRAMMER MODULES

**Fig. 74** Logic flow diagram for EP 200 series programmers



CONTROL LOGIC FLOW DIAGRAM, NORMAL CYCLE.  
FOR EP300 AND EPD300 SERIES PROGRAMMER MODULES

**Fig. 75** Logic flow diagram for EP 300 series programmers





## TROUBLE SHOOTING FLAME MONITOR, E110 CONTROL

### No voltage at term. L1 – L2 (All LED's off on EPD programmer, nothing on display on EP programmer )

- Electrical supply switched off.
- Blown fuse or tripped breaker.
- Bent tab on bottom of control.
- Loose connection.
- Wiring error.

### Improper voltage at term. L1 – L2

- Min. operating voltage 102vac
- Max. operating voltage 132vac

### No voltage at term. 13 (Standby, L1 – 13 Open)

- Burner on/off switch off.
- Operating or limit control open.
- Loose connection.
- Wiring error.
- Check for bad tabs (see Fig. 48)

### No voltage at term. 3 (Lockout Fuel Valve End Switch)

- Fuel valve's "proof of closure" switch open.
- System has no POC switch and no jumper installed at terminals 3 – 13
- Check for bad tabs (see Fig. 48)

### Blower motor does not start.

- Control is in lockout.
- Motor three-phase power off.
- Defective motor or contactor.
- Check for bad tabs (see Fig. 48)
- If no voltage at term. M, replace chassis.

### Control locks out on False Flame

- Flame is detected at inappropriate time.
- Check for actual flame being detected.
- Check for incorrect scanner wiring causing electrical noise, causing false signal. See page 57.
- Defective UV tube giving false flame signal. See page 13
- Defective amplifier module.

### Blower runs, purge is not initiated. (EP200 and 300 series) (Hold Purge 3 - P INTLK Open)

- One of the interlocks wired between term. 3 and P is open.
- Wiring error.
- Check for bad tabs (see Fig. 48)

### Modulator is driven to high, but no further progress in program sequence. (EP100 series) (Hold Purge D – 8 Limit Open).

- High fire purge interlock end-switch not made. Terminals D – 8
- If the application does not use a high fire end switch to prove high purge position, D – 8 should be jumpered when using an EP100 series programmer.

### Modulator driven to low, but no further progress in program sequence. (Hold Purge M - D Limit Open).

- Low fire end-switch not made. Terminals M – D
- If the application does not use a low fire start switch to prove a safe light-off position, M – D should be jumpered regardless of which series programmer.

### PTFI starts, Control locks out. (Fuel Valve State Change \* )

- Control sees that voltage at terminal 7, when terminal 6 is energized, is not the same as with last cycle. See page 54 for more detail.
- Control is reading feed-back on terminals 5, 6, or 7 from PLC or DCS input wiring. Install isolation relays.

### PTFI starts, Control locks out. (Short Circuit Term. 5,6, 7) (Check Chassis)

- Short circuit or excessive current detected at terminal 5, 6 or 7. Do test described on page 40, heading; "Before Installing The Control".
- Wiring error
- Wiring base not grounded
- Control panel not grounded
- Step-down transformer, primary side neutral not grounded
- Ignition transformer not grounded



**Pilot fails to establish, Display reads PTFI for 10 seconds, followed by lockout. No visual presence of flame.**

**(Lockout PTFI Flame Fail)**

- (Pilot) Fuel supply shut off.
- Air in fuel line (needs purging)
- Defective pilot valve.
- Incorrect fuel pressure (check pilot reg.)
- Defective ignition transf. (Check for spark).
- Incorrect spark-gap at igniter assembly.
- Incorrect location of spark electrode tips in relation to pilot burner.
- Incorrect wiring of pilot components.
- Check for correct voltage at term. 5 or 6 during PTFI . If none, check for dirty or bent tab at bottom of control chassis. See figure 48. Also check wiring base tabs.

**Pilot fails to be detected, Display reads PTFI for 10 seconds, followed by lockout. Yet visual presence of flame.**

**(Lockout PTFI Flame Fail)**

- Flame detector not detecting flame.
- Inadequate pilot flame.
- Improper amplifier module installed.
- Flame rod not making contact with flame.
- Defective flame rod. (porcelain)
- Grounding surface of pilot assembly (Flame Rod) too small (corroded). Replace pilot burner. See page 8
- Incorrect detector wiring. See page 57
- (Flame rod system). No ground-path from pilot burner to FSG control. Provide ground wire from control chassis, terminal S2, to pilot assembly.
- Flame detector dirty.
- Incorrect line of sight for flame detector.
- Unstable pilot flame.
- Incompatible flame detector for fuel used.
- Defective flame detector or amplifier module.

**It takes seconds before the pilot flame is detected after terminal 5 and 6 are energized.**

- Unstable pilot flame.
- Incorrect location of spark electrode tips in relation to pilot burner.
- Defective, weak, ignition transformer.
- No ground-path, ignition transformer-to-burner-front.
- Incorrect (too high) fuel pressure.
- Incorrect primary air adjustment on pilot burner.

- Bad pilot burner assembly. Pilot should remain stable when spark ignition is turned off.

**Main flame fails to establish after PTFI (Lockout MTFI Flame Fail)**

- Main, manual shut off valve closed.
- Defective main ESD fuel valve.
- Wiring error to main fuel valve.
- Improper fuel pressure(s).
- Oil not atomized properly.
- Oil nozzle (plugged) troubles.
- Main valve opening causes fuel pressure limits (high or low) to trip.
- Main valve opening causing pilot to bow out.
- Main burner needs pilot burner. Goes out when pilot interrupted. Needs air, fuel, or air-fuel ratio adjustment at light-off position.
- Furnace pressure incorrect.
- Scanner detects pilot flame, but does not detect main flame.

**Flame Signal diminishes with time after main burner lights.**

- Main burner burns off-ratio.
- Main burner improperly adjusted.
- Infrared detector saturates. (see page 16)
- Flame reduces flame flicker as flame temperatures increase (Applies to infrared detection only).
- Bad cell in infrared detector.
- Bad UV tube in ultraviolet flame detector.
- Steam atomization blocks flame signal. (UV detector on steam atomized oil burner). Reposition detector for more angular view if possible.
- Pilot burner “pulled away” from flame rod by main burner firing. (Flame rod systems on natural draft burners).
- Excessive scanner temperatures. Provide cooling air to scanner.
- Electrical noise on scanner wiring.

**Burner locks out on Flame Failure during main flame firing.**

**(Lockout Auto Flame Fail)**

- Main burns off-ratio. Main fuel pressure too high.
- Main burner improperly adjusted.
- Infrared detector saturates. (see page 16)
- Bad UV tube in ultraviolet flame detector.
- Steam atomization blocks flame signal. (UV detector on steam atomized oil burner).



Reposition detector for more angular view if possible.

- Pilot burner “pulled away” from flame rod by main burner firing. (Flame rod systems on natural draft burners).
- Power spike, unnoticed by FSG but closing fuel solenoid valves. See page 55.
- Operating, or running interlock limit “weak” causing short drop in voltage, unnoticed by FSG but closing fuel solenoid valves. Note that each device and the sum of all devices need to carry the electrical load capacity of terminals 5, 6 and 7. See page 55.
- Insufficient grounding to control wiring base.
- Flame detector wiring in common conduit. Should be in separate conduit.
- Interference by x-rays or extreme sources of electrical noise.
- Defective main safety shutoff valve.
- Defective main gas regulator.