



SF-1  
December 15, 2020

# **FIREYE®**

## **SureFire™**

# **HIGH ENERGY SPARK IGNITER**

## **(HESI)**

### **Instruction Manual**

---

## **DESCRIPTION**

The High Energy Spark Igniter (HESI) is a Class 3 (special) igniter used for direct spark ignition of oil or gas igniters or small burners. The 12 joules of power delivered to the spark tip easily ignites the fuel. Three sparks per second are delivered. The High Energy Spark Igniter consists of three major components: a power pack, a spark rod, and a cable.

The power pack is packaged in a NEMA-4 or NEMA-4X enclosure suitable for wall mounting at the burner front. The power pack develops the 12 joules of power delivered to the spark tip through the use of heavy-duty electrical components. It has a 100% duty cycle at temperatures up to 130° F ambient.

The spark rod features a self-cleaning surface gap spark tip that is easily replaceable through a threaded connection. Spark rods are available with an optional retraction assembly to allow the spark tip to be inserted and retracted from the firing position.

---

## **FEATURES**

### **Non-fouling Spark Tip**

The surface gap spark tip produces a self-cleaning, highly reliable, 12-joule spark even in the presence of moisture, oil, and carbon deposits.

### **Removable Spark Tip**

The spark tip completely detaches from the spark rod through a threaded connection. Replacement of the spark tip is quick and easy.

### **Safe Operation**

Heavy-duty, UL-approved flexible cable connects the power unit to the spark rod assembly ensuring operator safety.

### **Application Flexibly**

Standard and retractable HESI models are available to fit a variety of igniter or burner types.



## Table of Contents

DESCRIPTION .....	1
FEATURES .....	1
SPECIFICATIONS.....	3
OVERVIEW .....	3
SAFETY .....	7
INSTALLATION .....	7
COMMISSIONING.....	9
OPERATION.....	10
TROUBLESHOOTING .....	10
MAINTENANCE .....	10
RECOMMENDED SPARE PARTS .....	11
ORDERING INFORMATION: FIXED MOUNT HESI IGNITER.....	12
ORDERING INFORMATION: RETRACTABLE MOUNT HESI IGNITER .....	14



---

## SPECIFICATIONS

<b>Igniter Class:</b>	Class 3 special
<b>Approval:</b>	Factory Mutual
<b>Output Energy:</b>	12 joules per spark
<b>Output Voltage:</b>	2000 vdc
<b>Input Voltage:</b>	110/220 VAC, +/- 10%, 50/60 Hz
<b>Input Power:</b>	110 vac (2-A fuse); 220 vac (1-A fuse)
<b>Spark Rate:</b>	3 sparks per second
<b>Spark Rod Length:</b>	195 in. (495.3 cm) maximum
<b>Spark Rod Diameter:</b>	0.625 in. (1.6 cm)
<b>Spark Tip Type:</b>	Surface gap (aircraft)
<b>Spark Tip Length:</b>	8 and 27 inches (20.3 and 68.6 cm)
<b>Spark Tip Resistance:</b>	200 to 600 ohms (center electrode to outer case)
<b>Spark Tip Material:</b>	Stainless steel with a silicon carbide insulator
<b>Maximum Recommended Tip Temperature:</b>	537.8° C (1000° F)
<b>Power Pack Temperature Ratings:</b>	-18° C to 57° C (0° F to 135° F)
<b>Power Pack Enclosure:</b>	NEMA-4 approved cabinet (NEMA-4X optional)
<b>Power Pack Dimensions:</b>	10 in. high x 8 in. wide x 4.25 in. deep (25.4 cm x 20.3 cm x 10.8 cm)
<b>Power Pack Mount Holes:</b>	10.75 in. x 6.0 in. (27.3 cm x 15.2 cm)
<b>Field Conduit Hole Diameter:</b>	0.88 in. (2.2 cm)
<b>Power Cable:</b>	12 gage, 3000 v, in 0.5-in. (1.3-cm) flexible conduit
<b>Power Cable Lengths:</b>	6, 9, 12, 15, 20, 25, 50 ft. (1.8, 2.7, 3.7, 4.6, 6.1, 7.6, 15.2m), 15 foot standard
<b>Duty Cycle:</b>	100% at temperature rating

---

## OVERVIEW

1. Mount the power pack in a suitable location as far as possible from the burner front extreme temperatures. Ensure that cable connectors are facing downward.
2. Carefully insert the HESI spark rod tip into the guide tube until the spark rod extends into the primary ignition zone. With Fireeye SureFire 20 gas igniters, position spark tip flush with front of baffle plate.
3. If retraction assembly is supplied, manually or automatically exercise the retract assembly to verify correct operation.
4. Once tip penetration is set, attach and tighten the locking device to the spark rod.
5. Connect cable assembly from the power unit to the spark rod. Tighten threaded connection.
6. Connect power input leads to H (hot), N (neutral), and G (ground) to terminal block 2 inside the power pack.
7. Energize the power pack to test the spark tip. Observe proper operation.



## HESI SPARK ROD

The HESI spark rod comes in lengths from 14" (356mm) up to 180" (457 mm) in 2" (51mm) increments. The HESI spark rod features a positioning rod and a removable surface gap spark plug tip designed for long life and ease of maintenance.

**FIGURE 1.** High Energy Spark Rod Assembly

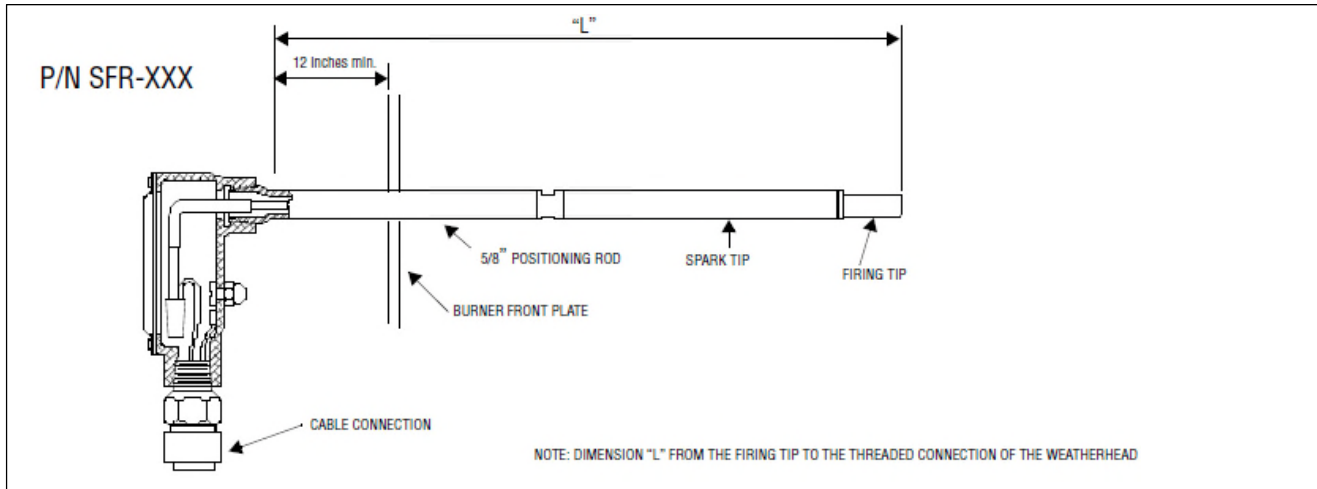

### LENGTH SELECTION

The "L" dimension is the distance from the firing end of the spark tip back to the threaded connection between the positioning rod and the weather head. In selecting a HESI spark rod length there are two dimensions that make up the total rod length. One is the distance from the firing end of the spark tip back to the burner front plate, and the other is the distance from the burner front plate back to the threaded connections at the weather head. The total of these two distances equals the dimension "L" of the HESI spark rod. Both dimensions can be obtained from a burner drawing if it is a retrofit application. If this is a new HESI application the following general rules can be used:

### GAS IGNITERS

Locate the spark tip at the upstream location of the primary combustion zone. Measure the distance back to the burner front plate. Add 12" (305mm) to this distance for the amount of exposure outside the burner front plate. The total of these two distances will be the dimension "L". Refer to the HESI spark rod drawing.

### HESI POWER PACK

The HESI power pack comes in two voltages, 110 VAC and 220 VAC, 50/60HZ, and is housed in a NEMA-4 junction box made of carbon steel painted gray or a NEMA-4X junction box made of brushed stainless steel.

### HESI INTERCONNECTING CABLE

This is a two conductor, prefabricated cable, sheathed in a flexible conduit with plug-in connectors at both ends. The HESI is offered in 6' (1.83), 9' (2.74m), 12' (3.66m) and 15' (4.72m) lengths.

### HESI MOUNT TUBE -Fixed (optional)

The HESI Mounting Tube consists of a 1.05" (27mm) OD, carbon steel, with packing gland, locking collar and quick release coupling. The mount tube is suitable for welding directly onto the burner front plate and it provides support for the HESI rod. Select the mount tube length based upon the HESI igniter length (see Ordering Information section). If the HESI is to be used in conjunction with an oil igniter, please refer to the HESI Retraction Assembly.



### HESI SPARK TIP

The spark tip (provided with spark rod) comes in one of two lengths depending on the length of the spark rod.

PART NUMBER	SPARK TIP LENGTH
145-18	8" (203mm) for spark rods 36" (914mm) and shorter
145-19	27" (686mm) for spark rods 38" (965) and longer

**FIGURE 2.** High Energy Spark Igniter, Fixed Mount

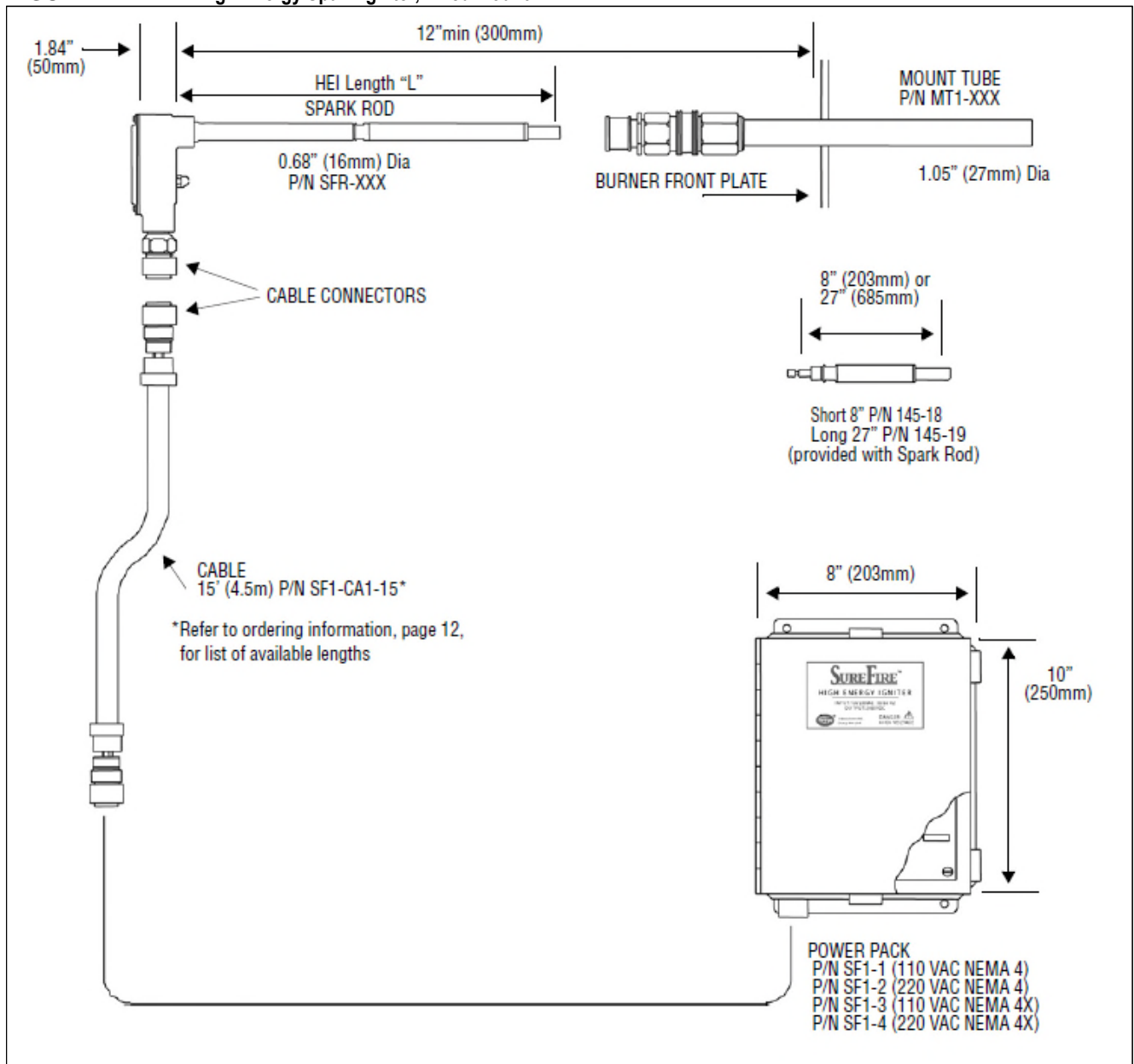



### AUTOMATIC RETRACTION (optional)

For automatic HESI retraction, you must specify the following:

1. HESI Retractor Assembly (consisting of pneumatic cylinder, extended-position limit switch, packing gland and collar).
2. Retraction mount tube (P/N MT1R-XXX).
3. HESI spark rod (SFR-XXX).
4. HESI Power Pack (P/N SF1-X).
5. HESI interconnecting cable (P/N SF1-CA1-XX).

**FIGURE 3. High Energy Spark Igniter, Automatic Retraction**

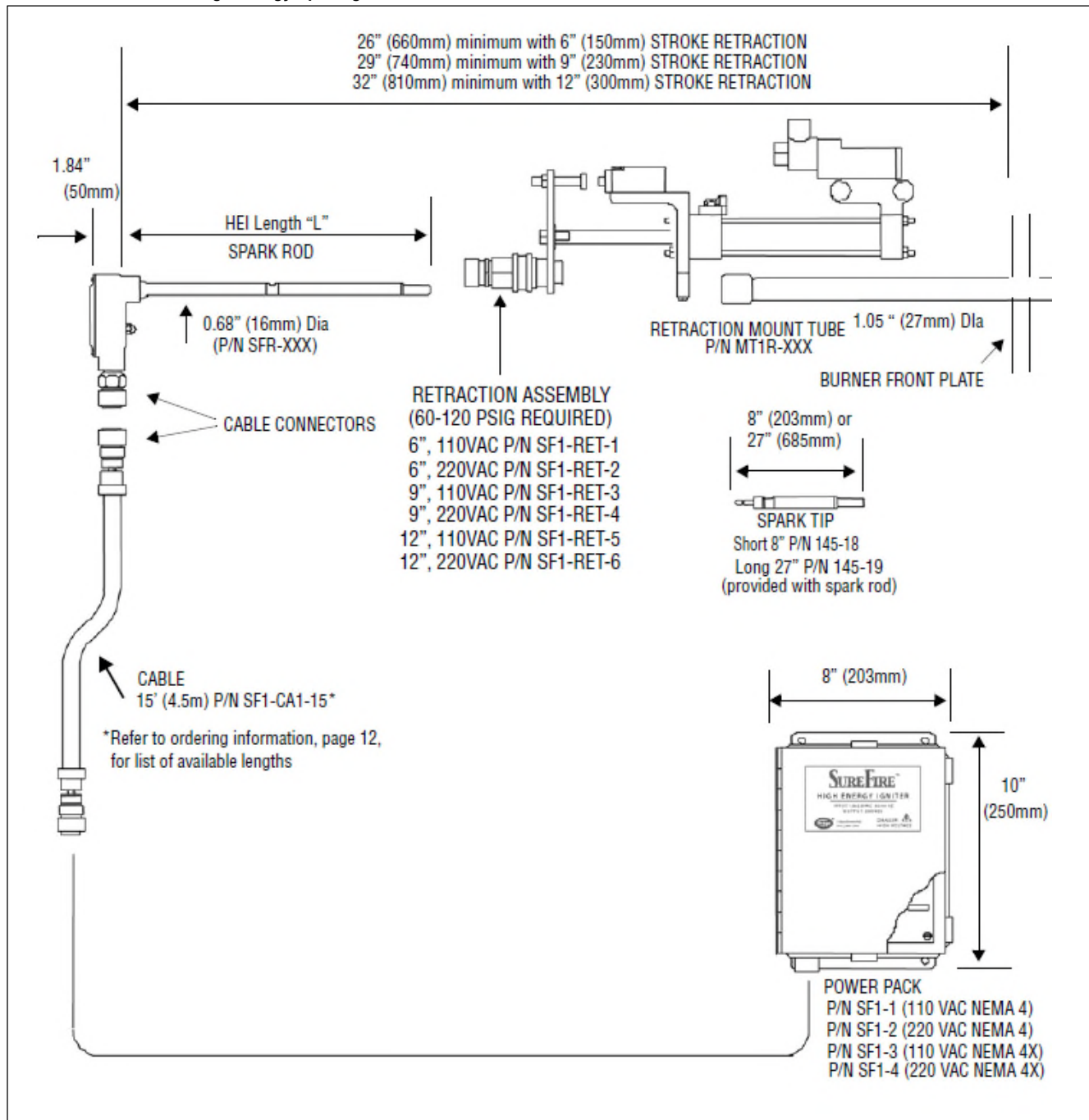



## SAFETY

Safety is the responsibility of each individual who installs, operates, or maintains Fireeye equipment. The Fireeye design of the HESI includes personnel safety as a basic design element.

The HESI assembly uses a 2000-vdc energy source to produce a 12-joule spark for fuel ignition purposes. Observe the following safety instructions as a minimum to ensure basic electrical safety.

1. Use equipment only for its intended use.



**WARNING: Hazardous voltage is present and serious injury can occur.**

2. Follow the proper installation, operation, and maintenance procedures discussed in this publication.
3. Ensure that all electrical apparatus used to perform work on this equipment is in good working order and calibrated correctly.
4. Do not lift or disconnect grounding cables/wires while equipment is energized.
5. Do not perform modifications on this equipment.
6. Before opening the power pack's hinged cover, disconnect the electrical supply from the box. Allow at least 2 minutes for the capacitor to discharge. Exercise extreme care when the power pack cover is open.
7. Before disconnecting terminals, place a voltmeter across terminals 1 and 2 of capacitor C1 to ensure that no voltage is present.
8. Adhere to safety-related information on all drawings.
9. Before applying the energizing signal to the assembly, fully connect the spark rod to the power unit.
10. When the HESI spark rod is removed from its operating position for testing, do not attempt to energize it without taking precautions. Lay the spark rod in a secure position. Ensure that personnel are not in contact with the spark rod during the test period. Replace the rod immediately following testing.



**WARNING: Only knowledgeable and qualified technicians should be allowed access to this system or to its components. The installation, maintenance, and operation of electronic equipment entails several elements of danger. Carelessness can result in serious injury or death from electrical shock, falls, or improper use of tools and test equipment**

## INSTALLATION

### POWER PACK

Observe the following steps for installing the power pack assembly:

1. Locate power pack away from extreme temperatures and as far away from burner front plate as possible. Allow for cable length, retraction, and boiler expansion.
2. Mount the power pack in a suitable location. Ensure that the cable connectors are facing down (power pack is upright) to facilitate cable installation

**FIGURE 4. High Energy Power Pack.**

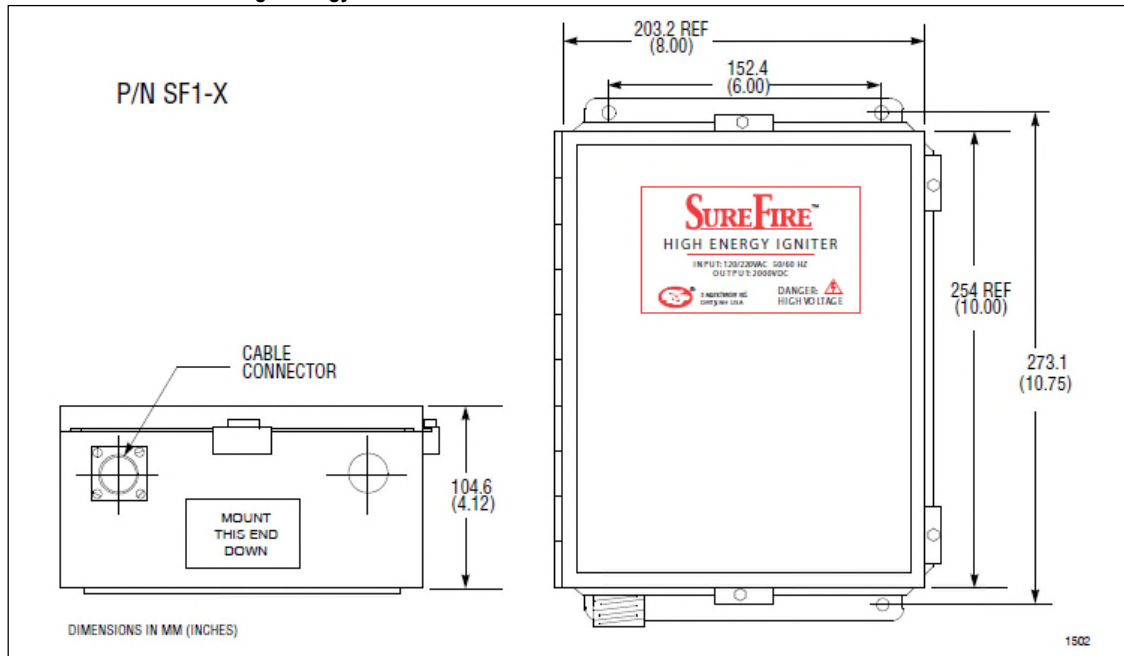

**SPARK ROD**

In most applications, the HESI spark rod fits into a guide tube that houses the spark rod assembly. Observe the following steps for installing the spark rod assembly:

1. Carefully insert the spark tip into the guide tube until the spark rod extends into the primary ignition zone. As a general guideline, with gas igniters position the spark tip flush with the front of the baffle plate (Fig. 5). With oil igniters, position the spark tip 3 to 4 inches past the oil gun tip (Fig. 6).
2. When a retraction assembly is supplied, exercise the retract cylinder, either manually or automatically, in the extend and retract positions to check for correct operation.
3. Once the tip penetration is set, attach and tighten the locking device to the spark rod.

**FIGURE 5.**

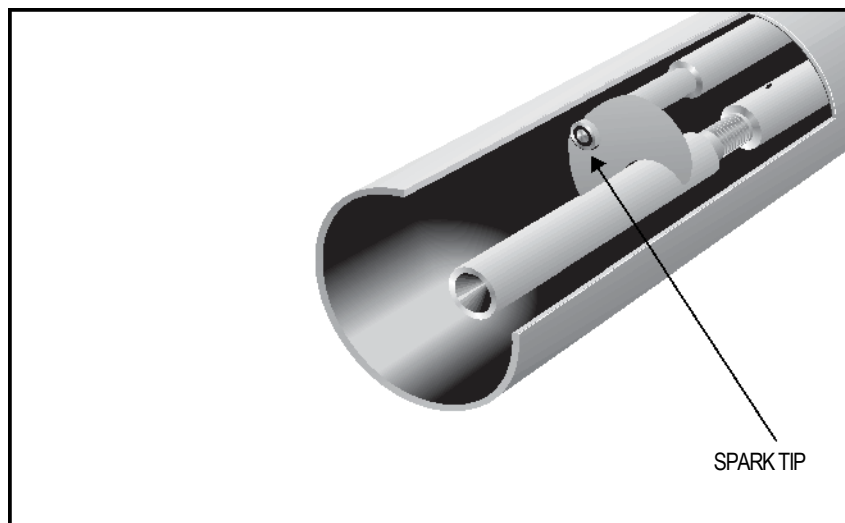



**FIGURE 6. LOCATION OF SPARK TIP IN OIL IGNITER**

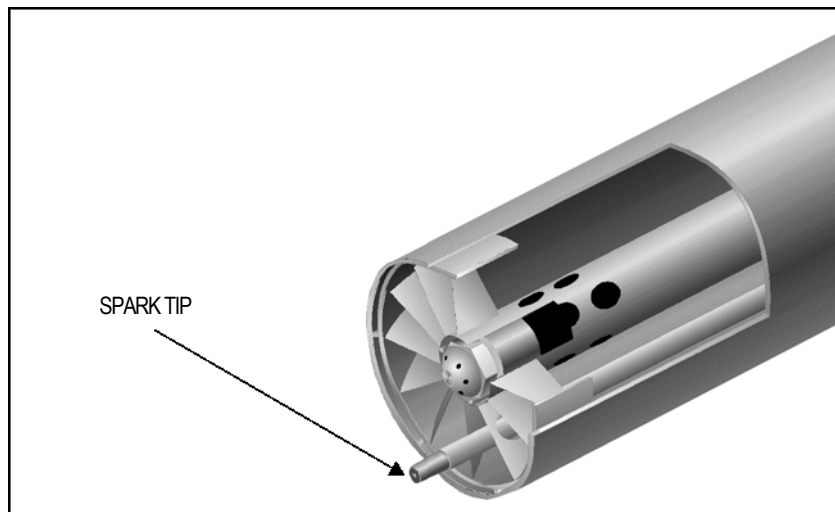

**CABLE ASSEMBLY**

1. Connect power input leads to TB2, H (hot), N (neutral), and G (ground) to the power pack as shown in installation drawings and in Fig. 7.

**FIGURE 7.**

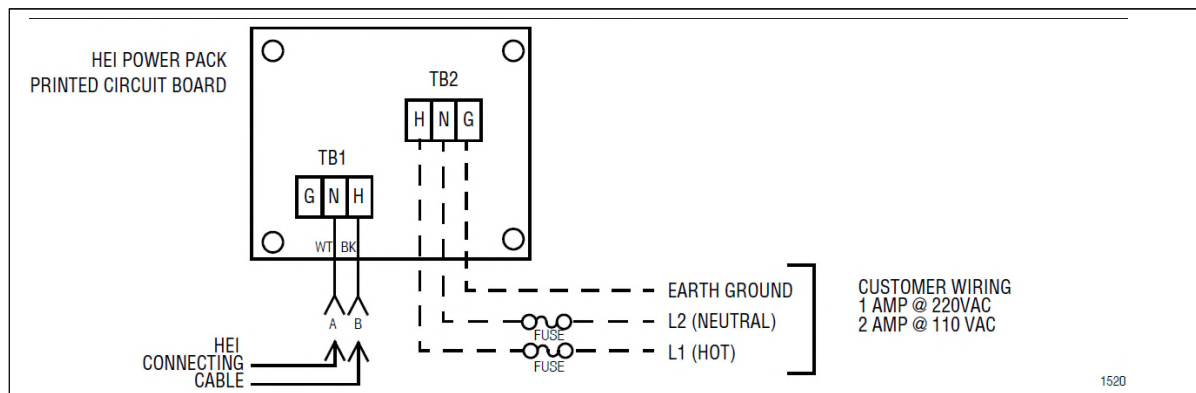

**COMMISSIONING**

When you have completed the installation, perform a spark test and observe spark rod operation in the following manner.

1. Energize the power pack and observe the operation of the ceramic spark gap or spark gap tube. This is mounted on the PC board, viewed with the power pack door open. A flashing of 180 sparks per minute indicates proper operation.
2. Observe the spark rod while the rod is still in the guide tube. The spark rod assembly is functioning properly when discharge of approximately three sparks per second is visible. If the spark rod cannot be observed in place, mark the rod so it can be repositioned to its previous location. Remove the rod and place it in a safe location away from any personal contact. Observe the rod for visible emission of three sparks per second. If the spark rod assembly functions properly, reinsert the rod into the guide tube at the rod's original position.
3. If the rod functions properly, energize the system to observe the rod's performance with its associated fuel gun. Check the following items: igniter fuel pressure, atomizing media pressure, and combustion air pressure. (Refer to the SureFire Igniter bulletin for pressure specifications.) If the HESI system functions properly, but the igniter does not light, the HESI rod may need repositioning.



## OPERATION

The HESI igniter is a Class 3 ignition source and is only in service during an ignition time trial duration. The HESI can operate during ignition and during oil gun shutdown and purge. Depending on the application, the spark rod can be set in a fixed position or attached to a retraction assembly to move it out of firing position. The spark rod should be fitted with the retraction assembly whenever the HESI spark rod tip will be exposed to continuous temperatures above 149° C (300° F).

The burner management system provides the control signal that energizes the HESI during the ignition time trial period. The power unit transforms the signal into short 12-joule discharges at the rate of three sparks per second. The cable assembly transmits these discharges to the spark rod assembly.

## TROUBLESHOOTING

If the HESI assembly malfunctions, ensure that the procedures described in the Commissioning Section have been performed successfully. If problems persist, refer to Table 1 for troubleshooting information.

Table 1: Troubleshooting

SYMPTOM	PROBABLE CAUSE	REMEDY
Ceramic spark gap or spark gap tube not flashing.	1. Input voltage low. 2. Power pack failure.	1. Provide correct voltage. 2. Replace power pack.
Ceramic spark gap or spark gap tube weak or erratic.	1. Spark tip fouled and shorting 2. Tip insulator cracked or damaged. 3. High tension cable inside rod broken or insulation damaged.	1. Replace tip assembly and adjust tip to gun setting as specified in drawing. 2. Replace tip assembly and adjust tip to gun setting as specified in drawing. 3. Replace cable assembly. Adjust tip to gun settings on specified drawing.



**WARNING: Hazardous voltage is present and serious injury to personnel can occur. Before opening the power pack's hinged cover, disconnect the electrical supply from the box. Allow at least 2 minutes for the capacitor to discharge. Exercise extreme care when the power pack cover is open.**

## MAINTENANCE

Fireye recommends performing the following preventive maintenance every six

### months. SPARK TIP INSPECTION AND MAINTENANCE

Remove the spark rod from the guide tube and inspect the spark tip for damage due to overheating, excessive use, and mishandling of equipment. A concave shape of the spark tip end represents normal wear. If the semiconductor material is chipped, cracked, or eroded, replace the spark tip. If the inner electrode, tip center, or tube shows deterioration, wear, or erosion, also replace the spark tip. When replacing the spark tip, observe the following steps:

1. Disconnect all electric power from the power unit and ensure that all residual voltage is dissipated. (See Safety section.)
2. Remove and replace tip using 1/2 inch wrench flats.



## POWER PACK INSPECTION AND MAINTENANCE

The following steps describe power pack inspection and maintenance.

1. Disconnect all electric power from the power pack, and ensure that all residual voltage is dissipated. (See Safety section.)
2. Open the power pack door.
3. Test capacitor C1 for resistance across terminals 1 and 2.
4. Test transformer T1 for resistance at the two red secondary leads.
5. An open circuit reading on capacitor C1 and/or a low resistance value reading at transformer T1 indicates a normal condition. If a normal condition is present, circuitry problems could exist elsewhere. Replace the power pack.

The power pack generally does not need periodic maintenance other than cleaning the exterior and checking the hinged cover for proper closure and sealing.

## SPARK GAP OPERATION VERIFICATION

A visible flashing of the ceramic spark gap or spark gap tube indicates the presence of electric-discharge voltage and delivery to the spark tip. This is viewed with the power pack door open.

## CABLE INSPECTION AND MAINTENANCE

Inspect the cable for fraying or loose connections. Replace frayed cable.

---

## RECOMMENDED SPARE PARTS

The following recommended spare parts table advises of the minimum stock level of replacement parts that should be in the customer's stock for system start-up and the first year of operation. Recommended replacement parts should be ordered as necessary to maintain the suggested level of spare parts.

Item	Part Number	Quantity
Spark Tip, Short (Spark Rods 36" and shorter)	145-18	1 for every 4 igniters
Spark Tip, Long (Spark Rods greater than 36")	145-19	1 for every 4 igniters
Solenoid & Coil for Retract Assembly, 110 vac	8-705	1 for every 5 igniters
Solenoid & Coil for Retract Assembly, 220 vac	8-706	1 for every 5 igniters
Coil Only for Retract Assembly, 110 vac	70-426	1 for every 5 igniters
Coil Only for Retract Assembly, 220 vac	70-427	1 for every 5 igniters
Powerpack Spark Gap Tube Replacement Kit	129-174	1 for every 5 igniters
Powerpack Capacitor	7-1738	1 for every 5 igniter
Powerpack Transformer	5-563	1 for every 5 igniters



## ORDERING INFORMATION: FIXED MOUNT HESI IGNITER

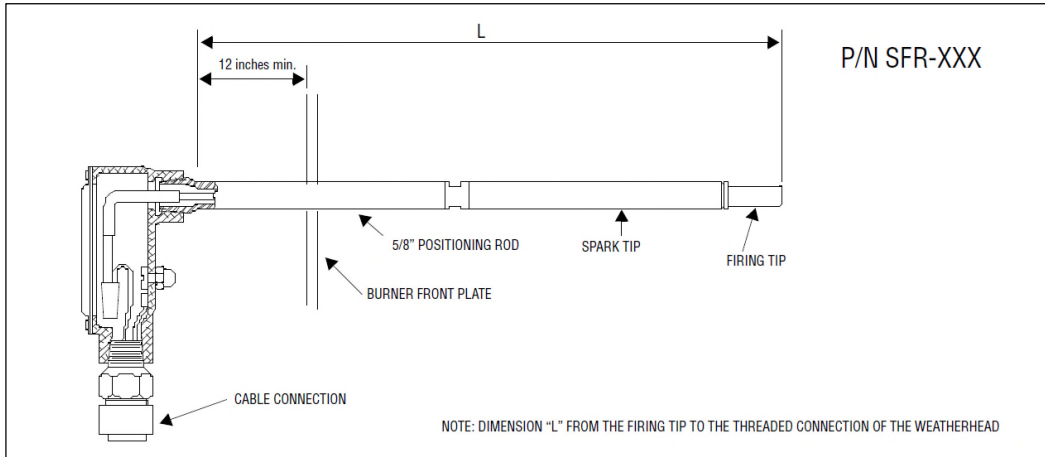

### FIXED MOUNT HESI IGNITER SPECIFICATION STEPS (Refer to figure 2)

1. Select the appropriate HESI Power Pack (P/N SF1-X).
2. Select the appropriate HESI Interconnecting Cable (P/N SF1-CA1-XX).
3. Select the appropriate HESI Rod, (P/N SFR-XXX), taking note of the 12" minimum external length.
4. Select the appropriate optional *fixed* mounting tube (P/N MT1-XXX).

### 1. SELECT THE APPROPRIATE HESI POWER PACK

PART NUMBER	DESCRIPTION
SF1-1	SureFire HESI Power Pack, 110 vac, NEMA 4 (painted steel)
SF1-2	SureFire HESI Power Pack, 220 vac, NEMA 4 (painted steel)
SF1-3	SureFire HESI Power Pack, 110 vac, NEMA 4X (stainless steel)
SF1-4	SureFire HESI Power Pack, 220 vac, NEMA 4X (stainless steel)

### 2. SELECT THE APPROPRIATE HESI INTERCONNECTING CABLE

PART NUMBER	DESCRIPTION
SF1-CA1-06	SureFire HESI interconnecting cable with connectors, 6 feet long
SF1-CA1-09	SureFire HESI interconnecting cable with connectors, 9 feet long
SF1-CA1-12	SureFire HESI interconnecting cable with connectors, 12 feet long
SF1-CA1-15	SureFire HESI interconnecting cable with connectors, 15 feet long
SF1-CA1-20	SureFire HESI interconnecting cable with connectors, 20 feet long
SF1-CA1-25	SureFire HESI interconnecting cable with connectors, 25 feet long
SF1-CA1-50	SureFire HESI interconnecting cable with connectors, 50 feet long



### 3. SELECT THE APPROPRIATE SUREFIRE HESI SPARK ROD

The spark rod part number will start with “SF1”, followed by three digits. These three digits specify the rod length (in inches) available in two inch increments from 14” (“014”) to 180” (“180”).

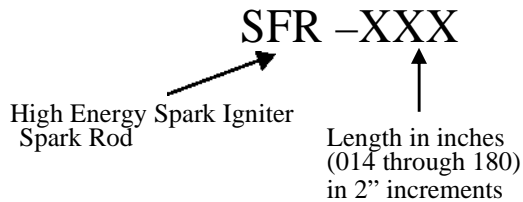

**EXAMPLE:** Specify a SureFire HESI Spark Rod - 72 inches long.

Specify part number: **SFR – 072**

### 4. SELECT OPTIONAL HESI MOUNTING TUBE (Fixed)

PART NUMBER	DESCRIPTION
MT1-006	Fixed Mount Tube 6” long (rod lengths 014 through 020)
MT1-016	Fixed Mount Tube 16” long (rod lengths 022 through 030)
MT1-026	Fixed Mount Tube 26” long (rod lengths 032 through 040)
MT1-036	Fixed Mount Tube 36” long (rod lengths 042 through 050)
MT1-046	Fixed Mount Tube 46” long (rod lengths 052 through 060)
MT1-056	Fixed Mount Tube 56” long (rod lengths 062 through 070)
MT1-066	Fixed Mount Tube 66” long (rod lengths 072 through 080)
MT1-076	Fixed Mount Tube 76” long (rod lengths 082 through 090)
MT1-086	Fixed Mount Tube 86” long (rod lengths 092 through 100)
MT1-096	Fixed Mount Tube 96” long (rod lengths 102 through 110)
MT1-106	Fixed Mount Tube 106” long (rod lengths 112 through 120)
MT1-116	Fixed Mount Tube 116” long (rod lengths 122 through 130)
MT1-126	Fixed Mount Tube 126” long (rod lengths 132 through 140)
MT1-136	Fixed Mount Tube 136” long (rod lengths 142 through 150)
MT1-146	Fixed Mount Tube 146” long (rod lengths 152 through 160)
MT1-156	Fixed Mount Tube 156” long (rod lengths 162 through 170)
MT1-166	Fixed Mount Tube 166” long (rod lengths 172 through 180)



## ORDERING INFORMATION: RETRACTABLE MOUNT HESI IGNITER

### RETRACTABLE HESI IGNITER SPECIFICATION STEPS (Refer to figure 3)

1. Select the appropriate HESI Power Pack (P/N SF1-X).
2. Select the appropriate HESI Interconnecting Cable (P/N SF1-CA1-XX).
3. Select the appropriate HESI Rod, (P/N SFR-XXX), taking note of the minimum external (retracted) length shown on Figure 3.
4. Select the appropriate Retractor Assembly (P/N SF1-RET-X).
5. Select the appropriate optional *retraction* mounting tube (P/N MT1R-XXX).

#### 1. SELECT THE APPROPRIATE HESI POWER PACK

PART NUMBER	DESCRIPTION
SF1-1	SureFire HESI Power Pack, 110 vac, NEMA 4 (painted steel)
SF1-2	SureFire HESI Power Pack, 220 vac, NEMA 4 (painted steel)
SF1-3	SureFire HESI Power Pack, 110 vac, NEMA 4X (stainless steel)
SF1-4	SureFire HESI Power Pack, 220 vac, NEMA 4X (stainless steel)

#### 2. SELECT THE APPROPRIATE HESI INTERCONNECTING CABLE

PART NUMBER	DESCRIPTION
SF1-CA1-06	SureFire HESI interconnecting cable with connectors, 6 feet long
SF1-CA1-09	SureFire HESI interconnecting cable with connectors, 9 feet long
SF1-CA1-12	SureFire HESI interconnecting cable with connectors, 12 feet long
SF1-CA1-15	SureFire HESI interconnecting cable with connectors, 15 feet long

#### 3. SELECT THE APPROPRIATE SUREFIRE HESI SPARK ROD

The spark rod part number will start with “SF1”, followed by three digits. These three digits specify the rod length (in inches) available in two inch increments from 14” (“014”) to 180” (“180”).

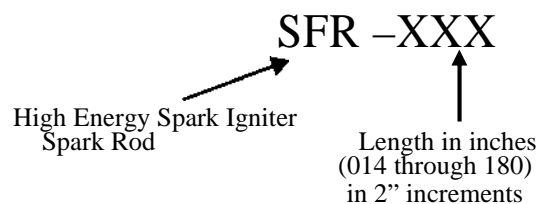

**EXAMPLE:** Specify a SureFire HESI Spark Rod - 72 inches long. Specify part number: **SFR – 072**



**4. SELECT THE APPROPRIATE RETRACTOR ASSEMBLY**

PART NUMBER	DESCRIPTION
SF1-RET-1	Retractor Assembly, 6" Stroke, 110 vac solenoid.
SF1-RET-2	Retractor Assembly, 6" Stroke, 220 vac solenoid.
SF1-RET-3	Retractor Assembly, 9" Stroke, 110 vac solenoid.
SF1-RET-4	Retractor Assembly, 9" Stroke, 220 vac solenoid.
SF1-RET-5	Retractor Assembly, 12" Stroke, 110 vac solenoid.
SF1-RET-6	Retractor Assembly, 12" Stroke, 220 vac solenoid.

**5. SELECT THE APPROPRIATE RETRACTION MOUNTING TUBE**

The Retraction Mounting Tube part number will start with "MT1R", followed by three digits. These three digits specify the Retraction Mounting Tube length (in inches), available in two inch increments from 28" (028) to 170" (170).

**Important Note:** You must specify a Retraction Mounting Tube that is at least 10" shorter than the HESI Spark Rod specified in step 3 (above).

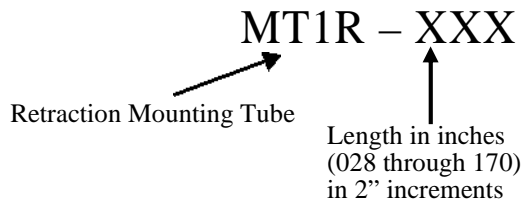

**EXAMPLE:** Specify a Retraction Mounting Tube for a 72 inch long SureFire HESI Spark Rod (P/N SFR-072). Specify part number: **MT1R – 062**



---

## NOTICE

When Fireeye products are combined with equipment manufactured by others and/or integrated into systems designed or manufactured by others, the Fireeye warranty, as stated in its General Terms and Conditions of Sale, pertains only to the Fireeye products and not to any other equipment or to the combined system or its overall performance.

---

## WARRANTIES

FIREYE guarantees for *one year from the date of installation or 18 months from date of manufacture* of its products to replace, or, at its option, to repair any product or part thereof (except lamps, electronic tubes and photocells) which is found defective in material or workmanship or which otherwise fails to conform to the description of the product on the face of its sales order. **THE FOREGOING IS IN LIEU OF ALL OTHER WARRANTIES AND FIREYE MAKES NO WARRANTY OF MERCHANTABILITY OR ANY OTHER WARRANTY, EXPRESS OR IMPLIED.** Except as specifically stated in these general terms and conditions of sale, remedies with respect to any product or part number manufactured or sold by Fireeye shall be limited exclusively to the right to replacement or repair as above provided. In no event shall Fireeye be liable for consequential or special damages of any nature that may arise in connection with such product or part.