



FIREYE® TYPE “EC” SCANNERS, CABLE AND ACCESSORIES

DESCRIPTION

This bulletin describes Fireeye type “EC” flame scanners, cables, and scanner accessories developed specifically for use with Fireeye model 25SU3-2150 Flame Safeguard Amplifier. These products have been designed for enhanced immunity to the sources of external electrical interference present in many industrial installations.

FIREYE TYPE “EC” FLAME SCANNERS

All listed scanners include a factory installed 90 degree male cable quick disconnect (see note 2). For scanner application notes, mechanical installation, alignment, and calibration procedures, refer to the appropriate scanner bulletin listed below. **For scanner cable wiring details, refer to the 25SU3-2150 amplifier bulletin, CU-54.**

TYPE/MODEL	FREQ. Hz	WAVE-LENGTH (nanometers)	MOUNT THREADS	SAFETY APPROVALS	BULLETIN	NOTES
45UV5-1000EC	60	180 - 250	1" NPT	FM, CSA	CU-22	1
45UV5-1010EC	60	180 - 250	1" BSP	FM, CSA	CU-22	1
45UV5-1101EC	50	180 - 250	1" BSP	FM, CSA, DIN-DVGW, CE		1 and 2
45RM1-1001EC	50/60	450 - 1,000	1" NPT	FM, CSA	CU-26	1
45RM1-1003EC	50/60	450 - 1,000	1" BSP	FM, CSA, DIN-DVGW, CE	CU-26	1 and 2
61-4892-2EC	50/60	450 - 1,000	Fiber Optic	FM, CSA	CU-26, CU-21	1 (45RM1)
45RM2-1000EC	50/60	700 - 2,500	1" NPT	FM, CSA	CU-26	1
45RM2-1001EC	50/60	700 - 2,500	1" BSP	FM, CSA, DIN-DVGW, CE	CU-26	1 and 2
61-5234EC	50/60	700 - 2,500	Fiber Optic	FM, CSA	CU-26, CU-21	1 (45RM2)
45RM4-1000EC	24VDC	700 - 2,500	1" NPT	FM, CSA	CU-31	1
45RM4-1001EC	24VDC	700 - 2,500	1" BSP	FM, CSA, DIN-DVGW, CE	CU-31	1 and 2
61-6521EC	24VDC	700 - 2,500	Fiber Optic	FM, CSA	CU-31, CU-21	1 (45RM4)

Note 1: Existing model 45UV5, 45RM1 and 45RM2 scanners can be converted to “EC” versions in the field by installing the appropriate 90° electrical connector assembly, P/N 60-2625-1, listed on page 2. Existing model 45RM4 scanners cannot be converted in the field.

Note 2: APAVE Agency approval pending.



TYPE "EC" SCANNER CABLE, AND FEMALE CONNECTOR KITS (Require Field Assembly)

PART NUMBER	DESCRIPTION
59-491	Scanner cable, 4 conductor, EMI shielded (ordered by the foot)
129-158-1	Connector kit, female, use with 4 conductor 59-491 cable. For mating with type "EC" scanner, and for field cable splices
129-160-1	Connector kit, male, use with 4 conductor 59-491 cable. For field cable splices, (mates with 129-158-1)

PRE-ASSEMBLED "EC" SCANNER CABLE WITH FEMALE CONNECTOR

PART NUMBER	DESCRIPTION
59-491-010	10' Cable Assembly, 4 conductor, with 129-158-1 conn. installed
59-491-020	20' Cable Assembly, 4 conductor, with 129-158-1 conn. installed
59-491-040	40' Cable Assembly, 4 conductor, with 129-158-1 conn. installed
59-491-050	50' Cable Assembly, 4 conductor, with 129-158-1 conn. installed
59-491-060	60' Cable Assembly, 4 conductor, with 129-158-1 conn. installed
59-491-080	80' Cable Assembly, 4 conductor, with 129-158-1 conn. installed
59-491-100	100' Cable Assembly, 4 conductor, with 129-158-1 conn. installed
59-491-120	120' Cable Assembly, 4 conductor, with 129-158-1 conn. installed
59-491-140	140' Cable Assembly, 4 conductor, with 129-158-1 conn. installed
59-491-160	160' Cable Assembly, 4 conductor, with 129-158-1 conn. installed
59-491-180	180' Cable Assembly, 4 conductor, with 129-158-1 conn. installed
59-491-200	200' Cable Assembly, 4 conductor, with 129-158-1 conn. installed
59-491-250	250' Cable Assembly, 4 conductor, with 129-158-1 conn. installed
59-491-300	300' Cable Assembly, 4 conductor, with 129-158-1 conn. installed

REPLACEMENT 90 DEGREE MALE CONNECTOR (for type "EC" scanners)

PART NUMBER	FITS THE FOLLOWING TYPE "EC" SCANNER MODELS
60-2625-1	45UV5, 45RM1, 45RM2, 61-4892-2EC, 61-5234EC (also used for field upgrade, see note 1).
60-2625-2	45RM4, 61-6521EC

Note 1: Existing models 45UV5 and 45RM2 scanners can be converted to "EC" versions in the field by installing the appropriate 90° electrical connector assembly, P/N 60-2625-1. Existing model 45RM4 scanners cannot be converted in the field.

FIELD ASSEMBLY INSTRUCTIONS FOR TYPE "EC" CABLE CONNECTORS

FIGURE 1.

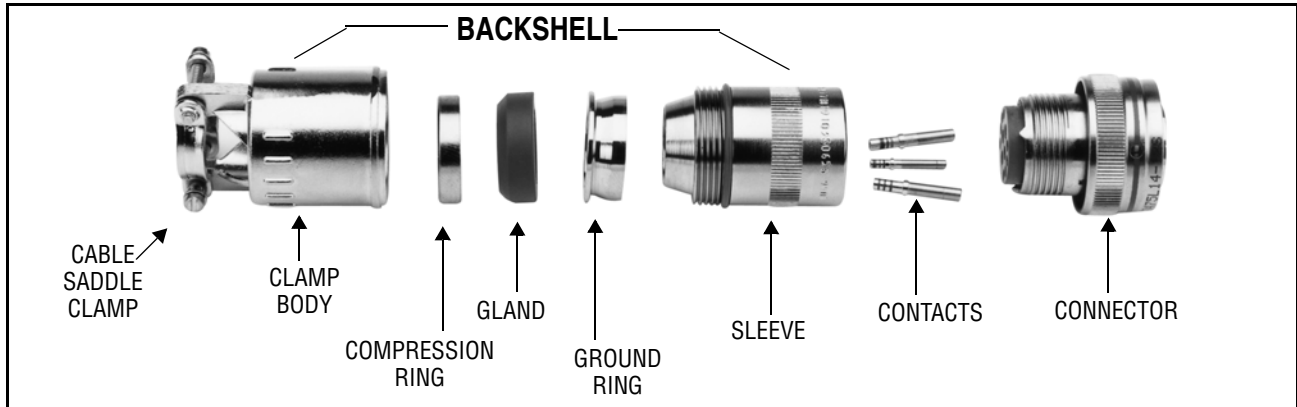

1. For ease of assembly, select the cable "end" where the conductors are oriented as shown.

FIGURE 2.

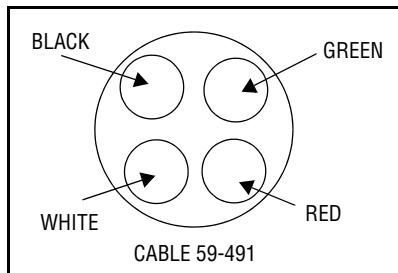

2. Slide shrink tubing and connector backshell over the cable jacket.
3. Strip cable outer jacket.

FIGURE 3.

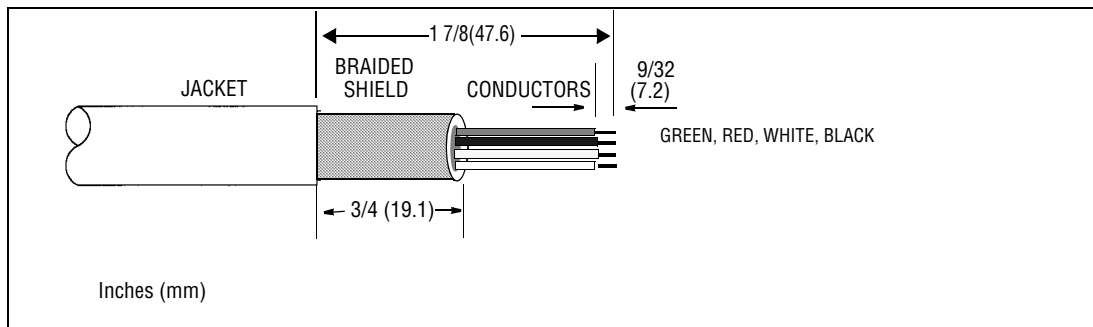

4. Strip conductor insulation as shown.
5. Loosen braid by pushing back and forth on cable.
6. Fold braided shield back over jacket and trim excess foil, clear tape and rubber filler. Temporarily secure braid with tape.

FIGURE 4.

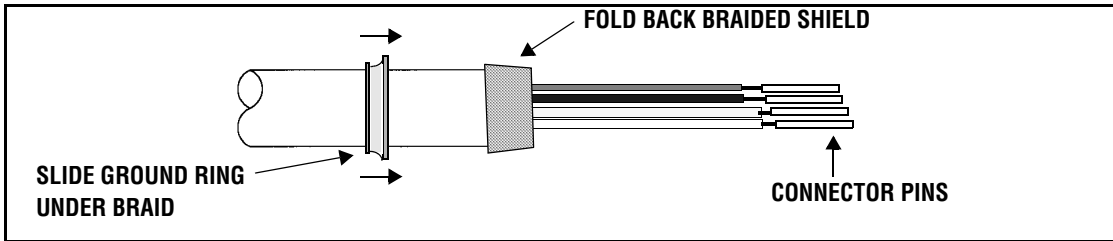

7. Install female contacts onto conductors and crimp carefully.
(Use Mil Spec. crimp tool # M22520/1-01 with #MM22520/1-02 turret).
#18 contacts: Green, Red, White and Black (“Blue” locator of crimping tool).
8. Insert hole fillers (provided) from the rear, into unused holes of connector.
9. Insert wires and female contacts into connector. Contacts “click” in place.

NOTE: Contacts may be removed with tool provided with the connector kit. Use white end of blue tool for 18 gauge wires.

FIGURE 5.

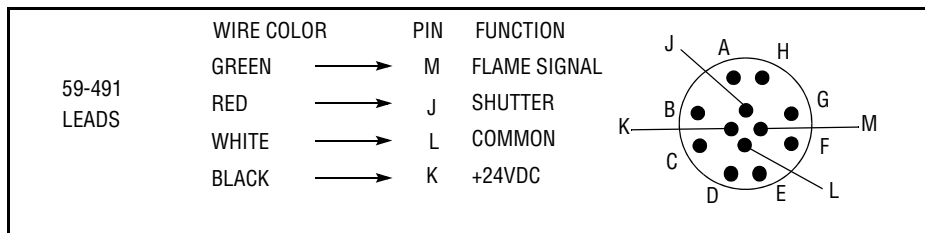

10. Thread backshell sleeve into connector and torque to 100-150 in-lb. (11.3-17 Nt.-M).
11. Slide ground ring under braided shield and capture braid between ground ring and backshell sleeve. Fold excess braiding over ground ring.
12. Thread cable clamp into backshell sleeve and torque to 100-150 in-lb. (11.3-17 Nt.-M).
13. Slide shrink tubing against cable clamp and shrink.
14. Install and tighten cable saddle clamp.

SCANNER AND AMPLIFIER CABLING METHODS

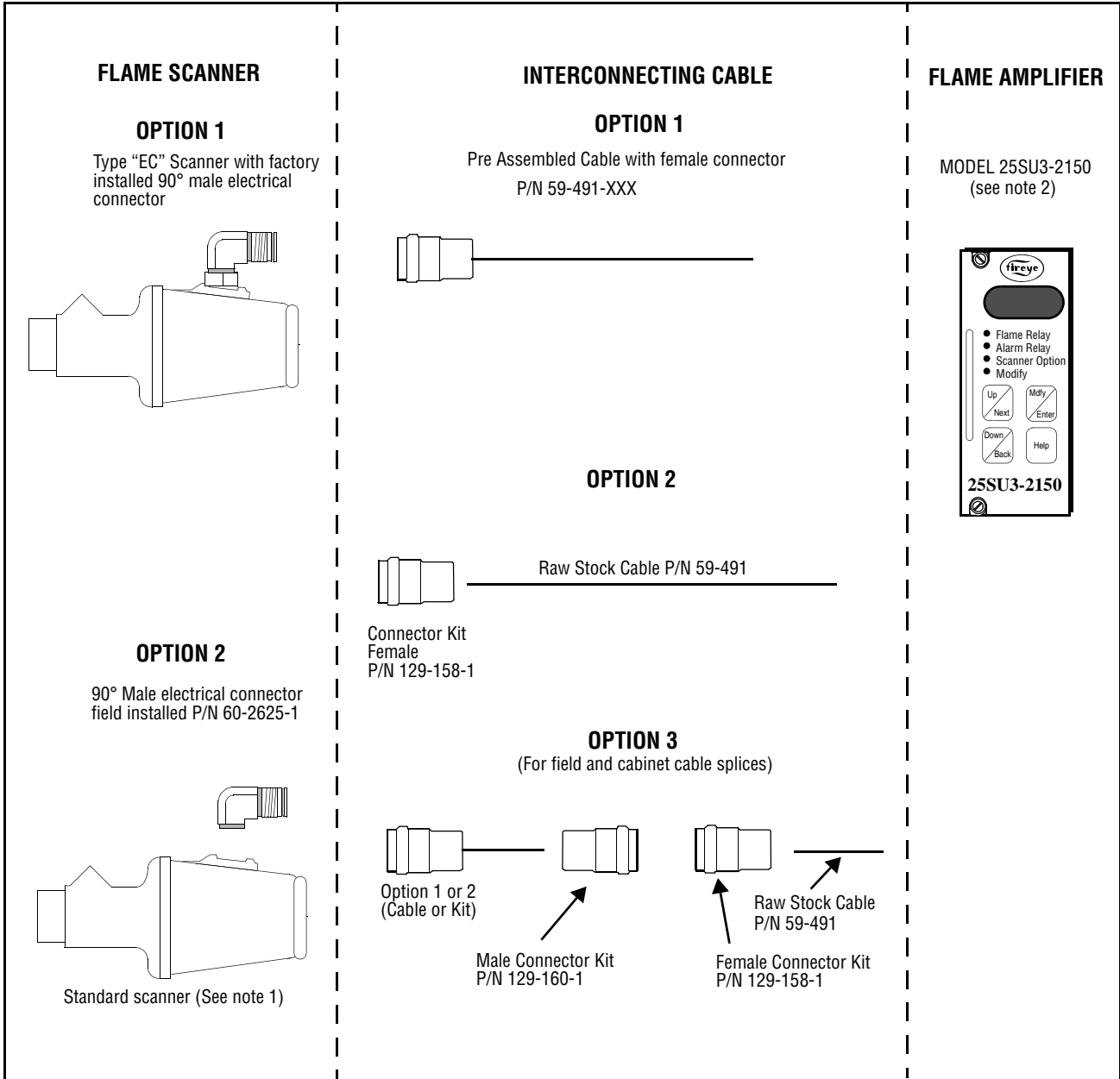

Note 1: Existing model 45UV5, 45RM1 and 45RM2 scanners can be converted to "EC" versions in the field by installing the appropriate 90° electrical connector assembly, P/N 60-2625-1, listed on page 2. Existing model 45RM4 scanners cannot be converted in the field.

Note 2: Model 25SU3-2150 amplifier is to be installed in cardrack, P/N 60-2471-1EC,-2EC, which includes P/N 61-6898-1 connector kit. Existing cardracks, P/N 60-2471-1, -3, can be converted to "EC" models in the field by installing 61-6898-1 connector kit or 61-6898-2 EMI filter board and bus bar. Refer to bulletin CU-54.

FIELD ASSEMBLY INSTRUCTIONS FOR TYPE “EC” SCANNER CONNECTOR

The following describes the steps required to replace the scanner connector on any type “EC” scanner. These steps also apply to installing the type “EC” connector on an existing model 45UV5, 45RM1 or 45RM2 scanner. (These steps *do not* apply to existing model 45RM4 scanners with “Harting” connectors).

FIGURE 6. FIELD REPLACEMENT OF TYPE “EC” ELECTRICAL CONNECTOR

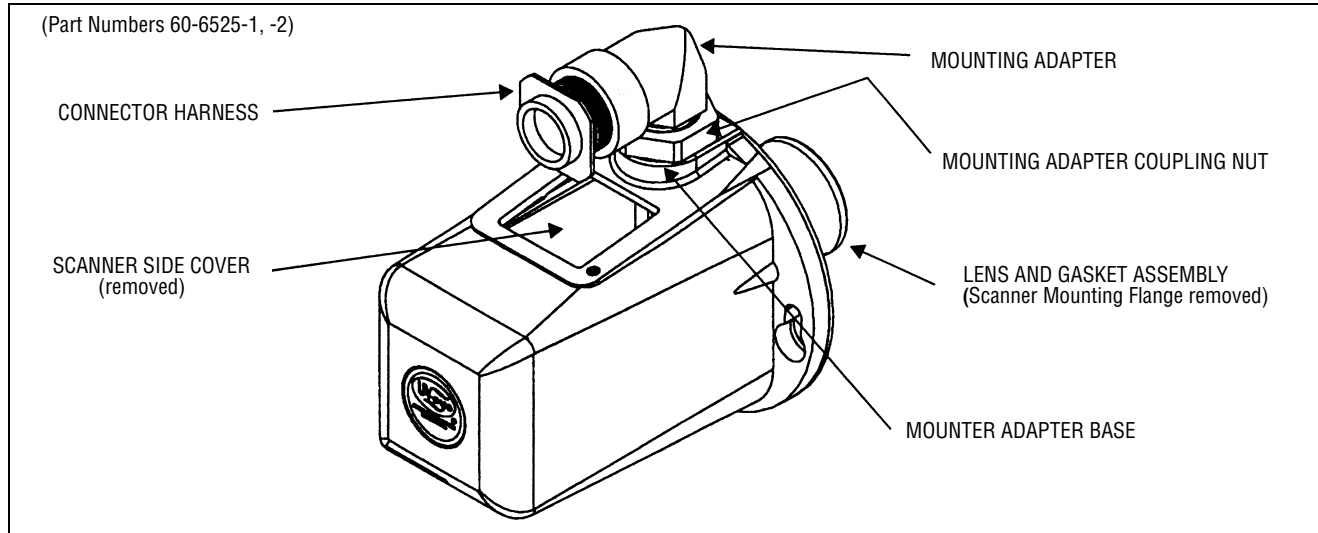

PREPARE THE SCANNER (refer to figure 6)

1. Remove scanner mounting flange.
2. Remove scanner side cover.
3. Remove lens and gasket assembly. With models 45RM1 and 45RM2 the entire electronics assembly will slide out of the housing, exposing the four terminal screws.
4. 45UV5, 45RM1 and 45RM2 Scanners: Remove old scanner connector, if applicable.
5. 45RM4 Scanners only: Carefully pull the electronics assembly 1 1/2" out of the scanner housing to expose the connector harness and printed circuit board connector.

Remove connector harness, noting it's position:

The 45RM4 connector harness will have four wires in an eight pin connector. The connector key plug faces the printed circuit board. The connector identification mark “1” faces the inside of the scanner.

Remove old scanner connector.

FIGURE 7. CONNECTOR EXPLODED VIEW

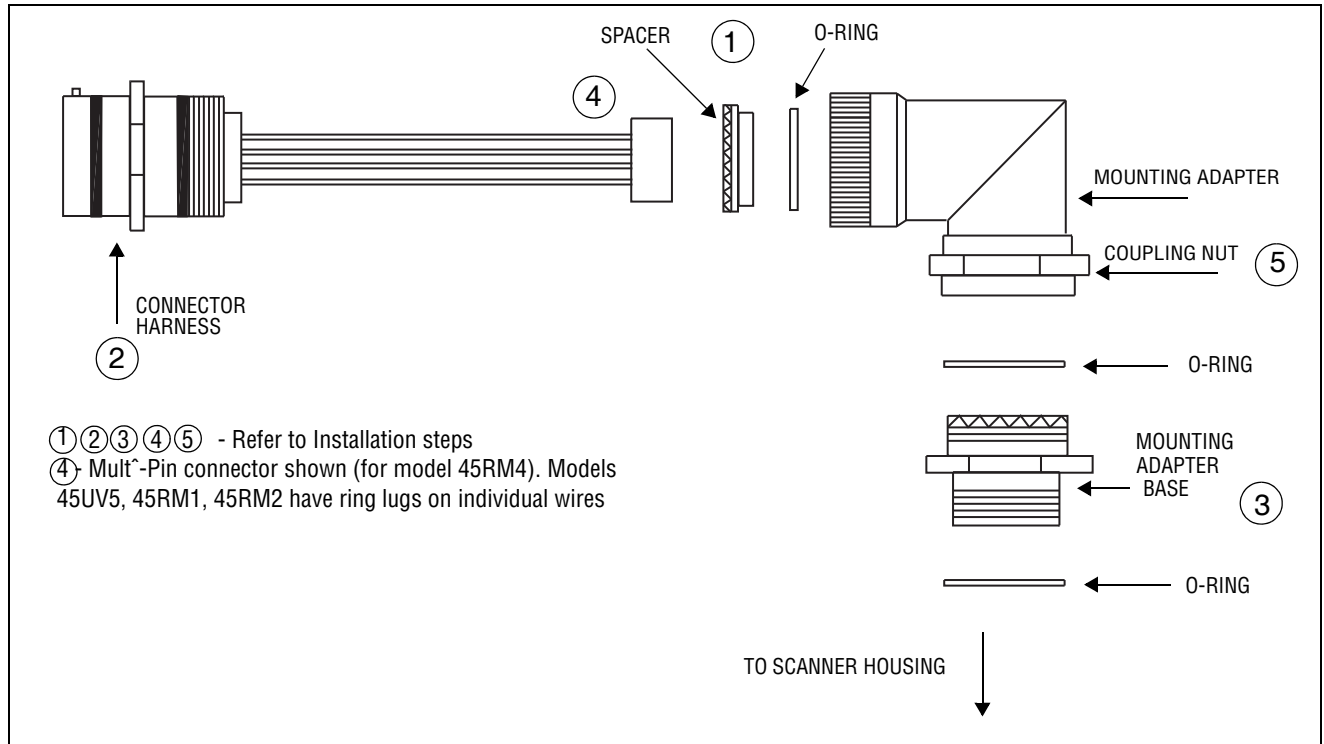

CONNECTOR INSTALLATION STEPS

1. Seat the connector o-ring and spacer ring (teeth facing out) into the right-angle section of the connector mounting adapter.
2. Assemble the connector harness to the right-angle section of the connector mounting adapter and tighten to between 100 - 150 in.-lbs (11.3 -17 NT. - M).
3. Seat the two o-rings into the two grooves of the connector mounting adapter base. Assemble the adapter base to the scanner housing and tighten to between 100 - 150 in.-lbs (11.3 -17 NT. - M).
4. Feed the wires from the connector harness into the scanner through the connector adapter base.
5. Thread the mounting adapter coupling nut onto the mounting adapter base and tighten to between 100 - 150 in.-lbs (11.3 -17 NT. - M).
6. Attach the *individual wires* (models 45UV5, 45RM1 and 45RM2), or the *harness connector* (model 45RM4) to the scanner as follows:

WIRE COLOR CODE/ SCANNER TERMINALS

MODEL	BLACK	WHITE	RED	GREEN
45UV5	L	C	1	14
45RM1	P	C	1	14
45RM2	P	C	1	14

HARNESS CONNECTOR INSTALLATION

MODEL	INSTRUCTIONS
45RM4	The eight pin connector key plug faces the printed circuit board. The connector identification mark "1" faces the inside of the scanner.



NOTICE

When Fireeye products are combined with equipment manufactured by others and/or integrated into systems designed or manufactured by others, the Fireeye warranty, as stated in its General Terms and Conditions of Sale, pertains only to the Fireeye products and not to any other equipment or to the combined system or its overall performance.

WARRANTIES

FIREYE guarantees for *one year from the date of installation or 18 months from date of manufacture* of its products to replace, or, at its option, to repair any product or part thereof (except lamps, electronic tubes and photocells) which is found defective in material or workmanship or which otherwise fails to conform to the description of the product on the face of its sales order. **THE FOREGOING IS IN LIEU OF ALL OTHER WARRANTIES AND FIREYE MAKES NO WARRANTY OF MERCHANTABILITY OR ANY OTHER WARRANTY, EXPRESS OR IMPLIED.** Except as specifically stated in these general terms and conditions of sale, remedies with respect to any product or part number manufactured or sold by Fireeye shall be limited exclusively to the right to replacement or repair as above provided. In no event shall Fireeye be liable for consequential or special damages of any nature that may arise in connection with such product or part.



FIREYE
3 Manchester Road
Derry, New Hampshire 03038 USA
www.Fireeye.com

CU-55
APRIL 15, 2013
Supersedes September 13, 2005
