



# INSTALLATION INSTRUCTIONS FOR THE PHOENIX FIBER OPTIC FLAME SCANNERS

---

## APPLICATION

The FIREYE<sup>®</sup> fiber optic scanners have been designed for installation on burners where movable vanes, air compartments, or burner nozzles would obscure or move the target flame away from the line of sight of a conventional surface mounted scanner. In boiler applications where the individual burner flames tend to form a fireball, the Fireeye fiber optic scanner can detect the presence of an individual burner's flame, provided that the fuel ignites before entering the furnace fireball.

The Fireeye fiber optic scanner assembly includes an objective lens, which is mounted near the interface of the windbox and furnace. The fiber optic bundle is enclosed within a series of flexible stainless steel tubes, and brings the flame radiation to the detector within the Fireeye scanner electronics assembly, located outside the windbox. The inner carrier assembly containing the fiber optics is inserted into an outer carrier, and the scanner electronics is then attached. The outer carrier assembly is permanently fastened to the boiler.

---

## SPECIFICATIONS

### MATERIALS:

**Electronics housing:** Cast aluminum

**Inner and outer carriers:**

Hexagonal mounting head: 303 stainless steel.

Forward portions: flexible stainless steel; Rear portions: rigid black iron pipe.

Optics: High temperature glass or quartz.

**DIMENSIONS:** See Figure 1.

### MOUNTING:

**Front:** Hexagonal head, 1 1/2" across flats x 1 3/4" long, welded into mechanism that follows burner motion.

**Rear:** Rigid 1" pipe welded to windbox wall.

Optional compression fitting with flange, P/N 60-2806.

**Electronics:** Fastened to inner carrier with two 1/4-20 studs and nuts.

**ELECTRICAL:** Refer to Phoenix scanner bulletin CU-105.

## SPECIFICATIONS (Continued)

### PURGE AIR:

- Source:** Provided by customer
- Connections:** 3/8" female NPT at scanner flange  
1" female NPT at outer carrier pipe "Y."
- Volume required:** 4 - 15 SCFM (113 - 425 L/M) at either the 1" NPT or 3/8" NPT tap.  
Minimum applied pressure should be 10" WC above furnace pressure.

### TEMPERATURE:

- Electronics:** Model 85IRF, 85UVF: -40°F (-40°C) min., 150°F (65°C) max.

- Fiber Optics:** 800°F (427°C) max. glass (for infrared).  
372°F (175°C) max. quartz (for ultraviolet).

**OPTICAL FIELD OF VIEW:** 13 sq. in. @ 3 feet (100 sq. cm. @ 1.0 meter)

**FIGURE 1. DIMENSIONS, SCANNER WITH FIBER OPTIC INNER AND OUTER CARRIERS**

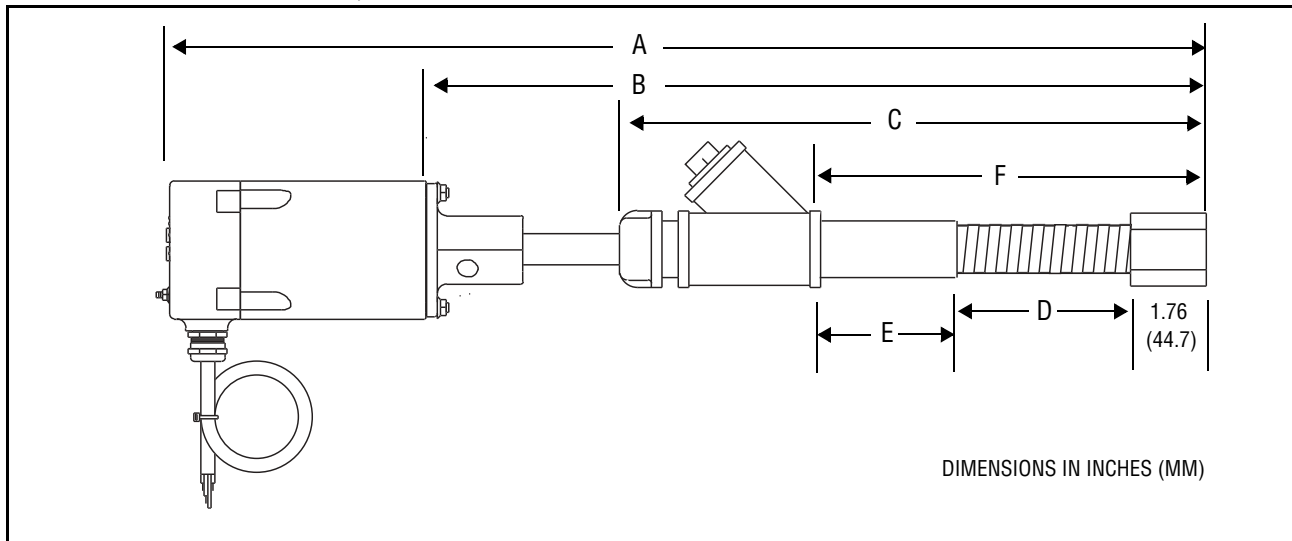

NOMINAL LENGTH *	A	B	C	D	E	F
FEET	INCHES (MM)					
3	43.0 (1092)	36.0 (914)	24.0 (610)	9.0(229)	7.7 (196)	18.5 (470)
5	68.5 (1740)	61.5 (1562)	49.0 (1245)	38.0 (965)	3.8 (97)	43.6 (1107)
6	79.5 (2019)	72.5 (1842)	60.0 (1524)	38.0 (965)	15.0 (381)	54.8 (1392)
7	96.5 (2451)	89.5 (2273)	77.0 (1956)	38.0 (965)	32.0 (813)	71.8 (1824)
9	115.0 (2921)	108.0 (2743)	96.0 (2438)	48.0 (1219)	41.0 (1041)	90.8 (2306)
10	127.0 (3226)	120.0 (3048)	108.0 (2743)	60.0 (1524)	41.0 (1041)	102.8 (2611)
12	151.0 (3835)	144.0 (3658)	132.0 (3353)	84.0 (2134)	41.0 (1041)	126.8 (3221)
14	175.0 (4445)	168.0 (4267)	156.0 (3962)	108.0 (2743)	41.0 (1041)	150.8 (3830)
17	217.0 (5512)	210.0 (5334)	196.8 (4999)	149.2 (3790)	40.8 (1036)	191.6 (4867)

\*Note: The "Nominal Length" refers to the approximate length of the overall assembly, including the installed electronics. Refer to dimensions "A" through "F" to determine the nominal length that best suits your application.

**FIGURE 2. OUTER CARRIER ASSEMBLY**

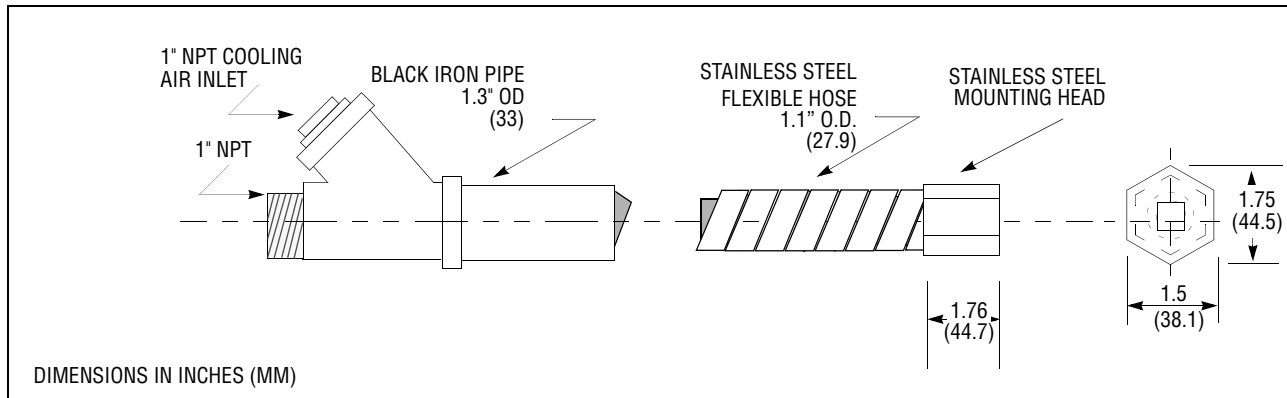

**FIGURE 3. INNER CARRIER ASSEMBLY**

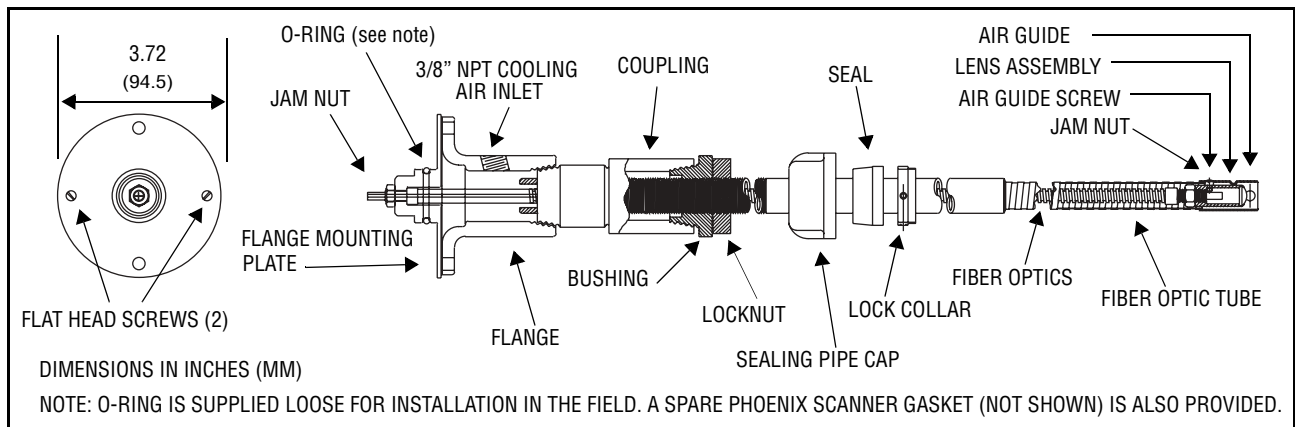

## ORDERING INFORMATION

The fiber optic scanner assemblies consist of three part numbers which must be ordered separately as described below.

1. Select the appropriate PHOENIX SCANNER assembly for your application.
2. Referring to Figure 1, determine the fiber optic assembly nominal length that suits your application.
3. Select the OUTER CARRIER assembly with the proper nominal length.
4. Select the INNER CARRIER assembly, (which includes the fiber optics and lenses), with the proper nominal length. **Quartz optics are required for 85UVF ultraviolet scanners. Glass optics are recommended for 85IRF infrared scanners.**

Example: To order a fiber optic 85IR Phoenix scanner assembly with 4 second flame failure response time (FFRT) and with a nominal 9 ft. length, order:

- Item 1. P/N 85IRF4-2 Phoenix Scanner assembly
- Item 2. P/N 61-5386 Outer carrier assembly
- Item 3. P/N 61-7065-9 Inner carrier assembly, with glass optics



## ORDERING INFORMATION (continued)

PHOENIX SCANNER PART NUMBERS				
FFRT	Infrared	Infrared, Class 1, Div. 2	Ultraviolet	Ultraviolet, Class 1, Div. 2
1 Second	85IRF1-2	85IRF1-2EX	85UVF1-2	85UVF1-2EX
2 Seconds	85IRF2-2	85IRF2-2EX	85UVF2-2	85UVF2-2EX
3 Seconds	85IRF3-2	85IRF3-2EX	85UVF3-2	85UVF3-2EX
4 Seconds	85IRF4-2	85IRF4-2EX	85UVF4-2	85UVF4-2EX

OUTER CARRIER ASSEMBLY (use with Glass or Quartz)		(GLASS) INNER CARRIER ASSEMBLY	(QUARTZ) INNER CARRIER ASSEMBLY
NOMINAL LENGTH* feet (meters)	PART NUMBER	PART NUMBER	PART NUMBER
3 (0.9)	61-6647	61-7065-3	61-7064-3
5 (1.5)	61-5430	61-7065-5	61-7064-5
6 (1.8)	61-6845	61-7065-6	61-7064-6
7 (2.1)	61-4893	61-7065-7	61-7064-7
9 (2.7)	61-5386	61-7065-9	61-7064-9
10 (3.0)	61-6305	61-7065-10	61-7064-10
12 (3.7)	61-6306	61-7065-12	61-7064-12
14 (4.3)	61-6540	61-7065-14	61-7064-14
17 (5.2)	61-6951	61-7065-17	—

REPLACEMENT PARTS		
FIBER OPTIC BUNDLE	GLASS BUNDLE	QUARTZ BUNDLE
NOMINAL LENGTH * feet (meters)	PART NUMBER	PART NUMBER
3 (0.9)	61-4842-7	61-6872-3
5 (1.5)	61-4842-3	61-6872-5
6 (1.8)	61-4842-9	61-6872-6
7 (2.1)	61-4842-1	61-6872-7
9 (2.7)	61-4842-2	61-6872-9
10 (3.0)	61-4842-4	61-6872-10
12 (3.7)	61-4842-5	61-6872-12
14 (4.3)	61-4842-6	61-6872-14
17 (5.2)	61-4842-11	—
LENS ASSEMBLY	WITH GLASS LENS	WITH QUARTZ LENS
LENS SKEW	PART NUMBER	PART NUMBER
0 deg. skew	61-4895 ("TA")	61-6754 ("AA")
5 deg. skew	61-4913 ("TB")	61-6864 ("AB")
9 deg. skew	61-4914 ("TC")	61-6865 ("AC")

*\*Note: The "Nominal Length" refers to the approximate length of the overall assembly, including the installed electronics. Refer to dimensions "A" through "F" to determine the nominal length that best suits your application.*

**FIGURE 4. PREFERRED LOCATION OF FIBER OPTIC ASSEMBLY**

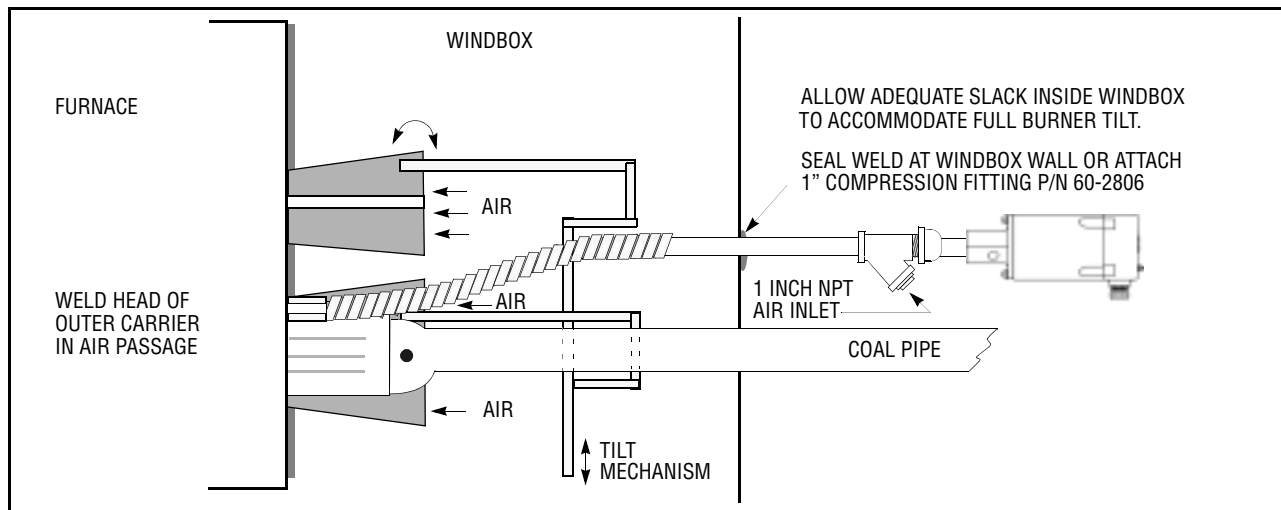

**FIGURE 5. ALTERNATE LOCATION OF FIBER OPTIC ASSEMBLY**

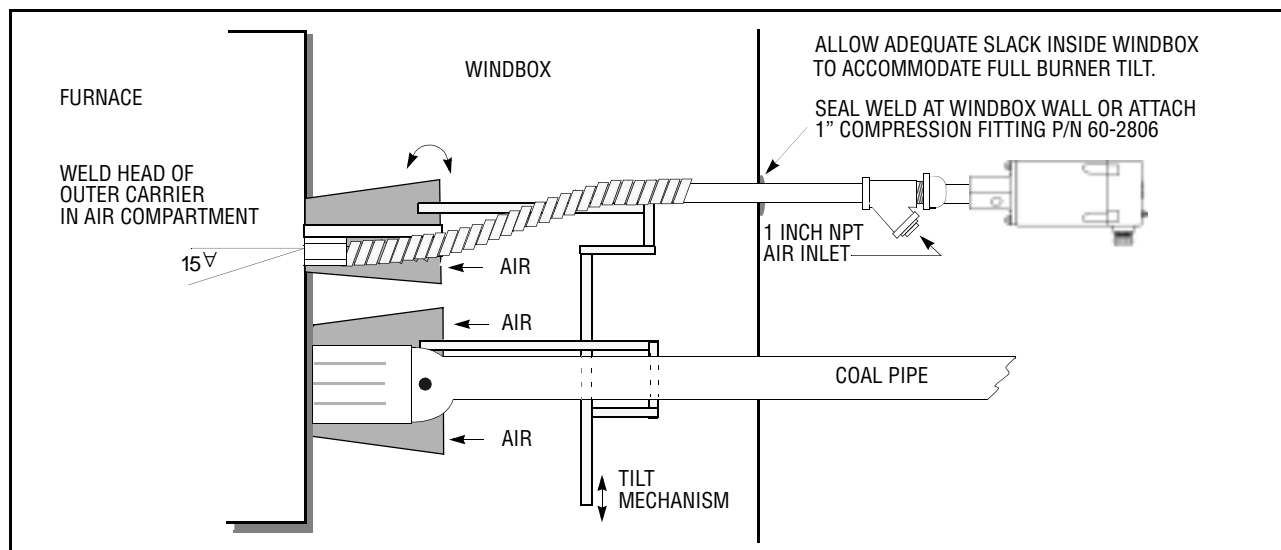

## INSTALLATION AND MOUNTING

### OUTER CARRIER

The outer carrier assembly, Figure 2, contains the 1" NPT cooling air "Y," a rigid-to-flexible 1" pipe assembly which terminates with a rugged hexagonal mounting head. The mounting head shall be tack welded within the windbox-furnace area, (welding should be performed with the inner carrier removed). For best results, the mounting head should be welded into an air passage, parallel with, and as close as possible to, the fuel delivery nozzle. If it is not practical to attach the head inside an airway of a fuel compartment, (Fig. 4), it may be attached to the nearest air compartment, (Fig. 5). Leave adequate slack in the flexible carrier tube to allow for vertical motion of the compartments. Avoid sharp or multiple bends to allow for insertion and removal of inner carrier. Pass the rigid pipe portion of the outer carrier through the windbox wall, and after cycling the burner through its range of motion, weld it firmly in place, sealing the windbox air within. Alternately, you may use 1" compression fitting, P/N 60-2806.

*Note: The flexible portion of the outer carrier may have been stretched or compressed during shipment. Prior to final installation, restore flexible section length to dimension "D" in Figure 1.*



### **INNER CARRIER** (Refer to Figures 1 and 3)

Install the O-ring on the flange mounting plate.

The inner carrier assembly contains the mating flange for the scanner electronics, the 3/8" NPT cooling air connection, the fiber optic bundle, and the objective lens assembly. The lens assembly provides a fixed degree of skew to its optical axis. As shipped, a straight zero degree skew lens assembly, (marked "A"), is installed. This should provide satisfactory results in many applications. If, due to mounting irregularities, insufficient flame signal results, the 5 degree, (marked "B"), or 9 degree, (marked "C"), skewed lens assemblies, (provided), may be installed, as described below. Prior to installing the inner carrier assembly into the outer carrier, loosen the inner carrier lock collar set screws, which will allow the collar to slide freely along the inner carrier tube.

When final lens and orientation are selected, slide the inner carrier lock collar down to the outer carrier pipe and lock it in place with two hex socket set screws. Finally, secure the inner carrier assembly to the outer carrier, by tightening the 1" sealing pipe cap.

### **CHANGING LENS ASSEMBLY** (Refer to Figures 1 and 3)

The following describes the procedure required to replace a damaged lens assembly, or to install a lens of a different skew.

*Note: To avoid damage to the fiber optic bundle when applied to a tilting bucket style burner, the bucket must be in the position that results in the carrier assembly being as straight as possible when removing and replacing the inner carrier assembly.*

1. Disconnect the scanner cooling air from the 3/8" connection.
2. Remove the Phoenix scanner from the inner carrier assembly by removing the two 7/16" nuts.

*Note: A moderate amount of force will be required to break the o-ring seal.*

3. Disconnect the inner carrier from the outer carrier by loosening the 1" sealing pipe cap, and carefully remove the inner carrier.
4. Lay the carrier assembly on a flat work surface and straighten, applying no more than 30 lbs. tension.
5. Remove the single pan head screw from the air guide head.
6. Remove the two flat head screws holding the flange mounting plate to the housing flange, and carefully retract the flange mounting plate, fiber optics, and lens assembly clear of the housing flange.
7. Loosen the jam nut behind the lens assembly. Unscrew and remove old lens assembly.
8. Install new lens assembly. Project light onto the fiber adapter end of the fiber optics. Looking into the lens, rotate lens assembly until a clear image of the fiber optic strands is visible. The image should fill from 70% to 100% of the lens when viewed from a distance of 6" to 12." Replace the fiber optic bundle if more than 50% of the fibers appear dark. Tighten the jam nut at the lens assembly.
9. Straighten the inner carrier by applying 30 lbs. tension. Lay the inner carrier assembly straight, with the air guide screw hole facing up. Insert the fiber optics and lens assembly into the inner carrier. Line up the lens assembly and air guide holes, and replace the pan head screw.
10. With the inner carrier straightened as described, the maximum distance between the flange mounting plate, (with attached fiber optics), and the mounting flange, should be between 1/2" - 1" (12.7 - 25.4mm). Greater distances may result in damaged fibers when attaching the flange mounting plate. This distance may be adjusted by loosening the locknut from the mounting flange coupling and rotating the flange and coupling on the 1/2" pipe, then securely tightening the locknut. Align the holes of the flange mounting plate, gasket, and housing flange, and install the two flat head screws.
11. Install the inner carrier into the outer carrier, and tighten the 1" sealing pipe cap.
12. Install the scanner electronics on the inner carrier.
13. Reconnect the scanner cooling air.

### ADJUSTING SKEWED LENS ORIENTATION (Refer to Figures 1 and 3)

The following describes the procedure required to “aim” the skewed lens assembly to obtain the best flame signal response. Refer to the Fireye bulletin CU-105.

*Note: To avoid damage to the fiber optic bundle when applied to a tilting bucket style burner, the bucket must be in the position that results in the carrier assembly being as straight as possible when removing and replacing the inner carrier assembly.*

1. Install the skewed lens assembly as outlined under “CHANGING LENS ASSEMBLY.”
2. With the inner carrier and scanner electronics installed and the burner firing, record the flame signal response.
3. Remove the inner carrier assembly, noting its position relative to the outer carrier. The external screw on the air guide outside the lens may be used to index and record the orientation. Smooth out any kinks in the flexible section. Rotate the inner carrier to a new orientation and re-insert. Record the new flame signal response. Continue to remove and re-insert, rotating the carrier 90 degrees each time until maximum flame response is obtained.
4. Secure the inner carrier by tightening the 1" sealing pipe cap.
5. Reconnect the scanner cooling air.

### REPLACING FIBER OPTIC BUNDLE (Refer to Figures 1 and 3) (See WARNING)

The following describes the procedure required to replace the fiber optic bundle.

*Note: To avoid damage to the fiber optic bundle when applied to a tilting bucket style burner, the bucket must be in the position that results in the carrier assembly being as straight as possible when removing and replacing the inner carrier assembly.*

1. Remove the inner carrier assembly, and fiber optic assembly by following steps 1 through 6 listed under “CHANGING LENS ASSEMBLY” section.
2. Loosen jam nut behind lens assembly, then unscrew and remove lens assembly and jam nut.
3. Remove jam nut at flange mounting plate, and unthread the flange mounting plate.
4. Thread the flange mounting plate onto the new fiber optic until it seats. Install jam nut and tighten to 3-4 inch pounds.
5. Install jam nut (flat side facing out) and lens assembly. Project light onto the adapter end of the fiber optics. Looking into the lens, rotate lens assembly until a clear image of the fiber optic strands is visible. The image should fill from 70% to 100% of the lens when viewed from a distance of 6" to 12." Tighten the jam nut at the lens assembly.
6. Straighten the inner carrier by applying 30 lbs. tension. Lay the inner carrier assembly straight, with the air guide screw hole facing up. Insert the fiber optics and lens assembly into the inner carrier. Line up the lens assembly and air guide holes, and replace the pan head screw.
7. With the inner carrier straightened as described, the maximum distance between the flange mounting plate, (with attached fiber optics), and the mounting flange, should be between 1/2" - 1" (12.7 - 25.4mm). Greater distances may result in damaged fibers when attaching the flange mounting plate. This distance may be adjusted by loosening the locknut from the mounting flange coupling and rotating the flange and coupling on the 1/2" pipe, then securely tightening the locknut. Align the holes of the flange mounting plate, gasket, and housing flange, and install the two flat head screws.
8. Install the inner carrier into the outer carrier, and tighten the 1" sealing pipe cap.
9. Install the scanner electronics on the inner carrier.
10. Reconnect the scanner cooling air.



**WARNING: Fiber optic bundles are FRAGILE! Do not apply excessive compression or tension force. Do not “coil” bundles tighter than a 10" loop.**

## ACCESSORIES

### P/N 60-2806 1" Compression Fitting

The 60-2806 Compression Fitting slides over the Fireeye fiber optic outer carrier assembly and is used to attach the outer carrier to the burner front. It is comprised of a flange that is welded or bolted to the burner, and a compression nut that is tightened to secure the outer carrier.

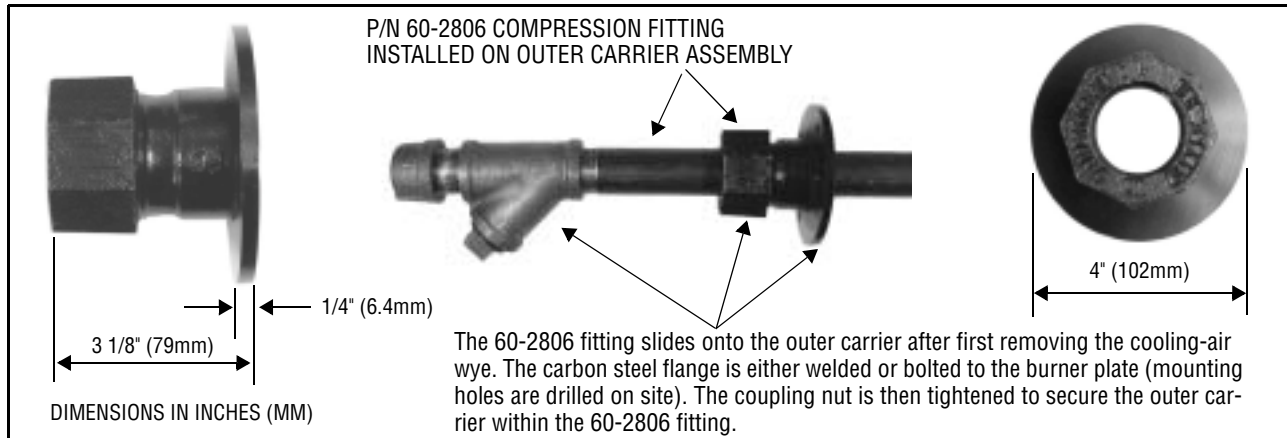

## NOTICE

When Fireeye products are combined with equipment manufactured by others and/or integrated into systems designed or manufactured by others, the Fireeye warranty, as stated in its General Terms and Conditions of Sale, pertains only to the Fireeye products and not to any other equipment or to the combined system or its overall performance.

## WARRANTIES

FIREYE guarantees for *one year from the date of installation or 18 months from date of manufacture* of its products to replace, or, at its option, to repair any product or part thereof (except lamps, electronic tubes and photocells) which is found defective in material or workmanship or which otherwise fails to conform to the description of the product on the face of its sales order. **THE FOREGOING IS IN LIEU OF ALL OTHER WARRANTIES AND FIREYE MAKES NO WARRANTY OF MERCHANTABILITY OR ANY OTHER WARRANTY, EXPRESS OR IMPLIED.** Except as specifically stated in these general terms and conditions of sale, remedies with respect to any product or part number manufactured or sold by Fireeye shall be limited exclusively to the right to replacement or repair as above provided. In no event shall Fireeye be liable for consequential or special damages of any nature that may arise in connection with such product or part.



FIREYE™  
3 Manchester Road  
Derry, New Hampshire 03038 USA

CU-106  
SEPTEMBER 14, 2005  
Supersedes Oct. 2004

