

FIREYE® CA202 ACTUATOR

DESCRIPTION

A part of the Fireye FOCUS Combustion Efficiency System¹, the CA202 trim Actuator is a stepper motor which positions the burner's air damper in response to pulse inputs from the AM200 actuator module. The CA202 Trim actuator receives the pulses via the pre-fabricated cable (P/N CA59-XXX).

The CA202 trim actuator is mounted in the linkage rod between the driving member and driven linkage of the burner's air inlet damper.

FIGURE 1. Typical Location for Trim Actuator

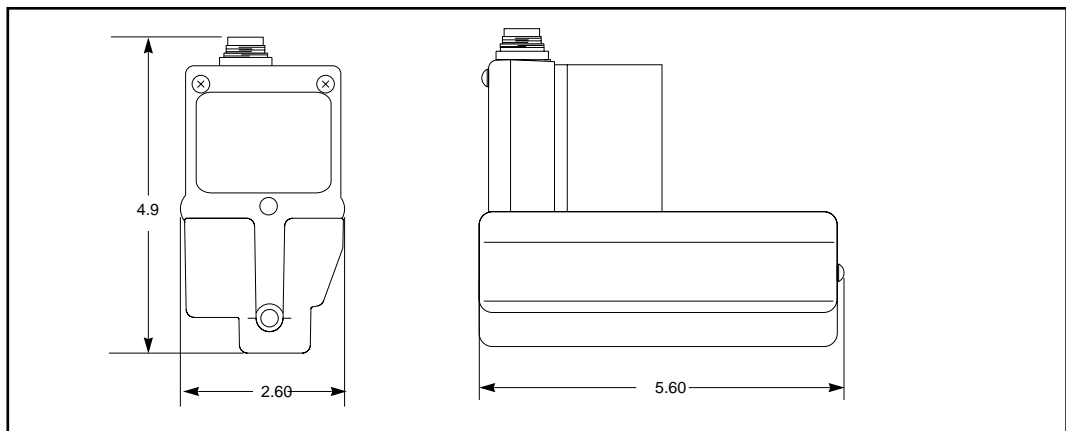

The CA202 Trim Actuator is installed in the linkage rod via the following steps:

1. Locate area to mount actuator. CHECK for interferences and fit.
2. Remove the linkage rod between the air damper's driving linkage arm and the driven arm. The CA202 will accept 5/16" linkage rod. Linkage rods other than 5/16" will require modification to make them fit the 5/16" fitting in the actuator.
3. Remove the covers from the actuator. The cover is held in place by two screws.
4. Cut the linkage rod and attach each end to the actuator using provided rod clamps and set screws. DO NOT OVER TORQUE (set screw torque is 50-70 in-lbs.).

¹. Patent Pending

5. Mount D-shape felt washer overl linkage rod (on gear case housing end) with radius side facing down.
6. Remount covers on actuator. Mount round steel wash and then round felt washer before attaching dust cover with screws.
7. Re-install linkage rod/actuator assembly.
8. Connect pre-wired CA59-XXX cable to the actuator. Before securing the cable, insure that there is adequate cable for full motor movement over the operating range of the damper assembly.

SPECIFICATIONS

Shipping Weight:	2 lbs.
Mounting Position:	Any
Interface:	5/16" rod
Travel:	2.0"
Maximum Shift Time:	2.0" / 12seconds
Force:	40 lbs. max. moving, 200 lbs. max. holding.
Wiring:	Pre-fabricated cables directly connected to controller.
Operating Temperature:	32° F (0° C) to 149° F (60° C).
Storage Temperature:	-40° F (-40° C) to 194° F (90° C).
Humidity:	85% non-condensing.

FIGURE 2. FOCUS ACTUATOR CA202 SIDE VIEW WITHOUT COVER (shown in fully extended position)

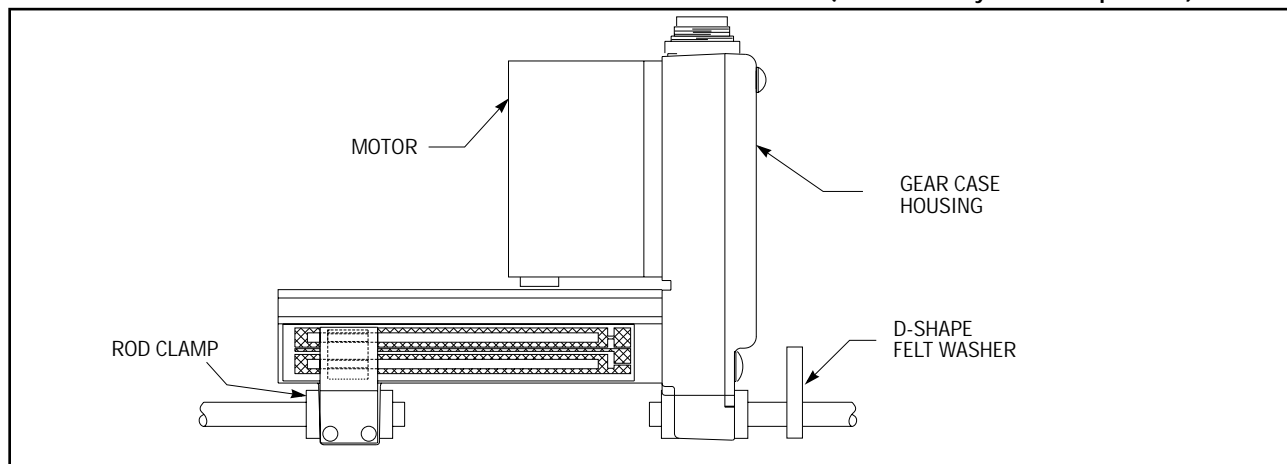

The CA202 trim actuator is mounted in the linkage rod between the driving member and driven member, of the burner's air inlet damper.

HARDWARE BAG

The following items are shipped in a hardware bag along with the CA202 Actuator:

PART NUMBER	DESCRIPTION	QUANTITY
13-375	Rod Clamp	2
48-1890	Set Screw 1/4 - 20 x 3/8 LG	2
49-544	Round Felt Washer	1
49-545	D-Shape Felt Washer	1
49-546	Round Steel Washer	1